

Max Compact Interior Technical Manual

North America Edition | March 2025



For you to create



www.fundermax.us

Fundermax

**“Contemporary technology,
timeless design – that’s what
we want to be surrounded by.”**

(Stephan R., carpenter)





Contents

Products	4
Sustainability and the Environment	10
Material	14
Processing recommendations	18
Chemical resistance	36
Cleaning	44
Wall cladding	46
Cubicles	54
Soffits and ceilings	64
Table tops	68
Furniture	72
Worktops	76
Wash basins	86
Railings	90
Suppliers/accessories	97

Note:

Current version of this brochure:
www.fundermax.com

The diagrams in this brochure are schematic representations and not true to scale.

This issue replaces all previously published issues of the Technique Interior Brochure by Fundermax.

If you have any questions that this brochure does not answer, please contact our sales team or application engineers at support@fundermax.biz. We will be happy to help you.

Fundermax

No matter whether it's furniture, facades, or interior design: where ideas and materials meet, you'll find Fundermax. As a global market leader in the field of compact panels and a manufacturer of high-quality wood-based materials and laminates, the company is proud to look back on a history spanning 130 years. The continued success is based on the highest quality, innovative and varied design, and sustainable production. Made in Austria—with great love for wood as a natural material, creations, and imagination.

- modern production facilities in Austria and Norway
- around 1,500 employees
- annual sales of €500 million
- part of Constantia Industries AG
- The Austrian Excellence Award (2018)

1 Products

“Only good ideas and good products are really durable.”

(Isabelle S., Project Manager)





Max Compact Interior

These are thermoset high-pressure laminates (HPL) that meet the requirements of EN 438 and are produced at high temperature and under great pressure. The product variants are as diverse as the applications: The panels are suitable not only for use in sanitary and wet rooms, but also as wall and column cladding, as railing fillings, as furniture, tables, desks and laboratory furniture. Whenever both resilience and aesthetics are required, HPL panels are an excellent material to use.

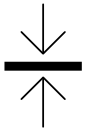

resistant



impact-resistant



scratch resistant



quick installation



solvent resistant



food grade



easy to clean



heat resistant

Properties*

- hygienic
- bending resistant and impact resistant (according to EN ISO 178)
- suitable for all indoor applications
- decorative
- resistant to scoring
- abrasion resistant
- frost and heat resistant
- continuous temperature load -80 °C to $+80\text{ °C}$
- easy to install
- resistant to chemicals

* Standard and actual values: www.fundermax.com

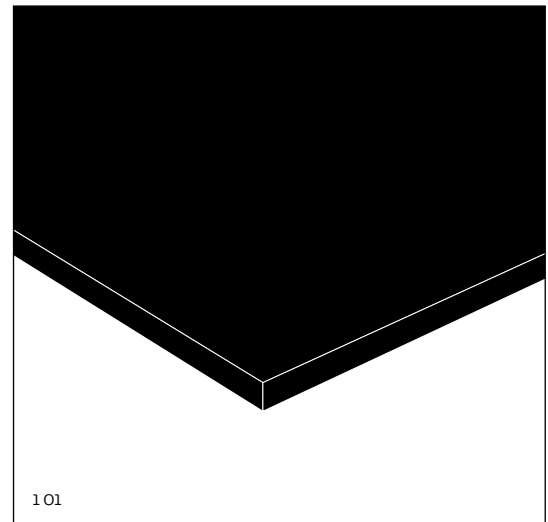

Formats*

The overview shows Max Compact Interior panel formats in various product designs.

* Subject to change due to product development. Please refer to the valid product portfolio.

Tolerances: +10.0–0.0 mm (EN 438–4, 6.3)

Panel formats are standard sizes—if absolute size and angle precision is required, it is recommended to cut around all sides. Depending on the cut, the net measurement reduces by about 10 mm.

Thickness	Tolerance (EN 438–6, 5.3)
• 2.0–2.9 mm	±0.2 mm
• 3.0–4.9 mm	±0.3 mm
• 5.0–7.9 mm	±0.4 mm
• 8.0–11.9 mm	±0.5 mm
• 12.0–15.9 mm	±0.6 mm
• 16.0–19.9 mm	±0.7 mm
• 20–25 mm	±0.8 mm

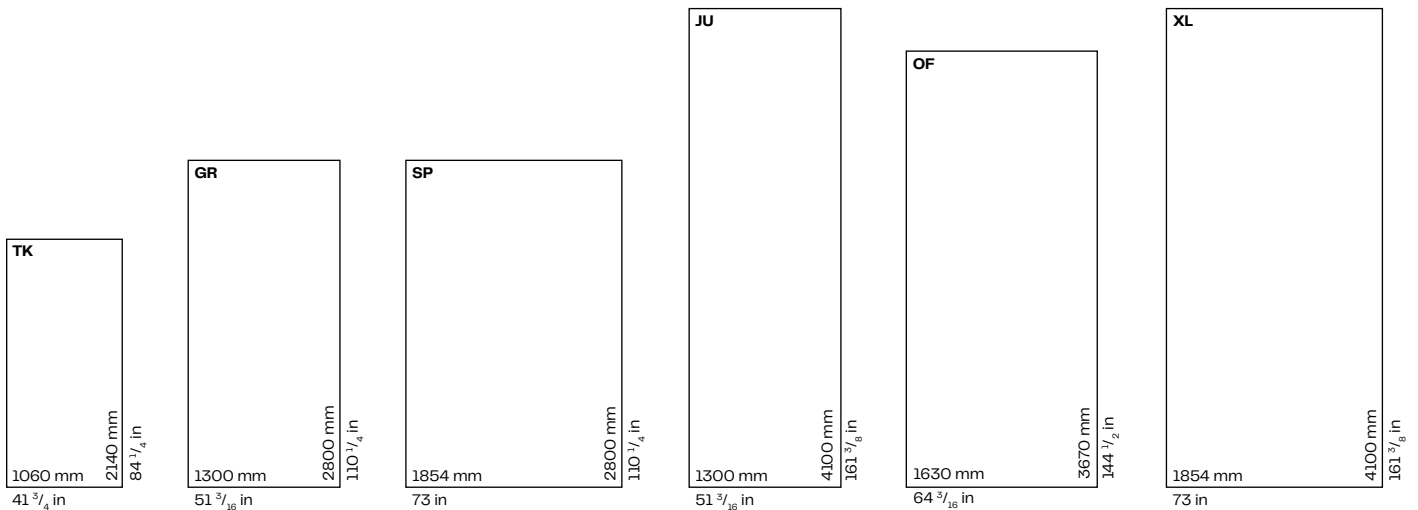

To see the current range of format sizes for each product: fundermax.us/product/interior-architectural-panels/

Product selection

Max Compact Interior

Max Compact panels come with decorative laminate on both sides as standard. The core is black and the surfaces are available in various structures (see current product portfolio).

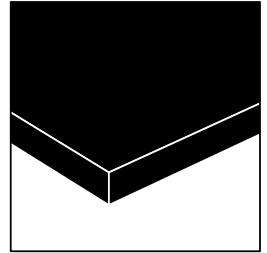

Max Compact Interior Plus

These panels have the same qualities as the Max Compact Interior panels, but are manufactured with a double-hardened, non-porous surface sealed with urethane acrylate for increased surface protection (decors: see decor collection IP).

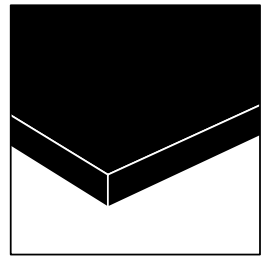

Max Resistance²

Max Compact Interior panels with integrated, chemical-resistant surface (decors: see decor collections Resistance² RE).

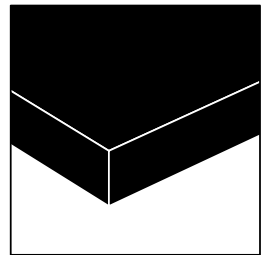

Max Compact with white/ solid colored core

Panel core white or solid color. There can be a slight color difference between the laminate and the Compact panel with a white or solid colored core. If these are to be combined please compare samples! Same decors on both sides. Decors and surfaces according to the valid product portfolio.

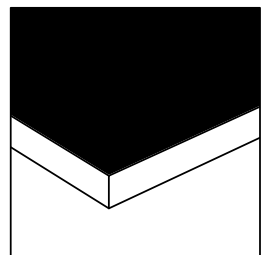

Alu Compact

Max Compact Interior panels with aluminum strips symmetrically inserted in the core. This makes the panels a modern design element.

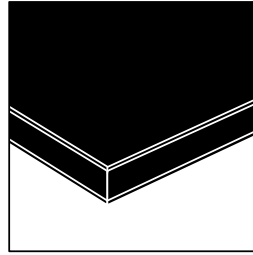

Fundermax elements (processing)

CNC controlled processing and panel cutting – from drilling simple holes to intricate milling.

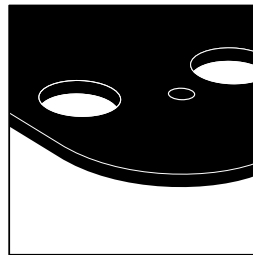

2 Sustainability and the Environment

“I want my work to leave a mark – but it should be sustainable.”

(Henrik T., entrepreneur)





Fundermax has been a specialist in the processing of renewable raw materials for over 100 years. We have closed production cycles and recycle residues by returning them to the manufacturing process or to green power district heating plants. The latter produce enough electricity to supply over 8,500 households.





Quality management

Production facilities and processes comply with internationally recognized standards (ISO 9001, ISO 14001, ISO 50001, ISO 45001).

Fundermax is also guided by current standards such as FSC®-C101966 and PEFC™ in the procurement of raw materials and intermediate products (for details see www.Fundermax.com).

Sustainable production

Natural fiber panels comprise approximately 65% of the total weight of Max Compact Interior panels; they are made primarily from wood that is processed into 'kraft papers'. This wood is a by-product of sawn lumber production or sawmills. We source these raw materials from vendors certified to FSC®-C101966 and PEFC™ standards, which guarantee sustainable forestry.

Max Compact Interior, Interior Plus, and Max Resistance² contain up to 100% post consumer recycled content.*

Fundermax can potentially contribute to LEED in several categories with our EPD, HPD, FSC, and Greenguard Certificates.

The kraft papers are impregnated with synthetic resins in impregnation facilities, dried, and pressed into panels under high pressure and heat. They contain no organic halogen compounds, asbestos or wood protection agents (fungicides, pesticides, etc.), and are free of sulphur, mercury and cadmium.

The exhaust air removed in the drying process is treated using a process of regenerative thermal oxidation, with the resulting heat fed back into the drying process – thereby saving some 10,000 tons of carbon dioxide annually. In recognition of its exhaust air treatment, Fundermax received the 'klimaaktiv' award from the Austria Energy Agency and the Austrian Federal Ministry of the Environment.

Long-lasting and maintenance-free

Thanks to the manufacturing process, Max Compact Interior panels are guaranteed a long lifespan and a highly resistant surface – with no need for maintenance at all. Although the panels do not soil easily, they can be cleaned with standard cleaning agents if necessary.

It is not necessary to seal the edges, even after cutting. Even under severe pressure (for example, where used for impact protection), there are no impact marks.

Disposal

The chips produced in the cutting and milling of Max Compact Interior panels can be thermally disposed of in modern heating plants without creating hydrochloric acid, organic chlorine compounds or dioxins. Max Compact Interior simply breaks down into carbon dioxide, nitrogen, water and ash. The energy accrued is used for district heating, among other things. Disposal via industrial landfill is also unproblematic and carried out in line with national laws and regulations.

* Fundermax F-Quality products do not use recycled paper in the core.

3 Material





“The material is instrumental in determining whether an idea remains just an idea.”

(Hannes K., architect)

Material properties

	Max Compact Interior Max Compact Interior Plus Max Resistance ²	Max Compact Interior F-Quality Max Compact Interior Plus F-Quality	Max Compact with white / colored core	Max Compact Interior Alu Compact
Type according to EN 438	CGS	CGF	BCS	RCS
Properties	Test method	Standard value ¹⁾	Typical value ²⁾	Unit of measurement
Physical data				
Bulk density	DIN 52350 ISO 1183	≥ 1.35 (CGS/CGF/RCS) ≥ 1.40 (BCS)	≥ 1.44 (CGS/CGF) 1.46 (BCS) 1.52 (RCS)	g/cm ³
Weight (thickness 10 mm)			3	lbs/ft ²
Mechanical properties				
Resistance against stress abrasion (initial point)	EN 438-2: 2016, 10	≥ 150 (BCS/CGS/CGF/RCS)	200 Resistance ² / Surface Aptico Uni: ≥ 450 Resistance ² Punto: ≥ 150	U
Resistance to impact with a large ball	EN 438-2: 2016, 21	≤ 10 (CGS/CGF/RCS)	5-6 (CGS/CGF/RCS)	mm
Scratch-resistance	EN 438-2: 2016, 25	≥ 3 (BCS/CGS/CGF/RCS)	4 (BCS/CGS/CGF/RCS)	Degree/ scratch hardness
Flexural strength	EN ISO 178	≥ 80 (BCS/CGS/CGF/RCS)	crosswise: 110 / length: 180	MPa
E-Modulus	EN ISO 178	≥ 9000 (BCS/CGS/CGF/RCS)	crosswise: 11000 / length: 15000	MPa
Susceptibility to cracking	EN 438-2: 2016, 24	≥ 4 (CGS/CGF/RCS) ≥ 4 (BCS surface) ≥ 3 (BCS core)	4 (CGS/CGF/RCS) 5 (BCS surface) 3 (BCS core)	Degree
Thermal properties				
Dimensional tolerance at high temperature	EN 438-2: 2016, 17	Type CGS/CGF/RCS: ≤ 0.30 lengthwise / ≤ 0.60 crosswise Type BCS: ≤ 0.50 lengthwise / ≤ 0.80 crosswise	Type CGS/RCS: 0.10 lengthwise / 0.21 crosswise Type CGF: 0.08 lengthwise / 0.16 crosswise Type BCS: 0.20 lengthwise / 0.33 crosswise	%
Resistance to dipping in boiling water	EN 438-2: 2016, 12	Thickness increase ≤ 2.0 (CGS/RCS) / ≤ 6.0 (CGF) ≤ 4.0 (BCS)	0.5 (CGS/CGF/RCS) 1.5 (BCS)	%
Coefficient of thermal expansion	EN 61340-4-1		20 x 10 ⁻⁶	1/K
Thermal conductivity			approx. 0.3	W/mK
Resistance to vapor diffusion			17200 μ (CGS/CGF) vapor diffusion density (RCS)	
Surface resistance	DIN 53482		10 ⁹ -10 ¹²	Ohm
Resistance to dry heat	EN 438-2: 2016, 16	≥ 4 (BCS/CGS/CGF/RCS)	4 (BCS/CGS/CGF/RCS)	Degree
Resistance to humid heat	EN 438-2: 2016, 18	≥ 4 (CGS/CGF/RCS)	4-5 (CGS/CGF/RCS)	Degree
Resistance to water vapor	EN 438-2: 2016, 14	≥ 4 (BCS/CGS/CGF/RCS)	5 (BCS/CGS/CGF/RCS)	Degree
Chemical resistance	Max Resistance² Max Compact Interior Plus		Max Compact Interior Max Compact Interior Plus	
SEFA	SEFA 3		SEFA 8	
Optical properties				
Light fastness	EN 438-2: 2016, 27	4-5 (CGS/CGF) ≥ 4 (BCS surface)	4-5	Gray scale
Stain resistance	EN 438-2: 2016, 26	≥ 4 (Group 1 and 2) 5 (Group 3)	5	Degree
Gloss level at 85°	EN ISO 2813	depending on the surface structure	Aptico surface: 7 Other surfaces: depending on the surface structure	GE
Fire test data				
Max Compact Interior				Class A Rated Per ASTM E84 (13mm thick and greater)
Max Compact Interior F-Quality				Class A Rated Per ASTM E84
Max Compact Interior Plus				Class A Rated Per ASTM E84 (13mm thick and greater)
Max Compact Interior Plus F-Quality				Class A Rated Per ASTM E84
Max Resistance ²				Class A Rated Per ASTM E84 (13mm thick and greater)
Max Compact Interior Color Through Core				Class B rated Per ASTM E84, (25mm thick ,Class A, <25mm Class B)

1) according to EN 438

2) Typical values result from internal quality checks. They are presented exclusively as examples and cannot be used for any liability on the part of Fundermax (they are not confirmed, guaranteed values).

EN 438 Compact Laminate Classification:

RCS - Metal reinforced core layer standard grade compact laminate
CGF - Compact laminates with improved fire retardance

BCS - Standard grade Coloured core layer compact laminate
CGS - Standard grade compact laminates

Material characteristics

Material quality

3 01 Dimensional change with moisture release or absorption

Material characteristics and expansion clearance

Max Compact panels react to temperature and humidity, according to the climactic conditions of the respective storage and mounting area. If both of these influential factors affect one side of the panel only for a longer period of time, it can lead to variations of flatness to a greater or lesser extent. Please take note of our advice concerning rear ventilation, storage and stack coverage!

Max Compact shrinks when moisture is released and expands when moisture is absorbed. Therefore, thought must be given to this possible dimensional change when working and constructing. For Max Compact it is basically about half as much lengthwise (relative to the nominal panel formats) as in the width (see Material properties, page 16).

Metal substructures change their dimension with temperature differences. However, Max Compact dimensions also change under the influence of increasing relative humidity. These dimensional changes of the substructure and cladding material can work in opposing directions. Therefore, it is important to ensure sufficient room for expansion.

For Max Compact panel type CGS and CGF, OFI CERT as a global authorization body confirms the compliance with the quality standards in accordance with EN 438.

Hygiene

The surfaces of Fundermax panels are distinguished by their easy cleaning, maintenance, disinfectability and harmlessness in contact with food.

Please take the validity of the respective test certificates into account. You can find the current certificates at www.fundermax.us/code-compliance-and-testing/

Please also take note of the valid standards, regulations and guidelines for possible applications of materials with regard to fire behavior and fall protection.

Max Compact Panels can also be used in horizontal applications. In daily use, highly textured or deep matte surfaces may show visual glossing due to mechanical stress (e.g. due to shifting objects around such as plates or glasses). This effect is stronger in combination with dark decors and is a material-typical aging. It does not represent a deviation from the standard.

Rule of thumb for the amount of expansion clearance needed:

Element length = a
Element width = b

$$\frac{a \text{ or } b \text{ (in mm)}}{500} = \text{expansion clearance}$$

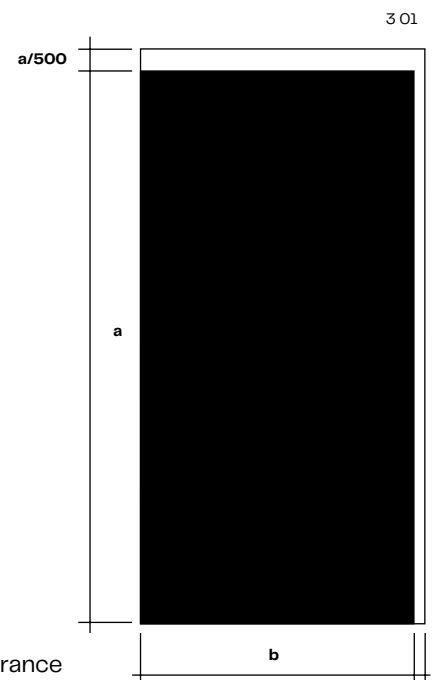

4 Processing recommendations





**“Good products call for
good treatment.”**

(Jonas G., contractor)

Guidelines for handling Max Compact Interior

Transport and manipulation

Handle with care! Despite surface hardness and transport protection film, the stack weight can cause damage. Therefore, it is important to avoid getting dirt or dust between the panels.

Secure the panels against slipping during transport and lift them during loading and unloading – do not pull or push them over the edge (see Fig. 4 01)!

Always remove transport protection films from both sides at the same time. Leaving the protection film on one side may cause curvature of the panel. To prevent surface damage: Do not remove the film until it is necessary. Increased adhesion of the film after storage may occur, requiring more force to remove it. This does not affect the quality of the product and is not a reason for complaint. Do not expose the film to direct sunlight or heat!

Storage and conditioning

Max Compact Interior panels must be left in their original packaging. They should be stacked horizontally on a flat, stable and padded surface. If necessary, they can be stored for a short time as shown in Fig. 4 03. The panels must lie completely flat. After removal, the original packaging should be closed again. Cover plates must always be left on the stack (see Fig. 4 02). The top cover should be weighted down. This also applies to cut-panel stacks.

Incorrect storage will cause permanent deformation of the panels.

Max Compact Interior panels should be stored indoors, under normal climatic conditions (15°C to 25°C, with relative humidity at 40-60%). Avoid climatic differences on the two surfaces.

In the case of preassembled fastening elements, make sure the climatic influence is the same from all sides. Use intermediate layers of wood or plastic (see Fig. 4 04).

To provide the finest quality material, assist in proper coordination of panel delivery and installation the following criteria have been established. It is imperative guidelines be met to minimize or eliminate the potential damage to panels prior to acceptance by the end user.

Installers should use these criteria to determine jobsite readiness during their pre-installation inspections.

1. The building areas requiring the installation of panels are to be dried-in and unexposed to any adverse weather conditions which may damage finished materials.
2. Interior building relative humidity must be between 40% and 60% at 60° to 80°F and EMC (Equilibrium Moisture Content) conditions between 8% and 12%.
3. Panels should be stored in the conditioned space in which they are going to be installed for a minimum of 72 hours prior installation.
4. Frequent or excessive changes in temperature or humidity levels during installation, or once panels are installed, must be avoided to prevent flatness issues.
5. All mechanical, electrical, or plumbing rough-in work required along walls and ceilings where panels are to be installed is to be completed prior to delivery of panels. Final connections are to be coordinated with wall panel installer. Painters must adequately protect the panels by covering and masking all surfaces prior to commencing. "Wet" operations to be performed by other trades must be completed prior to delivery.
6. Please see page 53 for special considerations when using systems with less than 3/4" airspace and reduced joint spacing.

Final cleaning

Foreign substances (e.g., drilling and machine oils, greases, adhesive residues, etc.) that soil the surface of the Max Compact Interior panels during storage, installation, and use, must be removed immediately without leaving any residue. We recommend using grease-free sunscreen (e.g., Physioderm Physio UV 50 Spray), since it is often not possible to remove conventional sunscreens completely. If these recommendations are not observed, we cannot accept responsibility for any complaints regarding color, gloss or surface. See Chapter 6, page 45 for cleaning details.

- 4 01 Max Compact Interior handling
- 4 02 Max Compact Interior stack storage
- 4 03 Short term temporary storage
- 4 04 Storage of pre-assembled elements

4 01

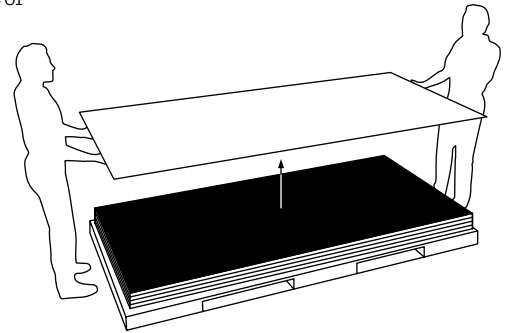

4 02

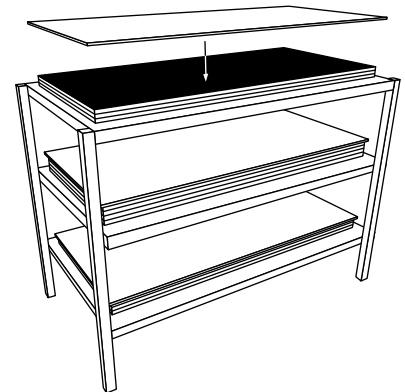

4 03

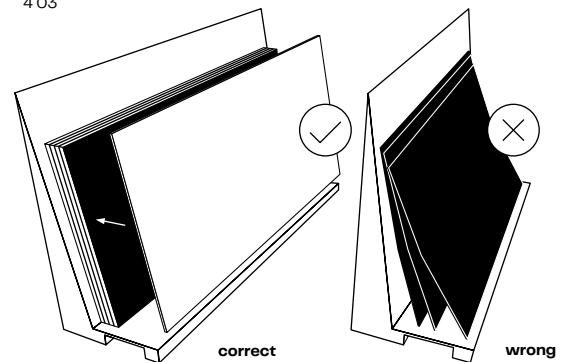

4 04

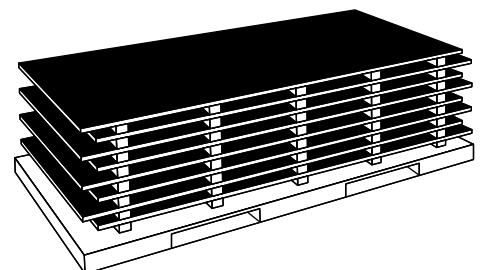

Working with Max Compact Interior

General

High-quality melamine resins make the panel surface very resistant. The processing properties are similar to those for the processing of hardwood. Tools with hard metal cutting edges are essential. Use tools equipped with diamond tips (PCD) for a long service life. To prevent chipping, splintering and flaking of the decorative side, sharp blades and smooth functioning of the tools are a must. To protect the surface and prevent chips from becoming lodged, machine tables should be smooth and as jointless as possible. This also applies to tables and using hand-held machines.

Safety measures

This is a list of the recommended personal protective equipment (PPE). The protective equipment required for the respective activity must be used (work clothes, safety boots, hairnets, etc.).



Gloves:

Non-beveled cutting edges are sharp. You should use gloves of protection category II with at least cut resistance 2.



Dust protection:

Processing these panels can create dust. Adequate respiratory protection (e.g., disposable fine dust mask) must be used.



Safety glasses:

When working with Max Compact Interior panels, as with other wood-based materials, use eye protection that is as tightly sealed as possible.



Hearing protection:

The sound level can rise above 80 dB(A) during mechanical processing. Please always make sure you have adequate hearing protection!

EN 388		Mechanical risks	
		The higher the number, the better the test result.	
4	1	2	1
Test criterion		Possible ratings	
Abrasion resistance		0-4	
Cut resistance		0-5	
Tear strength		0-4	
Puncture resistance		0-4	

General processing guidelines

Keep in mind the ratio between the number of teeth (z), cutting speed (v_c) and the feed rate (v_f).

	vc m/s	fz mm
Sawing	40.0-60.0	0.02-0.1
Milling	30.0-50.0	0.3-0.5
Drilling	0.5-2.0	0.1-0.6

Calculating the cutting speed

$$v_c = D \cdot \pi \cdot n / 60$$

v_c – cutting speed

D – tool diameter [m]

n – tool speed [min⁻¹]

Calculating the feed rate

$$v_f = f_z \cdot n \cdot z / 1000$$

v_f – feed rate [m/min]

f_z – tooth feed

n – tool speed [min⁻¹]

z – number of teeth

Cutting material

Use tools with hard metal cutting edges (HW-Leitz). In order to extend the life of your tools we recommend using diamond-tipped tools (DP polycrystalline diamonds).

Notes

If the chips are not regularly removed, this can quickly lead to damage of the blade. The required motor power is increased and the tool life is shortened. If the shavings are too small, they will scrape and eventually blunt the tool. For single cuts, prevent vibrations by working with used panels. Stack height depends on machine power.

Tooth forms

TR/TR (trapezoid tooth/trapezoid tooth):

For cutting hard, abrasive laminates

HZ/DZ (concave tooth/pointed tooth):

For very good cutting and edge quality at the top and at the bottom on machines without scoring unit

FZ/TR (flat tooth/trapezoid tooth):

For working with laminates and Max Compact Interior

WZ/FA (variable tooth with bevel):

Alternative to flat tooth/trapezoid tooth form

HZ/FA (concave tooth with bevel):

Use similar to HZ/DZ, but with longer tool life on machines without a scoring unit

- 4 05 TR/TR
- 4 06 HZ/DZ
- 4 07 Flat tooth/
trapezoid tooth
- 4 08 WZ/FA
- 4 09 HZ/FA

4 02

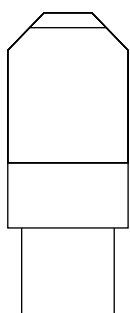

4 03

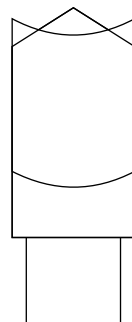

4 04



4 05



4 06

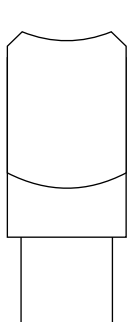

Cutting

4 07

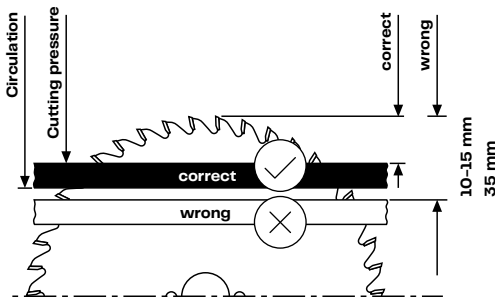

Vertical panel splitting, table and sliding table saws without scoring unit

For circular saw blades with positive rake angle and saw shaft under the workpiece. Due to the positive rake angle, the cutting pressure takes effect using the stable table support (see Fig. 4 10).

4 08

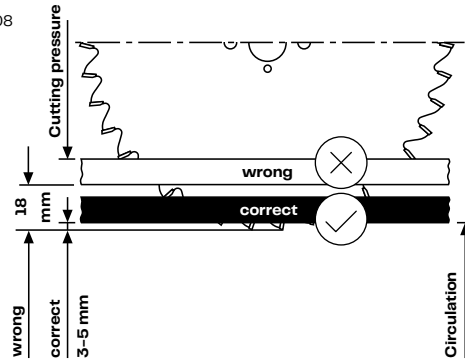

For circular saw blades with negative rake angle and saw shaft above the workpiece. Due to the negative rake angle, the cutting pressure takes effect using the stable table support (see Fig. 4 11).

Adjustment:

- visible side up;
- very narrow saw guide;
- smooth alignment of the Max Compact Interior panels on the workbench with the saw blade;
- correct blade protrusion.

Depending on the blade protrusion, the entry and exit angles will change and thus the quality of the cutting edge. Upper cutting edge unclear: raise the saw blade. Unclean cut on the bottom: lower the saw blade. This is how you find the most favorable height setting.

4 09

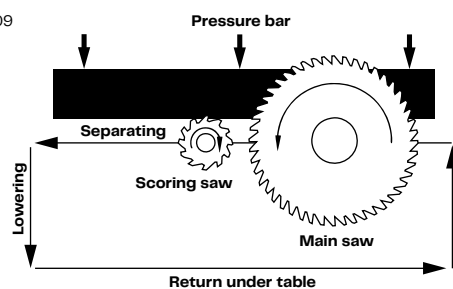

Sliding table saws and panel splitting machines with scoring units and pressure bars

Scoring circular saw blades:

For good cutting edge quality on the tooth exit side, a scoring unit is recommended. Set the cutting width of the scoring circular saw blade to be slightly larger than that of the main circular saw blade so that the exiting tooth of the main saw no longer touches the cutting edge. A safe, flat support of the workpieces is only guaranteed with pressure device. Use split scoring circular saw blades for table and sliding table saws.

4 10 SB main saw blade = nominal SB of the scoring unit

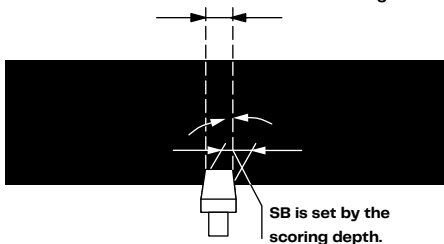

Panel splitting machine with scoring unit and pressure device (see Fig. 4 12)

Operating diagram of the conical scoring circular saw blade (see Fig. 4 13). For the maintenance of the tools (always in sets), the cutting widths (SB) must be aligned with one another.

Milling – Edge processing

Cutting with handheld tools

For straight cuts with hand-held circular saws, use a stop bar or guide rail. Use saw blades suitable for hard metal. The sawing takes place from the panel underside, using variable tooth for coarse cuttings and flat tooth/trapezoid tooth for clean cuts of Max Compact Interior and panels bonded on both sides.

Example: 7 1/4" Circular Saw – 40 tooth Laminate Blade.

Note: Leading Edge of panel must be chamfered on all projects!

Edge processing by hand

Files are suitable for edge processing. The filing direction goes from the decor side to the core. Fine files, plane files, sandpaper (100–150 grain) or scrapers are suitable for smoothing edges.

Edge processing with handheld machines

To mill bevels, use electric hand planes with a bevel or miter groove.

Hand routers are used for special tasks (e.g., recess for wash basin, trax coupling, etc.) with hard metal tools. To protect the Max Compact Interior surface, cover the supporting surface of the hand router with e.g., parts of a different panel, don't use felt! Carefully remove milling shavings.

We recommend using hard metal tipped milling cutters with indexable inserts. For better tool utilization, height-adjustable milling tools are preferable. Sharp edges are broken down afterwards.

Edge processing with stationary machines

When milling, pay attention to the optimal ratio of the number of teeth, cutting speed and feed rate. If the shavings are too small, the tool will scrape (burn), become dull and have a short service life. If they are too large, the edges will be wavy (strokes) and unclean.

High rotational speeds ensure good edge quality.

When working with hand fed machines, only use tools marked with "MAN" or "BG-TEST." Do not exceed or fall below the speed range indicated on the tool. Hand fed machines should only be used when working in the opposite direction.

Finishing milled edges: sand the edge surface and smooth out the sharp edges with sandpaper. Hand planes with steel residue can be used for finishing the edges. Use of an HSS blade is recommended (cutting angle: 15°).

For processing Max Compact Interior panels, use milling heads with HW indexable insert blades or diamond-tipped cutters.

- 4 10 Circular saw blades with positive rake angle and saw shaft under the workpiece
- 4 11 Circular saw blades with negative rake angle and saw shaft above the workpiece
- 4 12 Sliding table saw with scoring unit
- 4 13 Operating diagram

Joining



4 11



4 12

To join in climb and conventional milling (e.g., variable milling)

Machines used:

- Table milling machines
- Edge processing machines
- Double-end profiler (hand fed in conventional motion only)

Information on milling equipment:

- Milling head with reversible blades, divided cuts and reciprocal shaft angles for a splinter-free joining edge.
- This creates a cylindrical finish for large material thicknesses (approx. 0.1 mm)

The Diamaster WF 499-2 jointing cutter is recommended for absolutely straight cutting surfaces (see Leitz supplier information).

Low-noise joining on narrow workpiece surfaces in climb and conventional milling (variable milling)

Machines used:

- Edge processing machines
- Copy milling machines

Information on milling equipment:

- Composite tool with mutual shaft angle for a splinter-free joining edge and a straight narrow surface
- Noise reduction up to 5 dB(A) and highly efficient collection of shavings (over 95%)

- 4 14 Leitz joint milling head – indexable insert model
- 4 15 Leitz Diamaster joint cutter DP-tipped
- 4 16 Leitz spiral router machine marathon finish
- 4 17 Leitz Diamaster Plus router machine

Routers

For processing using routers and machining centers, use solid hard metal twist (VHW) or diamond-tipped (DP) router bits. Clamp workpieces well – if necessary, use additional mechanical clamps to support the suction cups. For maximum stability and rigidity, it is recommended to use ThermoGrip shrink-fit jaw chucks instead of collet chucks.

Good results can only be achieved if the machine is sufficiently stiff. "Light" radial machines are unsuitable, stiff portal machines are ideal.

Format, groove and finish milling

When high cut quality is required. Z3 model for high feed rates.

Machines used:

- Routers with/without CNC control
- Machining centers
- Special milling machines with milling spindles for use with shaft tools

Information on milling equipment:

- Marathon laminate for increased tool life and reduced tendency to form a built-up edge
- Use after roughing cutters, cutting allowance: 1–2 mm mirror grinding on the rake surface for processing

Router cutters for formatting and grooving with ledge-free cut

Machines used:

- Routers with CNC control
- Machining centers
- Special milling machines with milling spindles for use with shaft tools

Information on milling equipment:

- Negative rake angle of the blade for splinter-free finish when grooving and workpiece clamping for smaller parts
- Can be re-sharpened 5 to 8 times with normal blunting.
- Short, stable cutting blade therefore particularly suited for grooves and shaping of abrasive and hard-to-cut materials.



CNC Processing

Fixing panels on a machine table

There are basically two ways to fix or tension Max Compact Interior panels on machine tables depending on the type of processing to be performed. Shape-milled or edge-machined plate panels on both sides: Fixing by means of punctual suction cups (the proper distance between the suction cups must be observed!). Shape-milled, single-edge panel parts, hole and free-form milling: Fixing by means of an MDF protective board (can be used several times). The following applies for both options: It must be ensured that the suction cups provide sufficient holding power for the work to be performed. If the fixing is not enough: Check the sealing levels (e.g., sealing rings of the suction cups)!

Spacing of the suction cups

As a rule, the material being processed should not be subjected to any vibrations. Therefore, it is important that the suction cups are placed at an appropriate distance from the freely protruding panel edge. The more suction cups and the smaller the distance from the protruding edge, the cleaner the milling pattern. As a rule of thumb: Grids of max. 300 mm with a maximum distance from the free protruding edge of the panel of no more than 30 mm. An MDF protective board (e.g., 19 mm thick) provides the best results due to full-surface vacuum fixation on the machine table.

Choice of machining tool

The Max Compact Interior panel can be machined with solid carbide (VHM) as well as diamond (PCD) milling tools. The basic prerequisites for a clean milling pattern and a long service life are vibration-free tool holders and spindles. NOTE: The ball bearings must be properly maintained!

Diamond tools have proven particularly suitable for processing a large amount of panels or a high number of running meters. Smooth-running milling cutters with a shank diameter of min. 10 mm in combination with straight continuous DIA cutting edges are especially suitable for format milling. It is essential that the feed rate and the cutting speed be adjusted for the specific job and cutter based on the material being processed. We recommend always consulting the tool supplier (see table of guide values for sizing, drilling, etc.).

Clamping system of the milling tool

It is essential that the spindle be centered in the chuck to ensure the smooth running of the milling cutter. The more centered and play-free the milling cutter can be clamped in place, the better the result. Most machines are equipped with common tool holders such as collets, hydro grips or shrink chucks. For the professional CNC machining of larger jobs, a hydro grip tool holder or shrink chuck is recommended as they guarantee the best tool clamping. It is important to ensure the proper maintenance of all moving parts such as plain and ball bearings in order to avoid vibrations!

Extraction

The extraction or the extraction power must be adjusted accordingly for the material being processed to ensure that all the shavings are optimally removed. If the extraction is not strong enough, there is a risk of heat development. This is due to shavings that remain between the cutter and the panel edge. If the cutter can no longer eject the material, high friction and burn marks will occur at the edge of the panel.

CNC machining by Fundermax

Fundermax Compact Elements offers processing of Max Compact Interior, Max Compact Exterior, Max HPL and m.look. Please direct inquiries to the appropriate Customer Service Center (KSC) team.

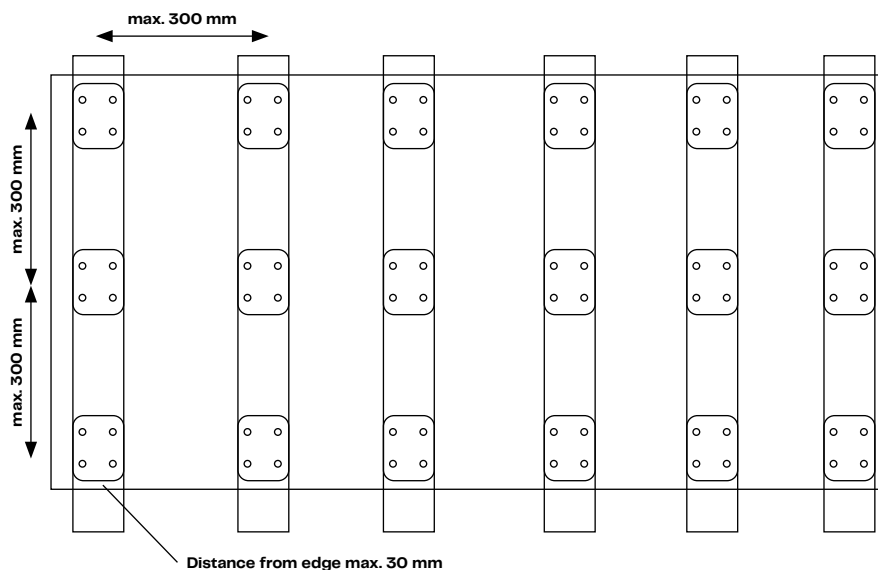

Edges and grooves

Grooved edges on Max Compact Interior panels should always be beveled, not sharp-edged! This spares the corners of the machine (indexable inserts) and prevents a notch effect. The service life can decrease depending on the height adjustment, the machine type and form, the cutting requirements and support material. For high volume production, the use of diamond-tipped machines should be considered.

Inner notches and cut-outs

Always round off corners – sharp-edged corners lead to cracking. The inner radius should be kept as large as possible (minimum radius 5 mm). For inner notches and milling grooves with a side length of over 250 mm, the radius must be gradually increased in line with the side length. Inner notches can be made with the milling cutter or pre-drilled before the cutout is sawn out from hole to hole.

All edges must be ripple free. If sharp-edged corners are required, this can be achieved by combining cut Max Compact Interior panels. The suitable cutting, milling and drilling machines are described in the previous sections.

Sanding the edges

With the usual machines, grain 100–120. Also possible by hand with sandpaper or scraper. Embed black panel edges with silicone-free oil to provide uniform color.

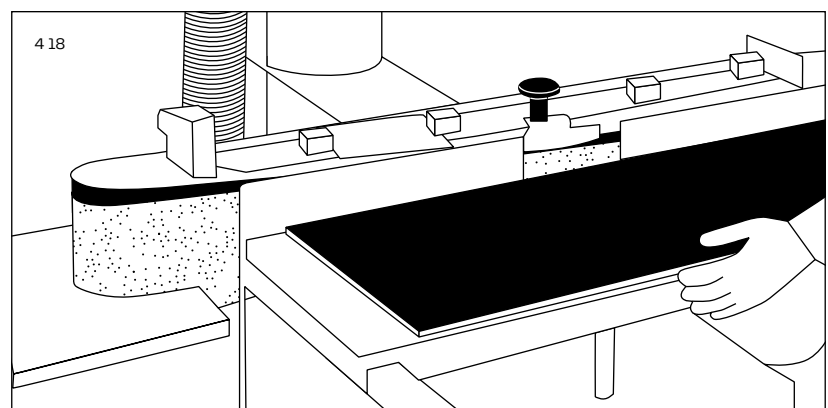
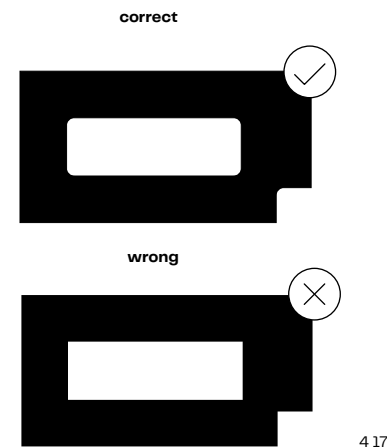
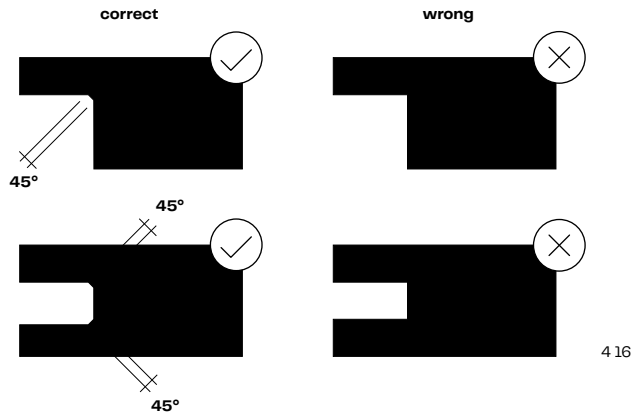

- 4 19 Grooved edges Max Compact Interior panels
- 4 20 Milling grooves Max Compact Interior panels
- 4 21 Edges Max Compact Interior panels

Examples of edge and corner designs

For Max Compact Interior panels no edge protection is necessary.

Current data sheet of the processing options can be found under www.fundermax.com.

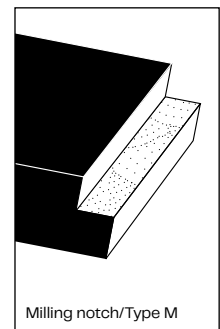
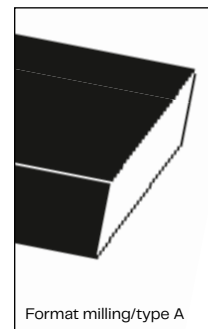
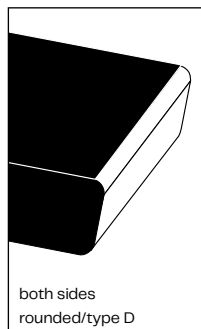
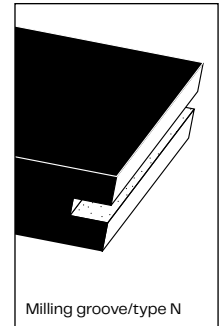
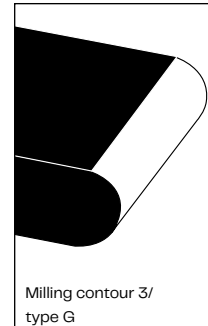
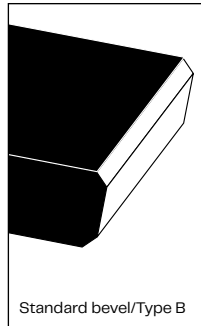

Tool suppliers

Austria

Leitz GmbH & Co. KG
Leitzstraße 80
A-4752 Riedau
Tel: +43 (0)7764 8200-0
Fax: +43 (0)7764 8200-111
office.riedau@rie.leitz.org
www.leitz.org

OERTLI-LEUCO Werkzeuge GmbH
Industriepark Runa
A-6800 Feldkirch
Tel: +43 (0)5522 75787-0
Fax: +43 (0)5522 75787-3
info@oertli.at
www.oertli.at

Germany

Ledermann GmbH & Co. KG
Willi-Ledermann-Straße 1
D-72160 Horb am Neckar
Tel: +49 (0)7451 93-0
Fax: +49 (0)7451 93-270
info@leuco.com
www.leuco.com

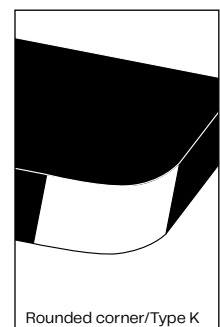
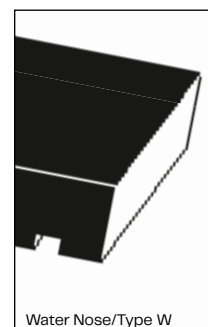
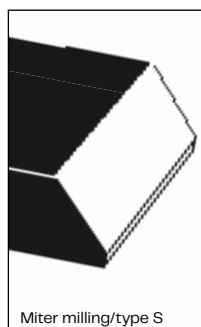
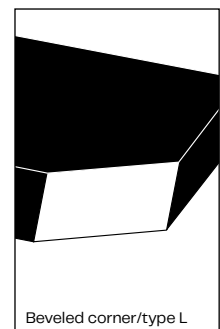
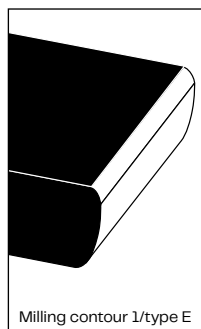

Drilling

4 19

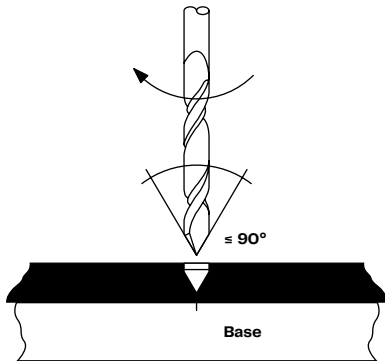

4 20

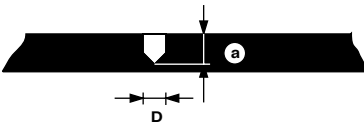

4 21



4 22

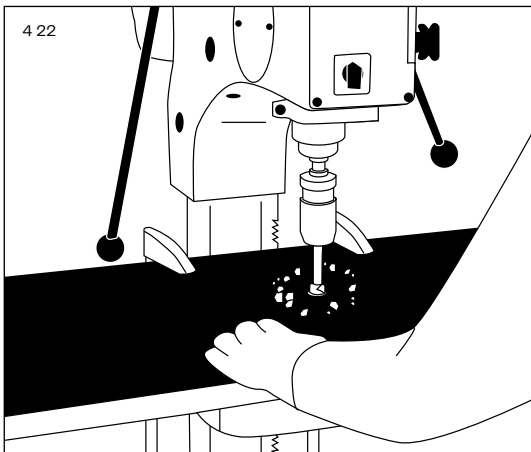

Solid hard metal twist (VHW) or dowel drills are used for drilling. In machining centers, the use of the main spindle instead of the drilling beams for a rpm of 2000 – 4000 min⁻¹ and a feed rate of 1.5 – 3 m/min, is recommended. Select the exit speed of the drill so that the melamine surface is not damaged. Shortly before the drill exits the workpiece in full diameter, the feed rate must be reduced by 50%. When drilling through-holes, the counter-pressure should be built up using hardwood or equivalent material to prevent break-offs of the melamine surface.

This is best achieved with drills for plastics, i.e. twist drills with an acute angle of $\leq 90^\circ$. They have a large pitch with large chip space, the steep tip allows drilling of through holes and they cut cleanly through the back of the material.

Note for blind holes perpendicular to the panel plane:

- Pilot hole diameter (D) = Screw diameter minus approx. 1 thread depth
- Drilling depth (a) = Panel thickness minus 2 mm after deduction of all tolerances
- Screw-in depth = drilling depth minus 1 mm

Note for blind holes parallel to the panel level:

- The residual thickness (b) of the Max Compact Interior panel must be at least 3 mm after deducting all tolerances.
- Select diameter of holes so that there is no splitting of the panel when screwing in the screws.
- Metal sheet and chip board screws are suitable.
- For more stability, make sure there is a minimum depth of 25 mm.
- It is imperative that tests to establish the correct drill diameter are carried out.

4 22 Twist drills with a point angle of $\leq 90^\circ$.

4 23 Screws perpendicular to the panel plane

4 24 Screws parallel to the panel plane

4 25 Box column drill

Universal drilling of blind and through-holes.

Machines used:

- Point-to-Point drilling machines
- Through-feed drilling machines
- CNC machining centers
- Box column drill
- Inlet fitting drilling machines
- Drilling units
- Hand drills

Information about the drill:

- Flat roof drill bits
- Shank diameter identical with blade diameter
- Adaptable for shaft-D 10 mm with reducing bush TB 110-0 or PM 320-0-25.

Tiered hinge drilling

Particularly for screw-in hinges in door manufacturing.

Machines used:

- CNC machining centers
- Drilling units
- Hand drills

Information about the drill:

- Model HW Z 2, 2-tiered
- 1st tier with roof drill bit

Drilling blind holes

In particular for dowel holes in cabinetry. Suitable for the tear-free drilling of blind holes in visible quality as well as the processing of panel materials.

Machines used:

- Point-to-Point drilling machines
- Through-feed drilling machines
- Inlet fitting drilling machines
- Drilling units
- CNC machining centers

Information about the drill:

- Roughing geometry with extremely clean cut
- Model HW-solid with highly wear resistant HW varieties
- High stability and long service life
- Polished chip space for minimal friction and feed force

Note:

In the case of manual drilling, better guidance can be achieved by pre-graining. Diamond-tipped drills are not suitable for Compact panels.

4 23



4 24



4 25

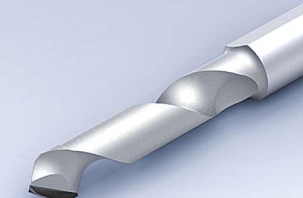

4 26 Leitz drill bit HW solid, Z 2

4 27 Leitz drill bit shaft 10 mm

4 28 Leitz drill bit shaft 10 mm

Screws

Screws should never come into contact with the edges of drillholes. They must have clearance on all sides so that the material can adapt to temperature and moisture fluctuations. In this way, the formation of cracks around the holes as well as panel warping, is avoided.

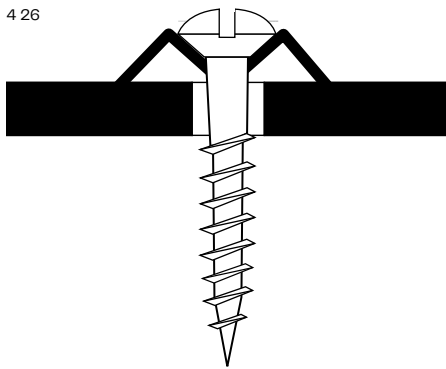

For lens head screws: use the underlay rosettes!

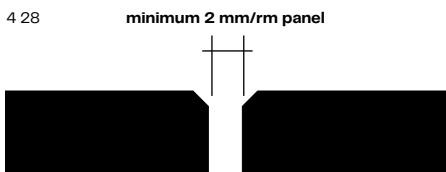
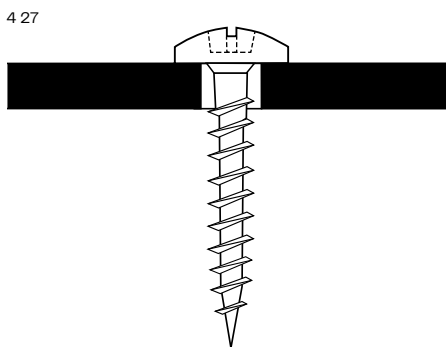

Attention to V-joints an expansion clearance on plat fragmentations!

Glued corner joints

In order to increase the adhesive surface, special bevel sections can be milled (Leitz) or joints with groove or external springs (Compact strips) can be produced.

During the adhesive process, it must be ensured that both bonded panels are joined in the same running direction.

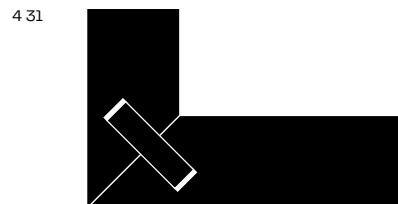
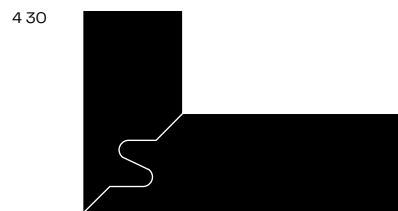
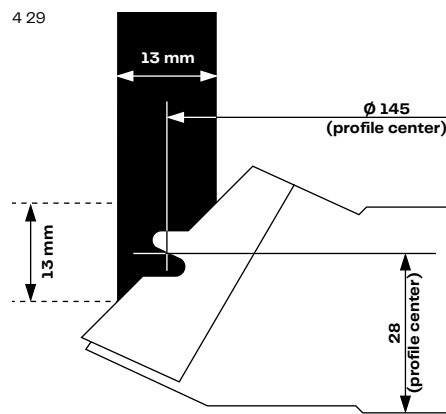

- 4 29 Lens head screw with underlay rosette
- 4 30 Rounded head screw covers slide points
- 4 31 V-joints with expansion clearance
- 4 32 Leitz profile cutterhead Pro 610-1-5
- 4 33 Corner joint with Leitz profile cutter
- 4 34 Corner joint with grooves and external springs

Gluing

Adhesive joints should be carried out in such a way that dimensional changes of the panels are allowed. The panels must only be bonded in the same running direction and conditioning, otherwise tensions may occur (tip: identify decorative design before cutting). Max Compact Interior panels have twice as much shrinkage and swelling room breadth wise than lengthwise. If adhesive joints are put under frequent pressure, they should be supported using mechanical joints.

Adhesives:

- Dispersion adhesives (e.g., PVAc glues = casein condensation)
- Resin adhesives (e.g., urea, resorcinol and phenolic glues)
- Contact adhesives (e.g., polychloroprene adhesives)
- Reactive adhesives (e.g., epoxy, unsaturated polyester, polyurethane adhesives)
- Hot melt adhesives (for edge banding, based on EVA, polyamide or polyurethane)

Gluing Max Compact Interior panels one below the other

Stiff adhesive joints – Reactive adhesives:

- Polyurethane
- Epoxy glue

Please note: These adhesives foam up and the surface of the panels must be cleaned before the adhesive dries. Once it dries only a mechanical cleaning is possible, which can damage the surface of the panel.

Dispersion adhesives (white glue) and condensation adhesives (PVA glues) are not suitable.

Elastic adhesive joints – PUR adhesive:

- Würth "glues and seals"
- Sikaflex 252
- Teroson – Terostat 92
- Dinitrol 600
- Dinitrol 605
- Dinitrol F500
- Dinitrol 410 UV Plus
- Fuller ICEMA 101/25 + curing agent 7

These adhesives are also suitable for supporting mechanical joints.

Gluing of Max Compact Interior with wood

After sanding the Max Compact panels, they can be bonded to wood materials using high-quality PVAc glues. Prerequisite: material must be able to absorb glue moisture during the setting process.

Glue application process

The Max Compact Interior panel, as well as the material to be glued, must be thoroughly cleaned before gluing so that there are no dust, grease, oil and sweat stains or coarse particles that can mark the surface after gluing. Ambient climate during bonding: 15–25 °C and 50–60% relative humidity.

The glue joint quality must be selected according to the bonding quality of the substrate and the load. Increased water resistance of the glue joint does not increase the water resistance of the substrate material!

The specifications of the selected adhesive manufacturer must be observed. It is always recommended to test the glue first under local conditions. Observe occupational health and safety regulations when working with adhesives, solvents and hardeners.

Press temperature

Tension-free composite elements can be produced most reliably at pressing temperatures of 20 °C, i.e. room temperature. Higher temperatures allow a reduction in the setting time. However, since the temperature also leads to dimensional changes that may vary between the Max Compact Interior panels and the other materials 60°C should not be exceeded in order to avoid increased stress which can lead to the distortion of the elements.

5 Chemical resistance

“Quality is always the best foundation.”

(Patricia Z., practice manager)



Max Compact Interior Panels

This product has hygienic, pore-free sealed surfaces made of melamine resin. Besides their excellent mechanical values, the Max Compact Interior panels mean a high temperature resistance, easy cleaning and a good resistance to chemicals. With the Max Compact Interior panels, the stain resistance requirements in accordance with EN 438 are met.

Resistance to:

- Lab and technical chemicals
- Solvents
- Disinfectants
- Dyes (certain types)
- Cosmetics

Particular attention must be paid to the careful processing of Max Compact Interior panels, as certain requirements may be imposed due to the particular field of use when constructing certain laboratory and medical facilities. The use of the Max Resistance² laboratory panels is recommended.

Max Compact Interior panels are resistant against many chemicals. However, several chemicals may still corrode the surface.

The following lists give an overview (without claiming to be complete) of the resistance of the panels (at room temperature) to the action of frequently occurring substances (solid, dissolved, liquid, gaseous). When using substances that are not listed, we ask that you inquire further.

To ensure you chose the right product, we strongly recommend that you clearly specify the chemical resistance requirements in advance.

Max Compact Interior panels

No damage

Max Compact Interior panels are resistant against the following substances and agents. These elements do not have an impact on the surface area, even after prolonged exposure (16 hours).

Substance	Chemical formula	Substance	Chemical formula	Substance	Chemical formula
Acetone	CH ₃ COCH ₃	Boric acid	H ₃ BO ₃	Gypsum	CaSO ₄ ·2H ₂ O
Activated carbon		Butyl acetate	CH ₃ COOC ₄ H ₉	Glucose	C ₆ H ₁₂ O ₆
Alum solution	KAl(SO ₄) ₂ ·12H ₂ O	Butyl alcohol	C ₄ H ₉ OH	Glycerine	CH ₂ OH-CHOH-CH ₂ OH
Aldehydes	RCHO	Cadmium acetate	Cd(CH ₃ COO) ₂	Glycine	NH ₂ CH ₂ COOH
Alcohols	ROH	Cadmium sulfate	CdSO ₄	Glycol	HOCH ₂ -CH ₂ OH
Alcohols, primary	RCH ₂ OH	Calcium carbonate (chalk)	CaCO ₃	Graphite	C
secondary	RR'CHOH	Calcium chloride	CaCl ₂	Uric acid	C ₅ H ₄ N ₄ O ₃
tertiary	RR'R''COH	Calcium hydroxide	Ca(OH) ₂	Urea solution	CO(NH ₂) ₂
Alcohols, primary		Calcium nitrate	Ca(NO ₃) ₂	Yeasts	
Aluminum chloride	AlCl ₃ .aq.	Carbolic acid	C ₆ H ₅ OH	Heparin	
Aluminum sulfate	Al ₂ (SO ₄) ₃	Chloral hydrate	CCl ₃ CH(OH) ₂	Heptanol	C ₇ H ₁₅ OH
Formic acid up to about 10%	HCOOH	Chlorobenzene	C ₆ H ₅ Cl	Hexane	C ₆ H ₁₄
Amide	RCONH ₂	Chloroform	CHCl ₃	Hexanol	C ₆ H ₁₃ OH
Amines, primary	RNH ₂	Cholesterol	C ₂₇ H ₄₆ OH	Hydroquinone	HOC ₆ H ₄ OH
secondary	(RR')NH	Cyclohexane	C ₆ H ₁₂	Hypophysin	
tertiary	(RR'R'')N	Cyclohexanol	C ₆ H ₁₁ OH	Imido "Roche"	
Ammonia	NH ₄ OH	Detergents		Immersion oil	
Ammonium chloride	NH ₄ Cl	Dextrose	C ₆ H ₁₂ O ₆	Inositol	C ₆ H ₆ (OH) ₆
Ammonium sulfate	(NH ₄) ₂ SO ₄	Digitonin	C ₅₆ H ₉₂ O ₂₉	Insecticides	
Ammonium thiocyanate	NH ₄ SCN	Dimethylformamide	HCON(CH ₃) ₂	Isopropanol	C ₃ H ₇ OH
Amylacetate	CH ₃ COOC ₅ H ₁₁	Dimethyl sulfoxide	(CH ₃) ₂ SO	Coffee	
Amyl alcohol	C ₅ H ₁₁ OH	Dioxane	C ₄ H ₈ O ₂	Potassium hydroxide solution up to about 10%	KOH
Aniline	C ₆ H ₅ NH ₂	Dulcitol	C ₆ H ₁₄ O ₆	Aluminum potassium sulfate	KAl(SO ₄) ₂
Arabinose	C ₅ H ₁₀ O ₅	Glacial acetic acid	CH ₃ COOH	Potassium bromate	KBrO ₃
Ascorbic acid	C ₆ H ₈ O ₆	Soil		Potassium bromide	KBr
Asparagine	C ₄ H ₈ N ₂ O ₃	Acetic acid	CH ₃ COOH	Potassium carbonate	K ₂ CO ₃
Aspartic acid	C ₄ H ₇ NO ₄	Ethyl acetate	CH ₃ COOC ₂ H ₅	Potassium chloride	KCl
p-aminoacetophenone	C ₈ H ₉ NO	Acetic acid isoamyl ester	CH ₃ COOC ₅ H ₁₁	Potassium hexacyanidoferrate	K ₄ Fe(CN) ₆
Baker's yeast		Ester	RCOOR'	Potassium iodate	KIO ₃
Barium chloride	BaCl ₂	Ethanol	C ₂ H ₅ OH	Potassium sodium tartrate	KNaC ₄ H ₄ O ₆
Barium sulfate	BaSO ₄	Ether	ROR'	Potassium nitrate	KNO ₃
Benzaldehyde	C ₆ H ₅ CHO	Ethyl acetate	CH ₃ COOC ₂ H ₅	Potassium sulfate	K ₂ SO ₄
Benzoic acid	C ₆ H ₅ COOH	Ethylene dichloride (dichloroethylene)	C ₂ H ₂ Cl ₂	Potassium tartrate	K ₂ C ₄ H ₄ O ₆
Benzol	C ₆ H ₆	Paints		Carbol-Xylene	C ₆ H ₅ OH-C ₆ H ₄ (CH ₃) ₂
Benzidine	NH ₂ C ₆ H ₄ -C ₆ H ₄ NH ₂	Greases		Potato starch	
Biogel		Formaldehyde	HCHO	Casein	
Lead acetate	Pb(CH ₃ COO) ₂	Fructose	C ₆ H ₁₂ O ₆	Ketones	RR'CO
Lead nitrate	Pb(NO ₃) ₂	Fodder		Table salt	NaCl
Blood		Galactose	C ₆ H ₁₂ O ₆	Caffeine	
Blood group test serums		Gelatine		Coal	

Substance	Chemical formula	Substance	Chemical formula	Substance	Chemical formula
Cosmetics		Nickel sulfate	NiSO ₄	Standard II nutrient broth	
Cresol	CH ₃ C ₆ H ₄ OH	Nicotine	C ₁₀ H ₁₄ N ₂	Starch	
Cresylic acid	CH ₃ C ₆ H ₄ COOH	-Nitrophenol	C ₆ H ₄ NO ₂ OH	Starch saline solution	
Copper sulfate	CuSO ₄ aq.	Nonne-Appelt-reagent		Stearic acid	C ₁₇ H ₃₅ COOH
Lactose	C ₁₂ H ₂₂ O ₁₁	Octanol	C ₈ H ₁₇ OH	Styrene	C ₆ H ₅ CH = CH ₂
Fructose	C ₆ H ₁₂ O ₆	Octyl alcohol	C ₈ H ₁₇ OH	Talcum	Mg ₃ Si ₄ O ₁₀ (OH) ₂
Lipstick		Olive oil		Tannin	C ₇₆ H ₅₂ O ₄₆
Lithium carbonate	Li ₂ CO ₃	Oleic acid	CH ₃ (CH ₂) ₇ CH = CH(CH ₂) ₇ COOH	Tea	
Magnesium carbonate	MgCO ₃	Organic solvents		Turpentine	
Magnesium chloride	MgCl ₂	Pandy's reagent		Carbon tetrachloride	CCl ₄
Magnesium sulfate	MgSO ₄	Paraffine	C _n H _{2n+2}	Tetrahydrofuran	C ₄ H ₈ O
Maltose	C ₁₂ H ₂₂ O ₁₁	Kerosene oil		Tetralin	C ₁₀ H ₁₂
Mannitol	C ₆ H ₁₄ O ₆	Pentanol	C ₅ H ₁₁ OH	Thiourea	NH ₂ CSNH ₂
Mannose	C ₆ H ₁₂ O ₆	Petroleum gasoline		Thymol	C ₁₀ H ₁₄ O
Seawater		Peptone		Thymol buffer solution	
Meso-inositol	C ₆ H ₆ (OH) ₆	Phenol and		Animal fodder	
Methanol	CH ₃ OH	Phenol derivatives	C ₆ H ₅ OH	Animal fats	
Milk, lactic acid	CH ₃ CHOHCOOH	Phenolphthalein	C ₂₀ H ₁₄ O ₄	Ink	
Lactose	C ₁₂ H ₂₂ O ₁₁	Polishing agents (creams & waxes)		Toluene	C ₆ H ₅ CH ₃
Mineral oils		Propanol	C ₃ H ₇ OH	Sound	
Nail polish		1,2-Propylene glycol	CH ₃ CHOHCH ₂ OH	Töpfer's reagent	
Nail polish remover		Pyridine	C ₅ H ₅ N	Dextrose	C ₆ H ₁₂ O ₆
Foodstuffs		Mercury	Hg	Trehalose	C ₁₂ H ₂₂ O ₁₁
Naphtol	C ₁₀ H ₇ OH	Raffinose	C ₁₈ H ₃₂ O ₁₅ ·5H ₂ O	Trichloroethylene	CHCl = CCl ₂
Naphtylamine	C ₁₀ H ₇ NH ₂	Rhamnose	C ₆ H ₁₂ O ₅ ·H ₂ O	Trypsin	
Sodium acetate	CH ₃ COONa	Castor oil		Tryptophan	C ₁₁ H ₁₂ N ₂ O ₂
Sodium carbonate	Na ₂ CO ₃	Rochelle salt		Urease	
Sodium chloride	NaCl	Cane sugar	C ₁₂ H ₂₂ O ₁₁	Urine	
Sodium citrate	Na ₃ C ₆ H ₅ O ₇ ·5H ₂ O	Soot		Vanillin	C ₈ H ₈ O ₃
Sodium diethyl barbiturate	NaC ₈ H ₁₁ N ₂ O ₃	Saccharose	= Cane sugar	Vaseline	
Sodium hydrogen carbonate	NaHCO ₃	Ointments		Water	H ₂ O
Sodium hydrogen sulfite	NaHSO ₃	Salicylaldehyde	C ₆ H ₄ OH-CHO	Watercolors	
Sodium hyposulfite	Na ₂ S ₂ O ₄	Salicylic acid	C ₆ H ₄ OHCOOH	Hydrogen peroxide 3%	H ₂ O ₂
Sodium nitrate	NaNO ₃	Saponin		Tartaric acid	C ₄ H ₆ O ₆
Sodium phosphate	Na ₃ PO ₄	Sulfuric acid	S	Xylo	C ₆ H ₄ (CH ₃) ₂
Sodium silicate	Na ₂ SiO ₃	Soap		Cedarwood oil thickened	
Sodium sulfate	Na ₂ SO ₄	Sorbitol	C ₆ H ₁₄ O ₆	Cement	
Sodium sulfide	Na ₂ S	Standard acetate solution		Zinc chloride	ZnCl ₂
Sodium sulfite	Na ₂ SO ₃	Standard I-Nutrient agar		Zinc sulfate	ZnSO ₄
Sodium tartrate	Na ₂ C ₄ H ₄ O ₆	Standard II Nutrient agar		Citric acid	C ₆ H ₈ O ₇
Caustic soda solution up to about 10%	NaOH	Standard I nutrient broth		Sugar and sugar derivatives	

Max Compact Interior panels

No damage under short exposure

Surfaces from Max Compact Interior panels remain unchanged when the following substances are spilled on them or if they are in contact for a short amount of time (removal within 10–15 minutes). Please note that the time of exposure is an important factor in the extent of corrosion on the HPL surfaces, even with diluted agents. As a result of the evaporation of the diluted material, the concentration of the substance increases over a period of time and the surfaces will be corroded, even though the concentration used will mostly be below those named in the following list. Focused sample tests are recommended.

Substance	Chemical formula	Substance	Chemical Formula
Formic acid over 10%	HCOOH	Varnishes and adhesives, chemically curing	
Amidosulfonic acid up to 10%	NH ₂ SO ₃ H	Methylene blue	C ₁₆ H ₁₈ O ₃
Aniline dyes		Millons reagent	OHg ₂ NH ₂ Cl
Inorganic acids up to 10%		Sodium hydrogen sulfate	NaHSO ₄
Arsenic acid up to 10%	H ₃ AsO ₄	Sodium hypochlorite	NaOCl
Boric acid	H ₃ BO ₃	Sodium thiosulfate	Na ₂ S ₂ O ₃
Iron (II) chloride solution	FeCl ₂	Sodium hydroxide solution over 10%	NaOH
Iron (III) chloride	FeCl ₃	Nylander's reagent	
Esbach's reagent		Oxalic acid	COOHCOOH
Fuchsin solution	C ₁₉ H ₁₉ N ₃ O	Phosphoric acid up to 10%	H ₃ PO ₄
Hair dyes and bleaches		Picric acid	C ₆ H ₂ OH(NO ₂) ₃
Iodine solution	I	Mercury (II) chromate	HgCr ₂ O ₇
Antiliming agents		Nitric acid up to 10%	HNO ₃
Potash lye over 10%	KOH	Hydrochloric acid up to 10%	HCl
Potassium chromate	K ₂ CrO ₄	Sulfuric acid up to 10%	H ₂ SO ₄
Potassium dichromate	K ₂ Cr ₂ O ₇	Sulfurous acid up to 10%	H ₂ SO ₃
Potassium hydrogen sulfate	KHSO ₄	Silver nitrate	AgNO ₃
Potassium iodide	KI	Sublimate solution (= mercury chloride)	HgCl ₂
Potassium permanganate	KMnO ₄	Hydrogen peroxide over 3–30% (perhydrol)	H ₂ O ₂
Crystal violet (Gentian violet)	C ₂₄ H ₂₈ N ₃ Cl		

High risk of damage

The following chemicals destroy the Max Compact Interior panel surfaces. They must be removed immediately, as they could also leave behind dull spots and coarseness even with a very short exposure time.

Substance	Chemical formula
In concentrations greater than 10%: Amidosulfonic acid	NH ₂ SO ₃ H
Inorganic acids, e.g.: Arsenic acid	H ₃ AsO ₄
Hydrogen bromide	HBr
Chromic sulfuric acid	K ₂ Cr ₂ O ₇ + H ₂ SO ₄
Hydrofluoric acid	HF
Nitrohydrochloric acid	HNO ₃ : HCl = 1 : 3
Phosphoric acid	H ₃ PO ₄
Nitric acid	HNO ₃
Hydrochloric acid	HCl
Sulfuric acid	H ₂ SO ₄

Aggressive gases

Frequent exposure to the following aggressive gases and vapors causes the Max Compact Interior surface to change:

Substance	Chemical formula
Bromine	Br ₂
Chlorine	Cl ₂
Nitrose fumes	N _x O _y
Sulfur dioxide	SO ₂
Acid vapors	

Max Compact Interior Plus

Max Resistance² (lab plate)

Sterilizability

Thanks to their excellent surface area, Max Compact Interior Plus panels are as easy to clean and just as easy to sterilize as, for example, stainless steel or OP tiles.

24 h chemical resistance test

Concentration of household solvents (decor independent)

Substance	Concentration
Hydrochloric acid	10%
Phosphoric acid	10%
Acetic acid	10%
Sodium hypochlorite	13%
Caustic soda	25%
Ammonia	25%

The product not only achieves SEFA3 standards for chemical resistance of horizontal laboratory worktops, but significantly exceeds them. Even hydrofluoric acid and highly concentrated nitric acid do not damage the panel.

Test procedure

The chemical resistance tests were carried out in a SEFA certified laboratory according to test method SEFA3-2010 Sec. 2.1. (24-hour exposure). Detailed information and results are available in the official test reports.

Results

Fundermax Resistance² passed the 24-hour endurance test and is proven suitable for use in laboratories. The product clearly exceeds the SEFA test criteria, as all its scores are better than 3.

Evaluation

- No influence (0):
No detectable change in the material surface
- Excellent (1):
Slightly detectable change in color or gloss, but no change in functionality or service life of the surface
- Good (2):
A clearly discernible change in color or gloss, but no significant impairment of surface life
- Fair (3):
Objectionable change in appearance due to discoloration or traces of etching, which may lead to deterioration of function in the long term

Acceptance criteria

To be approved as laboratory grade surfaces, tested materials should receive no more than four Level 3 ratings.

Max Resistance² (lab panels)

Substances	Evaluation			
	0	1	2	3
	No effect	Excellent	Good	Fair
Acids				
Acetic acid 99%	○			
Dichromate acid 5% ²⁾	○			
Chromic acid 60%	○			
Methanoic acid 90% ²⁾	○			
Hydrochloric acid 37%	○			
Hydrofluoric acid 48%		○		
Nitric acid 20%	○			
Nitric acid 30%	○			
Nitric acid 70% ²⁾			○	
Phosphoric acid 85%	○			
Sulfuric acid 33%	○			
Sulfuric acid 77%	○			
Sulfuric acid 96%		○		
Sulfuric acid 77% Nitric acid 70% (1 : 1)			○	
Alkali				
Ammonium hydroxide 28%	○			
Sodium hydroxide 10%	○			
Sodium hydroxide 20%	○			
Sodium hydroxide 40%	○			
Sodium hydroxide flakes	○			
Salts and halogens				
Saturated zinc chloride solution	○			
Saturated silver nitrate solution	○			
Tincture of iodine ¹⁾		○		

Substances	Evaluation			
	0	1	2	3
	No effect	Excellent	Good	Fair
Organic Chemicals				
Cresol	○			
Dimethylformamide	○			
Formaldehyde 37%	○			
Furfural ¹⁾		○		
Gasoline	○			
Hydrogen peroxide 3%	○			
Hydrogen peroxide 30% ²⁾	○			
Phenol 90%		○		
Saturated sodium sulfide solution	○			
Solvents				
Acetone ²⁾	○			
Amylacetate	○			
Benzol	○			
Butyl alcohol	○			
Carbon tetrachloride	○			
Chloroform ²⁾	○			
Dichloroacetic acid ²⁾		○		
Dioxane	○			
Diethyl ether	○			
Ethyl acetate ¹⁾	○			
Ethyl alcohol	○			
Methyl alcohol	○			
Methylene chloride	○			
Methyl ethyl ketone	○			
Xylene ¹⁾	○			

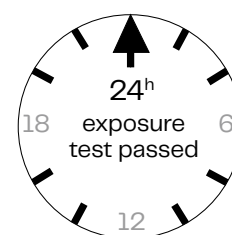

Test results may vary depending on decor.

1) Results on O082

2) Results on O085



Atrium Health's Cannon Pediatrics Translational Research Lab in Charlotte, NC | Photo Credit: Peter Brentlinger.
Product: Max Resistance² | Decor: White #0085 CTC | Architect: Little | Installer: New England Lab



David Rockefeller River Campus in New York, NY | SEFA Lab of the Year 2020 | Photo Credit: BICASA
Product: Max Resistance² | Decor: Pastel Grey #0074 | Architect: Jay Bargmann, Rafael Viñoly Architects

6 Cleaning



“Flawlessness is the most beautiful goal.”

(Matteo V., Architect)

Cleaning recommendation for compact and laminated panels

For unknown stains: perform basic cleaning and, if necessary, cleaning procedures A to G in sequence until the desired result is achieved. When cleaning with solvents: observe accident prevention regulations. Open windows. No open flames!

- **Basic cleaning:**

Clean surface with pure hot water, soft sponge, cloth or brush (e.g., nylon brush) – DO NOT scrub!

- **Cleaning procedure A:**

Same as basic cleaning, in addition use standard household cleaners without abrasives (e.g., dishwashing detergent – Palmolive, Fairy etc.; window cleaner – Ajax, Frosch etc.).

- **Cleaning procedure B:**

If contamination cannot be removed with A, use soft soap-water solution (1 : 3). Give it more time to take effect, depending on the degree of soiling.

- **Cleaning procedure C:**

Same as basic cleaning, but organic solvents (e.g., acetone, alcohol, nitro thinner, turpentine) can also be used. In case of heavier contamination, remove contamination mechanically. CAUTION: Avoid scratches, use a plastic or wooden spatula. Not suitable for high-gloss or deep matt (anti-fingerprint) surfaces.

- **Cleaning procedure D:**

Same as basic cleaning, but clean additionally with commercially available disinfectants. Steam cleaning is possible. Take care of the supporting material (e.g., wood beams, wall cladding, insulation, etc.) – avoid soaking!

- **Cleaning procedure E:**

Remove immediately! If necessary, perform C and final cleaning procedure.

- **Cleaning procedure F:**

Dry surface with soft cloth or sponge. If this does not remove the contaminants: use silicone remover (e.g., from Molto).

- **Cleaning procedure G:**

Following basic cleaning, in the case of extremely persistent lime contamination, acidic cleaning agents (e.g., 10% acetic or citric acid) can also be used.

- **Final cleaning:**

Cleaning agents need to be completely removed with plenty of water to avoid streaking. Wash with pure hot water and dry the surface with absorbent cloth or a paper towel.

Type of stain	Cleaning procedure	Type of stain	Cleaning procedure
Bacteriological contamination	D	Ballpoint pen	C
Mordant	C	Synthetic resin	E
Pencil	A	Varnish (graffiti)	C
Blood	D	Lipstick	C
Wax polish	B	Marking pen	C
Sealant (like silicone)	F	Fitting foam	E
Dispersion (PVAc)	C	PU foam	E
Emulsion paint	C	Rust	G
Water soluble paint	A	Shoe polish	C
Grease, oil	A, B, C	Soap residue	A
Grease fat	A	Spray paints	C
Felt-tip pen	C	Dust	A
Fingerprints	A	Stamping ink	C
Fruit juice	A	Tea	A
Urea glue	E	Tar (cigarettes)	C
Hybrid adhesive	E	Urine	D
Coffee	A	Wax crayon	C
Limescale	G	Wax polish	C
Adhesive	C	Wax residue	C
Water soluble adhesive	A	Water marks	G
Excrement	D	Two-component adhesive	E
Germs	D	Two-component lacquer	E
Chalk	A		

7 Wall cladding

**“It’s best to build upon
beauty from within.”**

(Rica Z., planner)





Max Compact Interior panels offer numerous design options for fixed as well as removable wall and ceiling cladding. This model has proven ideal for train stations, airports, subways, open entrance areas, as well as for covered areas at shopping centers.

Ventilated wall cladding with Max Compact Interior panels

The product of choice for classic ventilated wall cladding: Max Compact Interior with black core (also available in F-quality). Rear ventilation ensures control of temperature and moisture, particularly if there is still construction moisture in the walls or climatic variations in adjacent rooms.

An unequal climate in front of and behind the materials can cause the panels to warp. The solution is to mount the panel on a substructure to create a distance from the wall and allow the air to circulate (min. 20 mm rear ventilation). Make the necessary openings for air to flow in and out with a minimum cross-section of 50.0cm²/m.

Joints between the panels can be closed, but do not hinder their expansion clearance. It must be ensured that the air supply from below and the extracted air above the panels are free and that the resulting moisture variations will be balanced out by the circulation of air. Always review and comply with state building codes.

Construction information

- An assembly of the wall cladding directly to the wall and the installation of wall elements without substructure and rear ventilation is not allowed.
- The fire protection requirements of the respective country and project must be observed.
- When mounting the panel it must be ensured that the rear ventilation functions properly. Air circulation is only possible if there are areas for air to enter and exit.
- Protect material from stagnated water. The panel material must always be allowed to dry.
- When bonding Compact Panels to each other (edge adhesives or bevels), make sure that all parts have the same running direction.
- Protect substructure against corrosion/rotting.
- Arrange joints/components of the panels in such a way that installations are easily accessible.
- All edges within reach must be beveled to form V-joints.



7 01 Decorative wall cladding with rear ventilation

7 01

Fastening possibilities for wall cladding

There are different fastening possibilities for using Max Compact Interior panels as wall cladding. They can be screwed to wooden substructures, riveted to aluminum substructures or mounted with hanging strips made of wood or aluminum profiles.

Visible mechanical fastening

Note when using screws or rivets as fasteners: the center of the borehole in the substructure must correspond to the center of the borehole in the Compact panel. Start fastening the panels at the center of the panel and work outwards. Form sliding points and a maximum of one fixed point. Ensure sufficient expansion clearance. Joints between panels should be 2 mm per linear meter.

Sliding points

Depending on the necessary expansion clearance, drill the hole diameter for sliding points in the Compact panel larger than the diameter of the fastener. Shaft diameter of the fastener plus at least 2 mm per meter of cladding material starting from the fixed point. Fastener head must cover the drill hole. Set fasteners so that the panel can move. Set rivets with rivet gauge. The defined distance allows a movement of the parts in the borehole (clearance 0.3 mm). Do not overtighten screws. Do not use countersunk screws, use washers if required.

Sliding points for 6mm screws : 8mm for panels up to 9' in length, 9.5mm for panels > 9'.



Fixed points

Fixed points serve to evenly distribute (halve) the movements due to swelling and shrinkage. The drill hole diameter in the Compact panel is just as big as the diameter of the fastener.

Drill one fixed point per panel as close as possible to the center of the element. Make all other fastening holes sliding points. Fixed point (1 per panel) : 6mm.

Distance from edge

The edge spacings must be maintained for reasons of stability and flatness. To accommodate the dimensional changes, make panel joints at least 2 mm per meter of panel.

The stability of the cladding is determined by the substructure and thickness of the cladding material.

Maximum fastening distances

Panel thickness	AS	AW
8 mm	770,0 mm	620,0 mm
10 mm	920,0 mm	770,0 mm

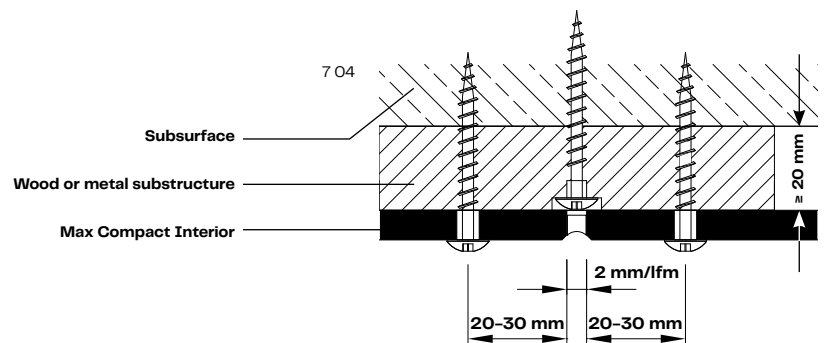
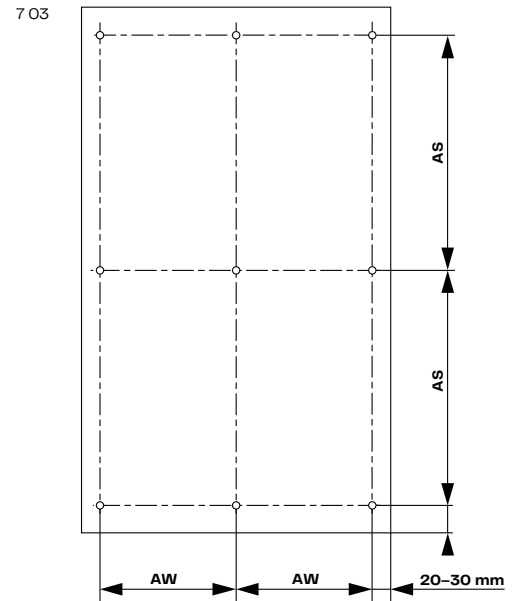

7 02 Wall cladding

7 03 Mounting distances

7 04 Type with rear ventilation and Max Compact Interior

Invisible mechanical fastenings

If you do not want the mounting fasteners to be visible, then Max Compact Interior panels can also be mounted on the wall with various suspension fasteners. The profiles can be attached by means of blind fasteners, screws and via spreader or threaded sleeves. Ideally, screws or sleeves with metal threads are used. The hole in the Compact panel must be predrilled one thread smaller.

It is important to space the horizontal suspension fastening in such a way that vertical rear ventilation is possible.

To avoid warping due to differences in tension, fixing strips must be spaced accordingly or made to slidable.

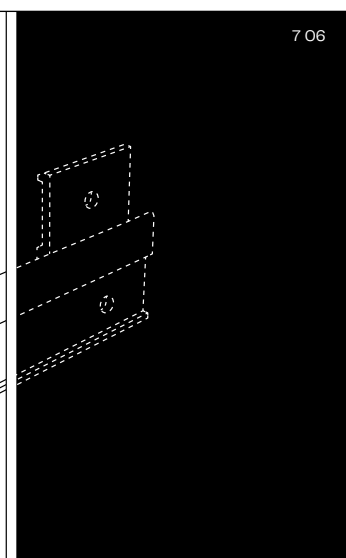
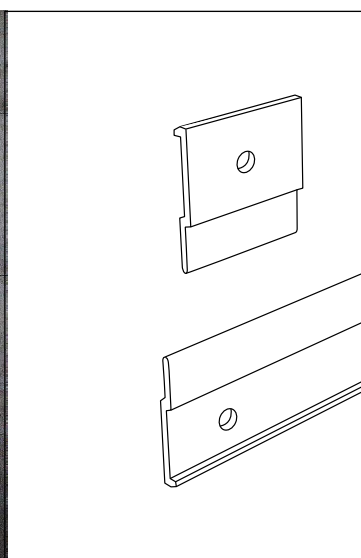

Ventilated wall cladding and wall protection with Z profiles

Panels provided with aluminum Z clips (thickness ≥ 10 mm) are hung in the flush mounted aluminum support frames (base and slope profiles). This allows for low depth of construction and easy disassembly.

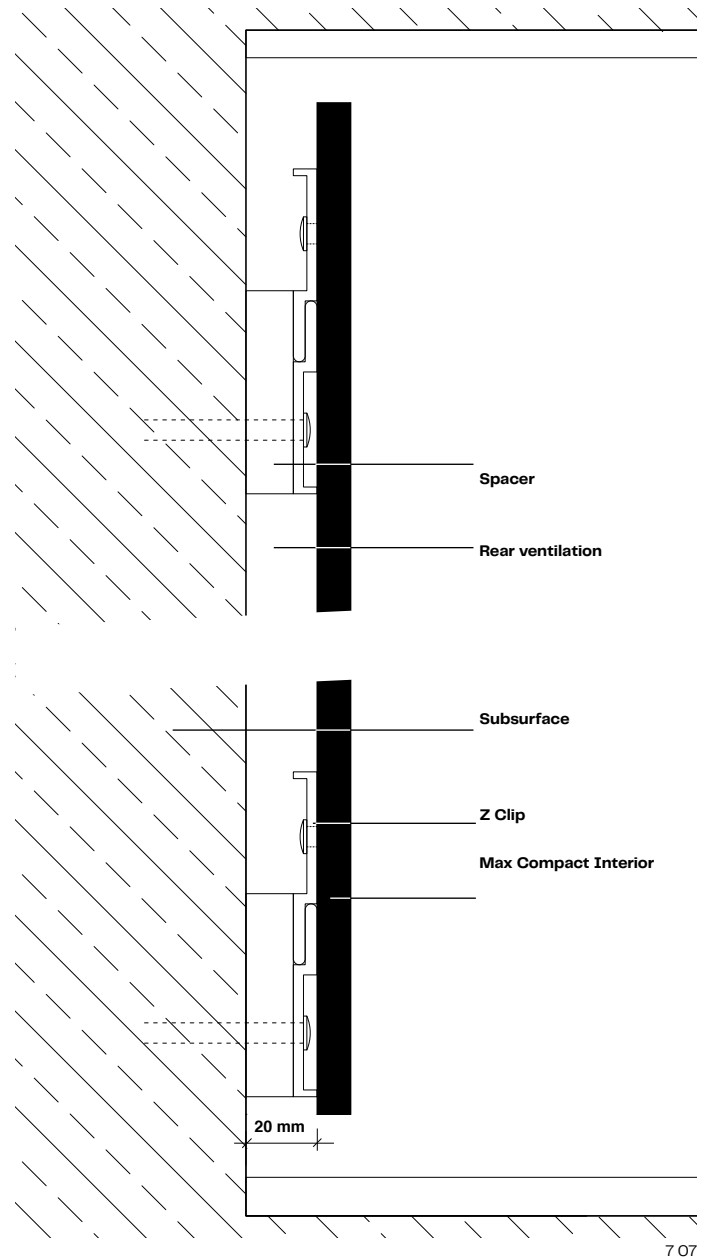

- 7 05 Wall cladding bathroom
- 7 06 Suspension fastening
- 7 07 Vertical section of ventilated wall cladding with Lohr wall protection profile

7 07

*** Important Notes for using Interior Systems with less than 3/4" airspace and less than 8mm joint spacing (ex. WPS/Monarch)

- Storage requirements from page 20-21 are required to maintain panel flatness.
- Conditioning requirements from page 20 should be closely followed.
- It is very important to consider wet spaces in opposing rooms, moisture migration through walls should be controlled.
- Entry and exit airflow requirements are critical to material performance.
- Fundermax panels may expand and contract up to 2mm/meter. The larger the panels, the more special consideration must therefore be given to these systems, as the effects are amplified.
- Any claims in areas with installed systems with less than 3/4" airspace will require HVAC conditioning reports be submitted.

8 Cubicles



“We want the best for the children – and for our facility.”

(Flora M., Teacher)



Due to their water resistance and hygienic surface, Max Compact Interior panels are suitable for use in wet room areas, as shower walls, for therapy cubicles and changing rooms. For these situations, there is a wide range of colors available from the Fundermax collection.



8 01

Technical notes on applications with Max Compact Interior panels

Protect the material from accumulating moisture during construction and installation – the panel material must be allowed to dry with sufficient air circulation in the cubicles. Ensure sufficient ventilation of the rooms.

When connecting Max Compact Interior panels with each other, make sure that the grain direction is the same (vertical with vertical and horizontal with horizontal). Leftover panel pieces should always be marked with the production direction. Support corner joints with anchors, springs, special milling, etc.

Construction of shower stalls: Do not expose Max Compact Interior door elements to direct water contact. To keep the door from warping, shower stalls should have an anteroom (e.g., shower cubicle with changing area and curtain as separation).

In case of heavy wetness: use mechanical corner connection and elastic, waterproof setting adhesive system!

Note:

Observe valid product portfolio. The construction elements described in this brochure are suitable for all areas of use of Max Compact Interior panels. Other profiles, screws, etc.: Only use those of stainless steel, brass or aluminum quality!

Fundermax reserves the right to make changes in the interest of technical progress.

- 8 01** Cubicles with shield on the front side
- 8 02** Cabin with separating wall supports
- 8 03** Cabin with separating wall supports, top view
- 8 04** shield on the front shield reaching to the ground
- 8 05** shield on the front side reaching to the ground, top view

Construction examples for changing rooms and restroom cubicles

The construction examples on the following pages merely show a few possibilities for cubicle construction. Requirements may vary depending on construction and fittings. Recommended panel thickness: 13 mm.

The following mounting distances apply for door hinge distances as well as the mechanical attachment of the Max Compact Interior panel to the wall and the Max Compact Interior panels to each other:

Panel thickness in mm	max A in mm	E in mm
13.0	600.0	20 – 100

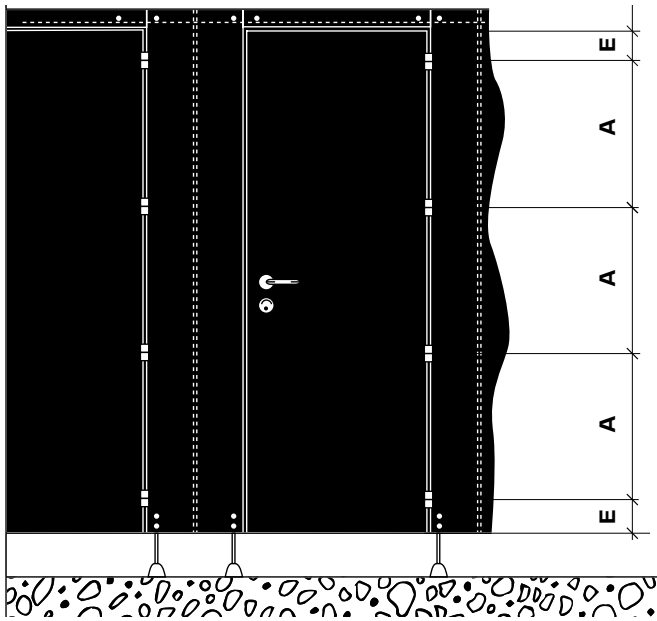

8 02

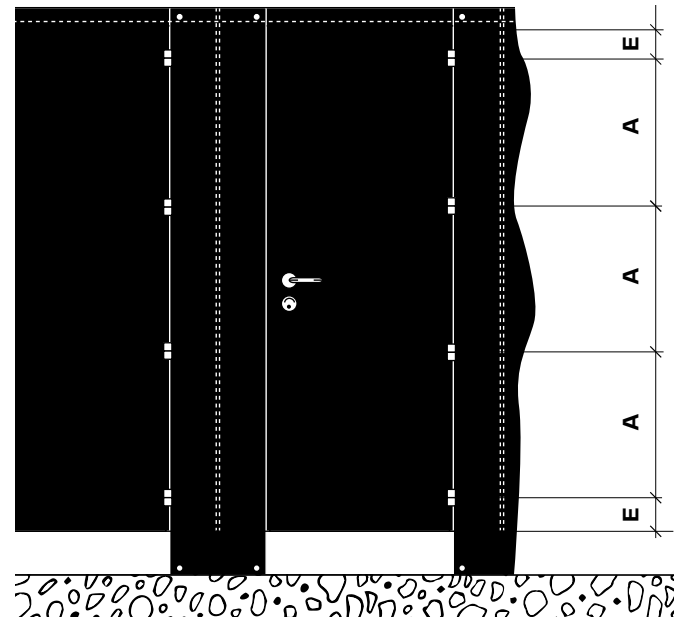

8 04

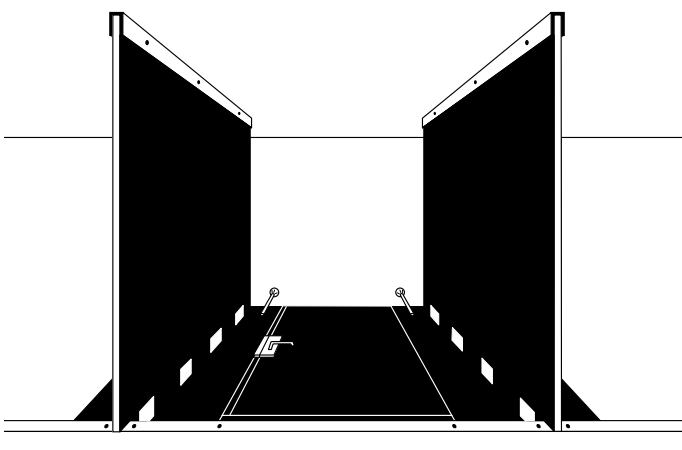

8 03

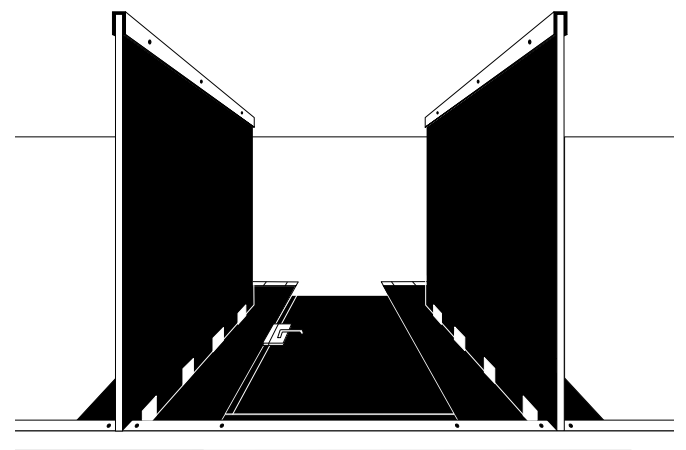

8 05

Construction Examples for Changing Rooms and Restroom Stalls

Construction Example Shower Divider

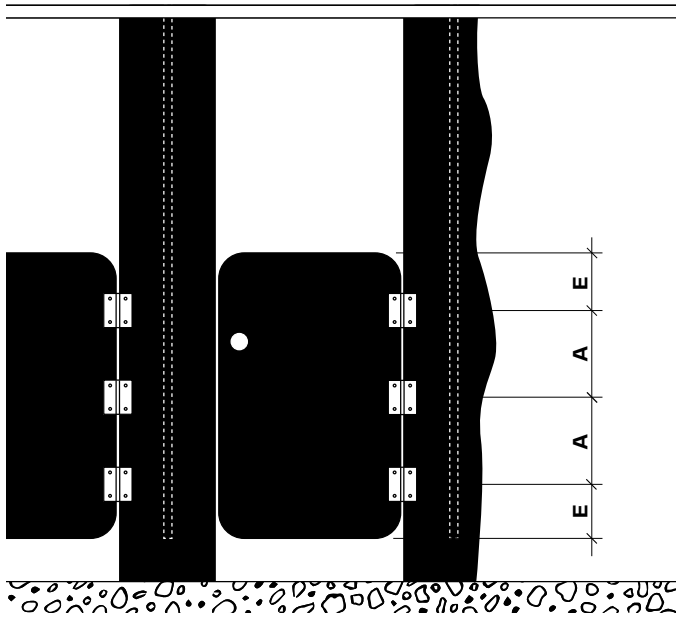

8 06

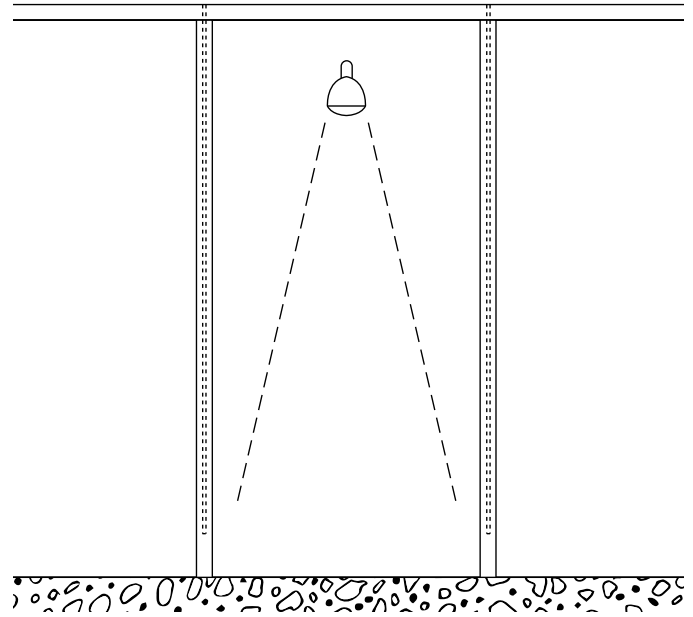

8 08

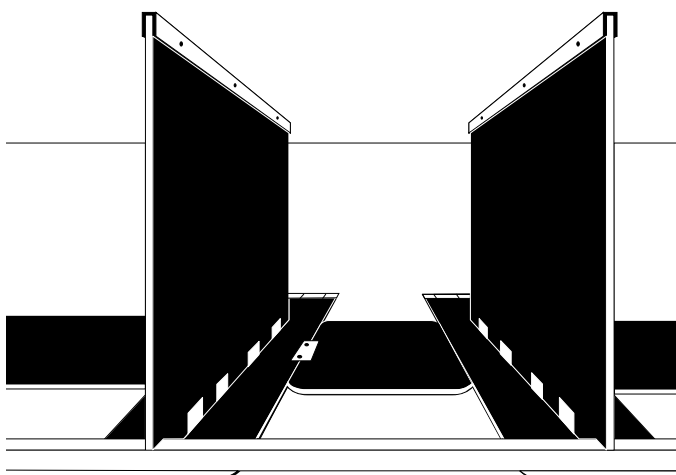

8 07

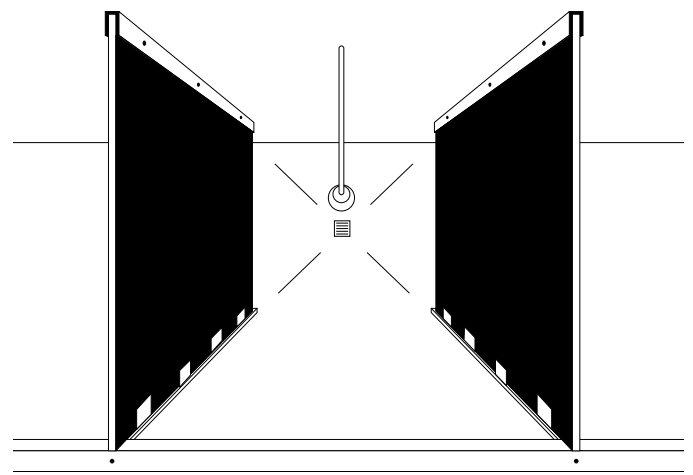

8 09

- 8 06** Cubicles with closing doors (spring hinges) for nursery school showers or changing rooms
- 8 07** Cubicles with closing doors, top view
- 8 08** Shower divider with uprights and lintel profile made from forming tube
- 8 09** Shower divider with uprights and lintel profile made from forming tube, top view

Construction details

Floor connections

In order to balance out uneven ground surfaces, but also to protect the Max Compact Interior panels from a build-up of water, foot supports from various suppliers are used (see suppliers/ accessories for cubicles p. 89).

Wall separating supports:

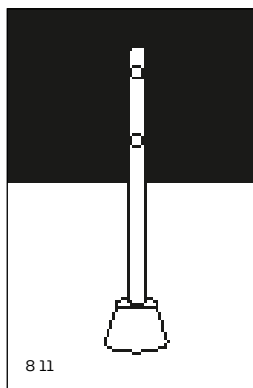
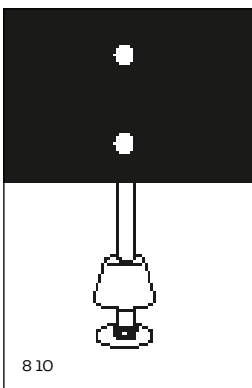

Wall separating supports with in-built height adjustment:

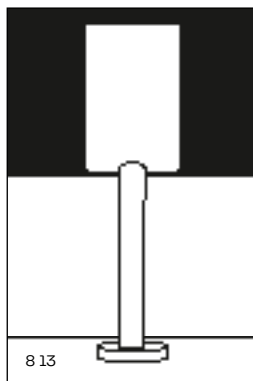

L-profile natural anodized aluminum:

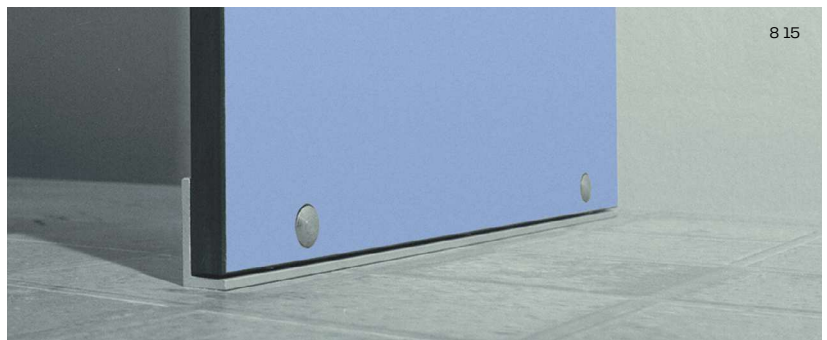
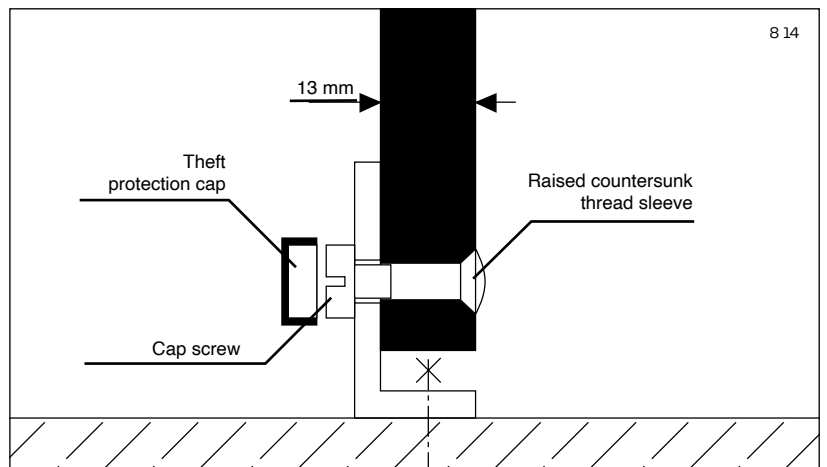

Floor connection for frontal uprights (for shower and screen walls) and cubicles:

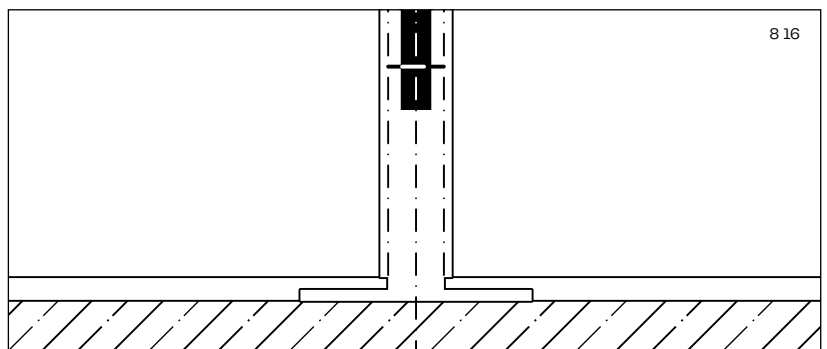

- 810 Supports with height adjustment, exterior view
- 811 Supports with height adjustment, interior view
- 812 Height-adjustment in-built supports, exterior view
- 813 Height-adjustment in-built supports, interior view
- 814 Vertical section floor connection with an L-profile
- 815 FLOOR CONNECTION WITH L-PROFILE
- 816 Vertical section floor connection with forming tube

Connections of separating agents

Wall mounting is usually done with angles made of aluminum, stainless steel or plastic.

Stainless steel wall connecting component with two black end caps:

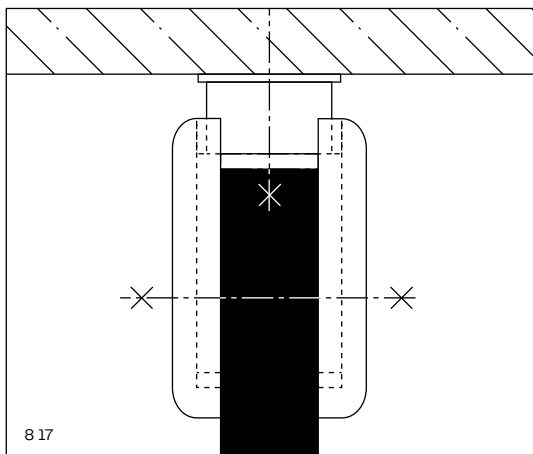

8 17

Wall separating connection brackets made from plastic for the connection of the front components, to the outside walls:

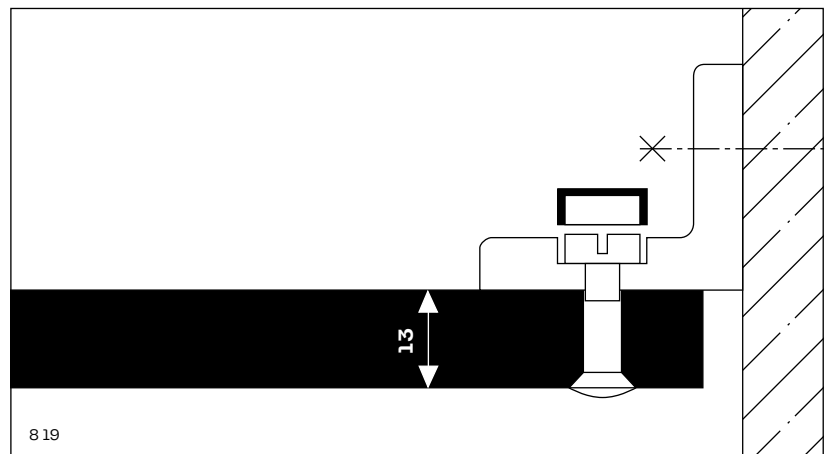

8 19

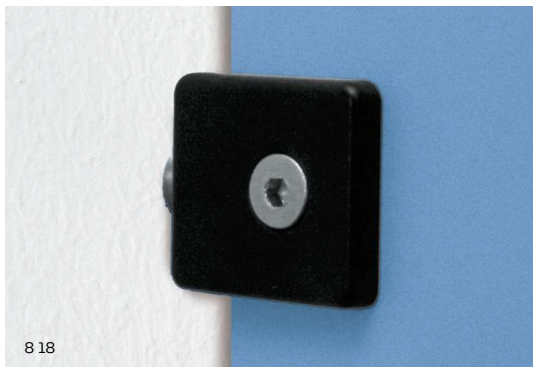

8 18

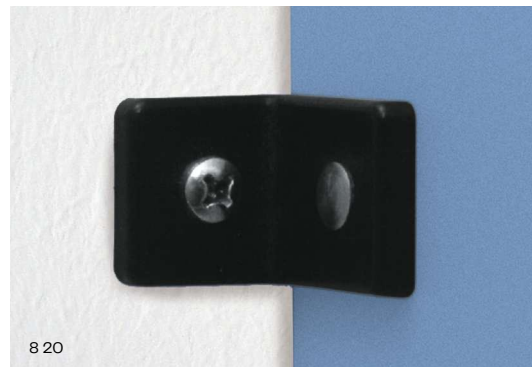

8 20

For larger expansion areas (≤ 12 mm), an adjustment is usually unnecessary. Access is, however, not possible.

- 8 17 Stainless steel wall connecting component, horizontal section
- 8 18 Stainless steel wall connecting component
- 8 19 Wall separating connection brackets made from plastic, horizontal section
- 8 20 Wall separating connection brackets made from plastic

Wall connections

U-profile anodized aluminum for a connection of the separating screens to the wall (13 mm Max Compact Interior panels):

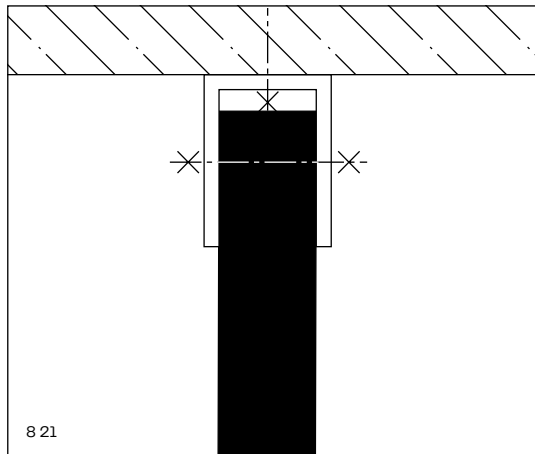

2 wall separating connection brackets made from plastic with 13 mm lights for Max Compact Interior panels:

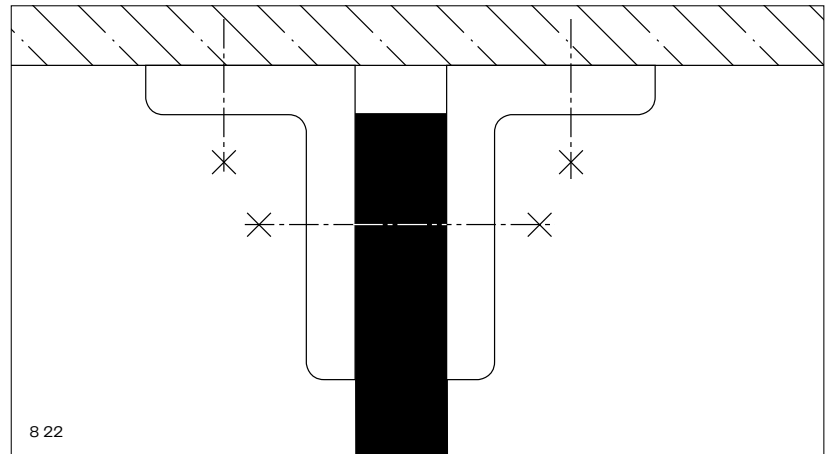

Trax coupling for the connection of the separating walls to the front screens with 2 black cover plates for 13 mm thick panels:

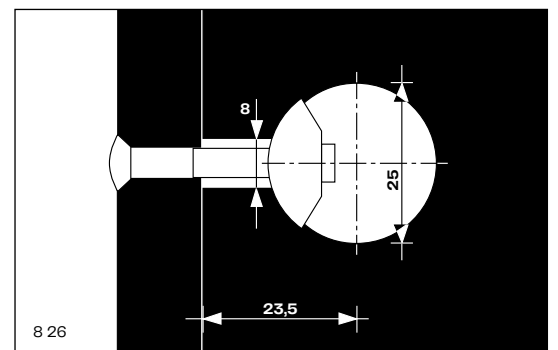
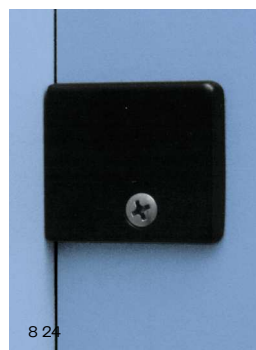
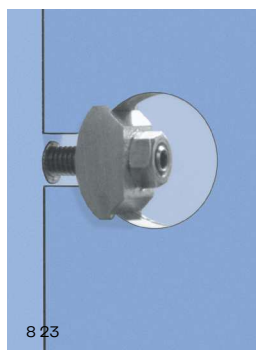

- 8 21 U-profile
- 8 22 2 Wall separating connection brackets made from plastic, horizontal section
- 8 23 Trax coupling open
- 8 24 black cover plate
- 8 25 Connection of the separating wall to the upright frame
- 8 26 Side view of the couple drilling

- 8 27 Vertical section of the lintel profile above
- 8 28 Door hinge
- 8 29 Support area for inwards opening doors a minimum of 80 mm high, in order to be able to hang the door; dimension A
- 8 30 View of milling out for coupling
- 8 31 Straining screw
- 8 32 Panel connectors
- 8 33 Horizontal section Over-panelling

Door support profiles and lintel profiles

Lintel profile:

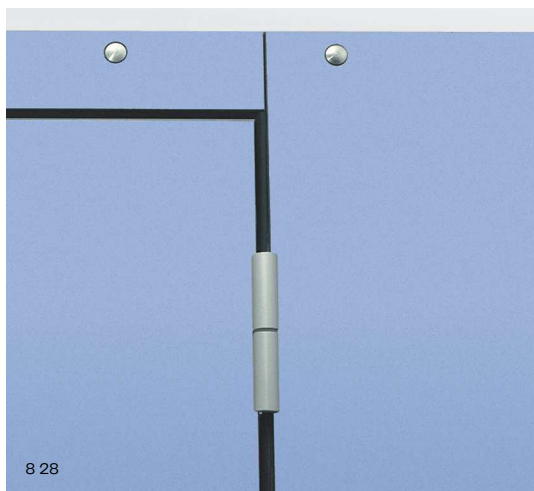
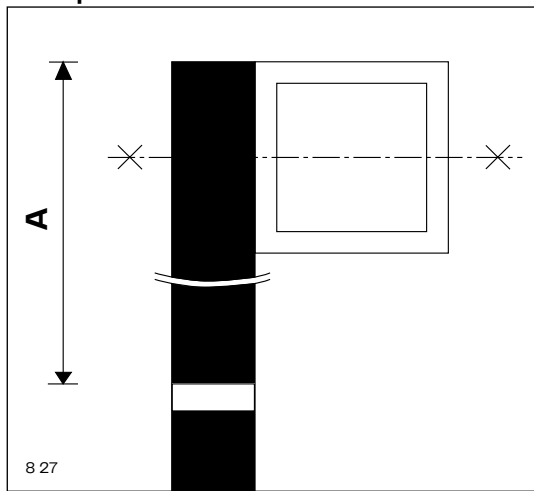

Panel connections

For the connection of Max Compact Interior panels; a separating wall panel thickness: 13 mm

Couplings for panel connections:

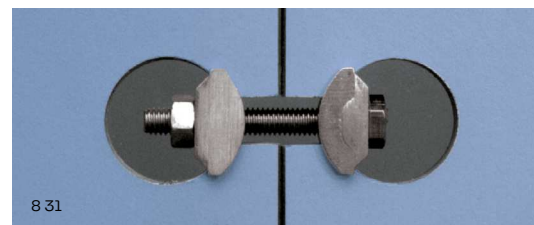
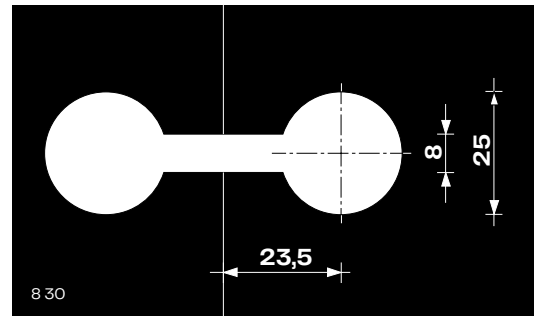

Over-panelling:

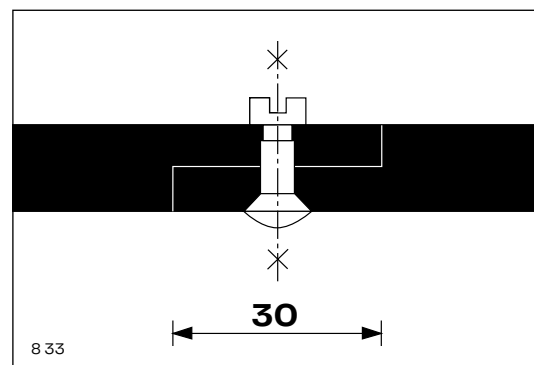

The over-panelling must be at least 30 mm wide. Gluing is done with PUR glue and 3 to 4 screws in addition. For wall wider than 1300 mm, a stiffening profile and a support must be provided.



Gym at the MHP (Myronivsky Khiboproduct) Offices in Kyiv, Ukraine | Photo Credit: Oleksiy Koluchkin
Product: Max Compact Interior | Decor: Electric #6010 | Architect: Yuriy Krasiy (The Skotch Group)



HOFistro Bistro Washroom Partitions in Althofen, Austria | Photo Credit: Hannes Kohlmeier
Product: Max Compact Interior | Decor: Custom Digital Print (Individualdecor)

9 Soffits and ceiling claddings

**“My work should, quite literally,
cause a stir.”**

(Sophie B., studying design)





Visible mechanical fastening with rivets or screws

Max Compact Interior panels can be mounted on an aluminum substructure using rivets or on a wooden substructure using screws. Due to the characteristics of the material, it is necessary to drill both fixed and sliding points.

Rear ventilation

As with soffits and ceiling claddings, sufficient rear ventilation must also be ensured (see chapter on wall cladding on p. 48).

Fixed points

Fixed points serve to evenly distribute (halve) the movements due to swelling and shrinkage. The diameter of the drill hole in the Max Compact Interior should be the same size as the diameter of the fastener. Drill one fixed point per panel as close as possible to the center of the element. Make all other fastening holes sliding points.

Sliding points

The diameter of the drill hole for the sliding points in the Max Compact Interior panel must be drilled larger than the diameter of the fastener, depending on the required expansion clearance. Shaft diameter of the fastener plus at least 2 mm per meter of cladding material starting from the fixed point. Fastener head must cover the drill hole. Set fasteners so that the panel can move. Set rivets with rivet gauge. The defined distance allows a movement of the parts in the borehole (clearance: 0.3 mm). Do not overtighten screws. Do not use countersunk screws, use washers if required.

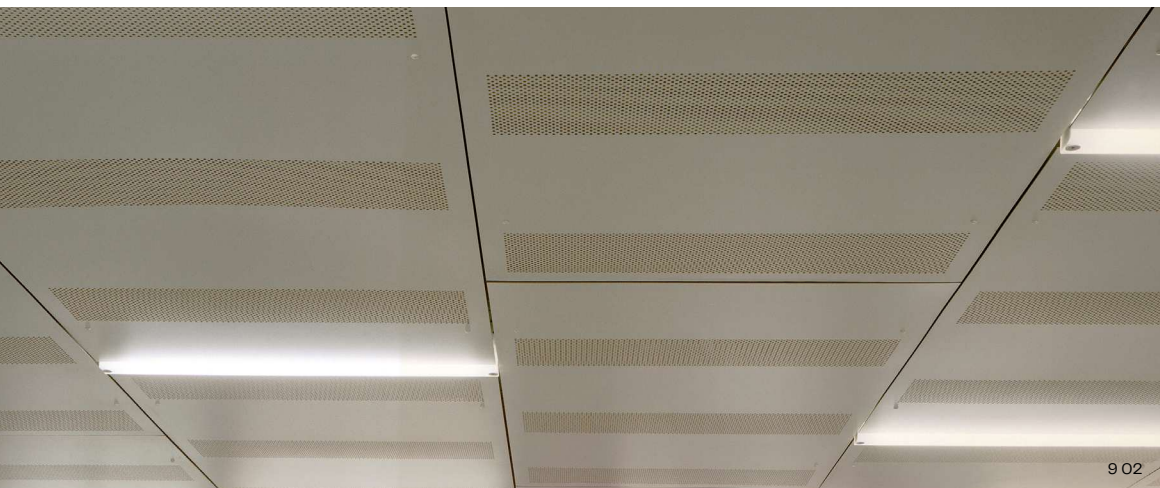
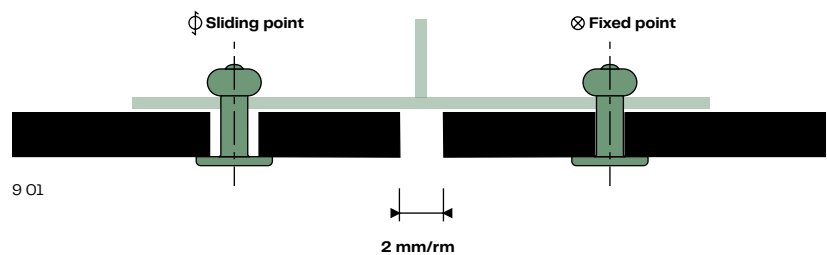

- 9 01 Example vertical joint
- 9 02 Suspended ceiling
- 9 03 Single span panel
- 9 04 Double span panel

Distance from edge

The edge spacings must be maintained for reasons of stability and flatness. The joints must be made at least 2 mm/m wide so that changes in size can take place without hindrance (see Fig. 10 2).

Mounting distances

These are to be chosen in accordance with the structural engineering requirements (calculations) or, if this is not necessary due to the local regulations, according to the Table.

Fasteners

It is essential that only fasteners made from noncorroding materials are used.

Max Compact installation screw with Torx 20 stainless steel X5Cr Ni Mo 17122 material No. 1.4401 V4A (painted head available upon request)

Diameter of the drill hole in Max Compact for installation with screw:

- Sliding points: 8 mm or as required
- Fixed points: 6 mm (1 per panel)

Alu-Blind rivet with big head color lacquered or with covering cap for wall claddings with Max Compact panels on aluminum substructures

Rivet sleeve: material-no. EN AW-5019 acc. DIN EN 755-2

Rivet pin: steel material-no. 1.4541

Pull-off strength of rivet pin: ≤ 5.6 kn

Diameter of drill hole in Max Compact for installation with rivets:

- Sliding points: 8.5 mm or as required
- Fixed points: 5.1 mm

Diameter of drill hole in the aluminum substructure: 5.1 mm The rivets must be put in place with a flexible mouthpiece, clearance 0.3 mm. The rivet, flexible mouthpiece and riveting tool must be suited to each other.

You will find suppliers of fasteners on page 100 or on our website: www.fundermax.com

For installation with mechanical fasteners

Panel thickness	maximum fastening spacing "b" single span panel	maximum fastening spacing "a" double span panel
8 mm	400 mm	450 mm
10 mm	450 mm	500 mm

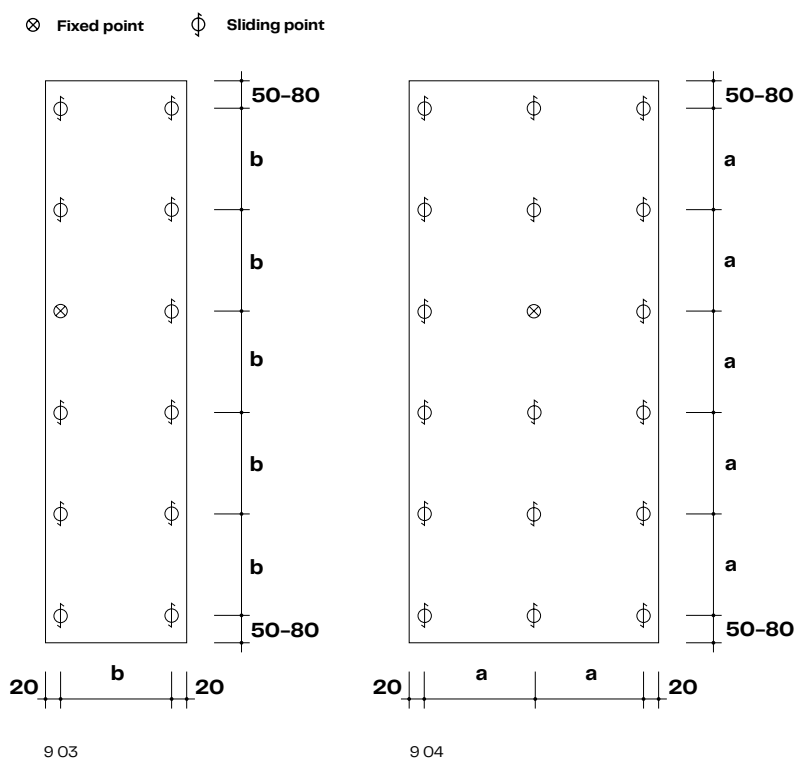

10 Table tops

**“We need to give space to ideas –
and the right table.”**

(Bettina F., entrepreneur)





Mounting distances

Max Compact Interior

Panel thickness	Mounting distance	Overhang
10 mm	320 mm	180 mm
12 mm	400 mm	250 mm

Application

Max Compact Interior panels are often used as table tops for school, desk, office, conference, lab or factory tables.

Resistance

Due to their pore-free surfaces and excellent chemical resistance, the panels are very easy to clean. Further advantages of these panels include their high scratch, tear and impact resistance.

Storage

Neither tables nor table panels should be stacked as the heavy stack weight can lead to damage.

Panel thickness

The thickness of the table top should either be 12 mm, or at least 10 mm, in order to allow enough depth for screwing. Both panel thickness and mounting distances as well as expected load platforms, are directly linked and must be measured correspondingly.

Mounting

Ensure that the installation is tension-free. Fastening can be done mechanically with screws that are either screwed directly into the panel or via sleeves with external and internal threads (e.g., Rampa sleeves). For this, the panels must be pre-drilled to establish a thread. Fastening the panels using screws takes place from the underside of the material. Therefore, metric thread and flat-head screws are suitable. Do not use countersunk screws, use washers if required.

Fastening points must be designed as sliding points. Based on how much space is needed for expansion, the diameter of the drill hole in the substructure should be that much larger than the diameter of the fastener. The screw head should always cover the drill hole. Set fasteners so that the panel can move. Do not overtighten screws. The center of the hole in the substructure must match the center of the hole in the Max Compact panel.

Drill with a centering aid! Start fastening the panels at the center of the panel and work outwards.

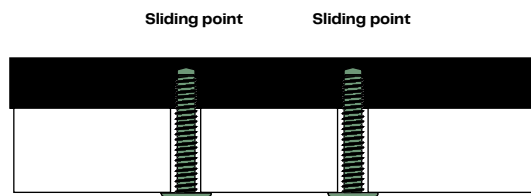

10 01

Examples when using Max Compact Interior 12 mm

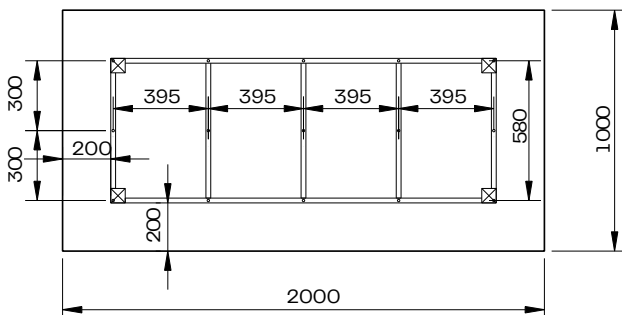

10 02

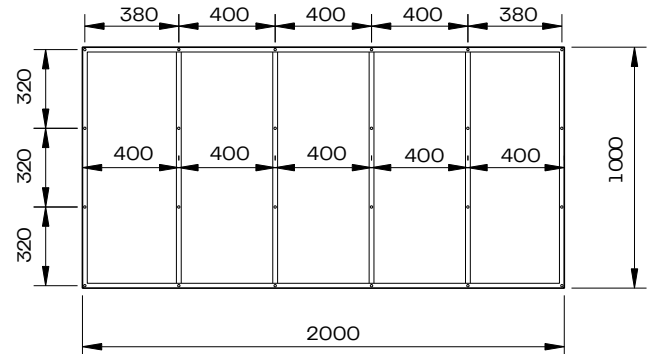

10 03

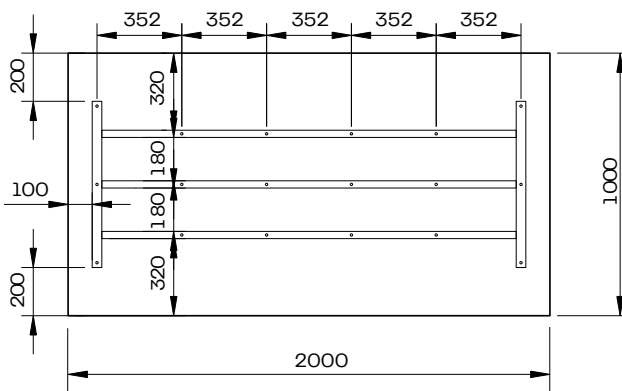

10 04

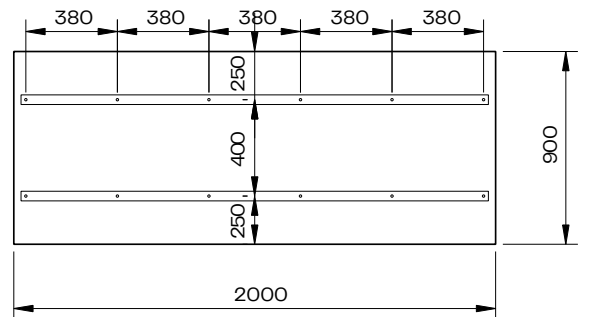

10 05

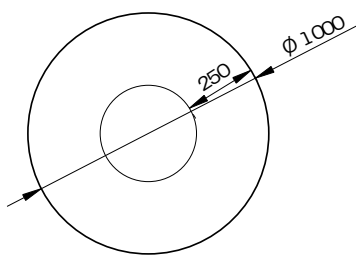

10 06

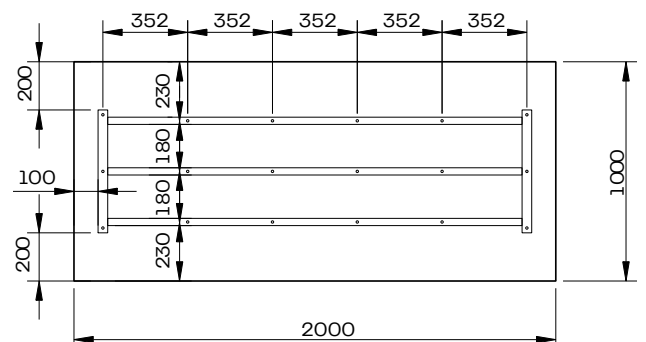

10 07

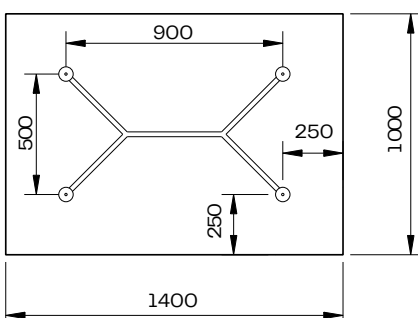

10 08

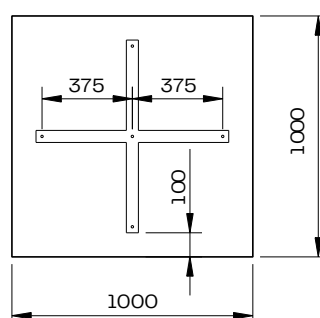

10 09

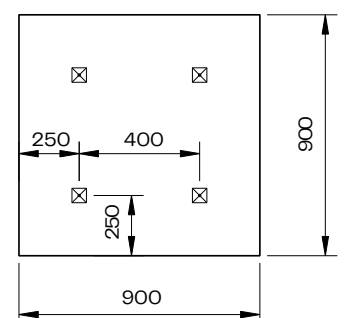

10 10

11 Furniture

**“The facility has to reflect my
creativity and quality.”**

(Philippa I., Interior Designer)





Cabinet body

Max Compact Interior is suitable for shop fittings, design applications, hospitals, or for home and office furniture.

In principle, the same panel connections used for conventional furniture construction can be used. It is not necessary to use the same panel strengths, but the connections must be made accordingly.

Due to the characteristics of the material, it is necessary to drill both fixed and sliding points. When using Max Compact Interior panels as corner joints (blunt or mitered), make sure that all parts have the same production direction. This means vertical with vertical and horizontal with horizontal. Mark production direction on any panel remnants.

Cabinet doors

There are only a few door hinges that are suitable for thin panels, which is why door elements can also be doubled up in the hinge area. To maintain symmetry, use the same panel material in the same thickness and decor.

Reactive adhesives, e.g., epoxy or solvent-free PU glues, are suitable for the adhesion process (see also Processing recommendations – Gluing).

- 11 01** Object hinge (from Prämeta company) for doors made of Compact panels, door thickness 10–13 mm; single-axis pivot point
- 11 02** Screw-on hinge for doors made of Compact panels
- 11 03** Angle, riveted
- 11 04** Angle, concealed screws
- 11 05** Connection with brass expansion bolt
- 11 06** Connection with tapped hole directly into the Compact panel
- 11 07** Screwed on the front side
- 11 08** Screwed on the front side, sectional view



Mechanical corner joints

Due to the usually low material thickness, it is best to fasten by means of screwing or riveting (blind rivets). Select drill hole diameters larger than the shaft diameters of the fasteners (dimensional changes). In keeping with the larger screw heads, use setting heads on rivets or washers.

Max Compact Interior corner joints can be produced along the entire length using brackets. This is necessary for very large surfaces and for supporting adhesive joints in wet rooms.

If screws are screwed into the back of the Compact panel from behind via the substructure, fixed and sliding points must be considered. A minimum panel thickness of 13 mm is necessary to ensure sufficient drilling material.

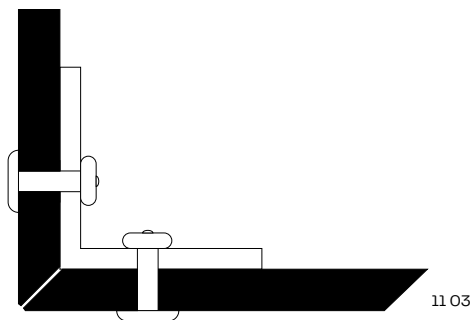

11 03

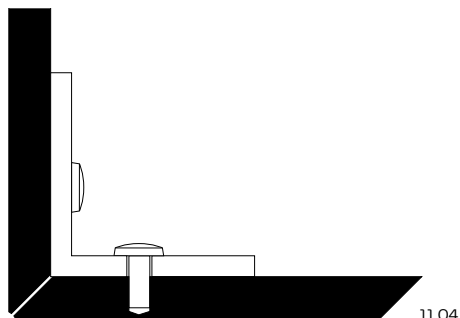

11 04

Other examples of mechanical connections

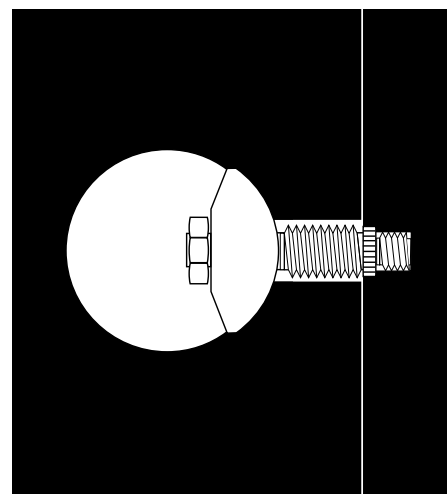

11 05

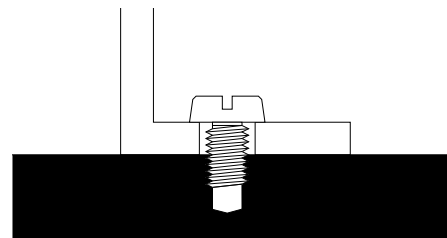

11 06

Thinner panels are drilled or riveted.



11 07

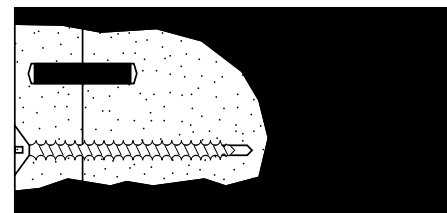

11 08

12 Worktops

“If you want staying power, you literally need the right foundation.”

(Jonas G., contractor)





Max Compact Interior as a worktop

Due to their high scratch and abrasion resistance as well as high impact resistance and resistance to high temperatures, Max Compact Interior panels are ideally suited for horizontal use as a worktop. Another advantage of these panels is the hygienically sealed, non-porous, closed surface made of melamine resin that is very easy to clean and is particularly resistant to many chemicals.

Panel thickness

For use as a worktop, the optimum panel thickness is 12 mm. Different panel thicknesses, fastening distances and the expected load capacity are all directly related and must be calculated accordingly.

Construction information

- Max Compact Interior panels shrink when releasing moisture and expand when absorbing moisture – take this into account during processing and construction.
- The dimensions are influenced by changes in relative humidity. It is therefore essential to ensure there is sufficient expansion clearance when installing the panels. Rule of thumb for the amount of expansion clearance needed:
2 mm for each meter of panel.
- When connecting Max Compact Interior panels to each other (corner joints butt or mitered), ensure that all parts to be connected are arranged in the same production direction (vertical with vertical and horizontal with horizontal). Leftover panel pieces should always be marked with the production direction.
- Base cabinets and substructures must have sufficient load-bearing capacity/stiffening. They should be aligned and height differences should be avoided.
- Do not make corner joints and worktop joints exclusively by gluing; these joints should always be supported by mechanical connections.
- Recesses/outlets for the sink, ceramic hobs, sockets, etc. must always have an inner radius of 5 mm. Pointed corners are not recommended.
- Protect material from accumulating moisture – the panel material must be able to dry. Ensure sufficient room ventilation.
- Visible edges or edges in the handle area must be chamfered or at least broken with sandpaper to avoid injuries and material damage.
- Do not mill into the surface – this maintains cleanability.
- Max Compact Interior panels with white core are not suitable for high traffic areas due to the increased visibility of soiling.

Note:

Fundermax reserves the right to make changes in the interest of technical progress.

Substructure

Ensure sufficient ventilation of both sides of the panel when installing. Different temperatures or moisture levels in front of and behind the countertop can cause the panels to warp.

To guarantee air circulation on the front and back of the panels, they should be placed on a sufficiently stable load-bearing substructure. If the base cabinets are not strong enough, they must be reinforced with additional elements. They should also be aligned and any height differences compensated for (e.g., by using a suitable spacer). For proper rear ventilation of Max Compact Interior panels, make the top of the kitchen cabinets open, so that air exchange can take place.

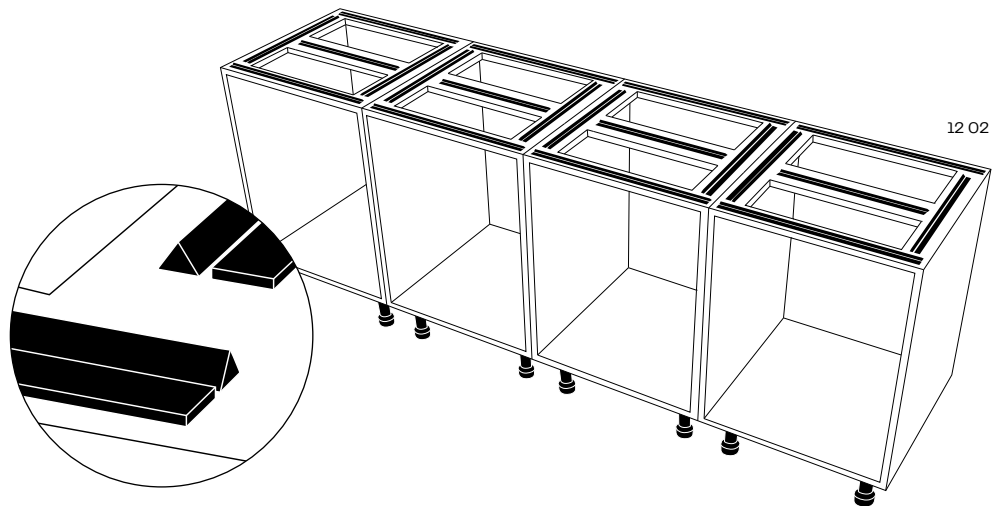

12 01 Example of mechanical fastening

12 02 Example of glued fastening

Mechanical fastening

Due to the material characteristics, the fixing points must be sliding points.

Fixed points

Fixed points serve to evenly distribute (halve) the movements due to swelling and shrinkage. The drill hole diameter in the Compact panel is the same as the diameter of the fastener. Drill one fixed point per panel as close as possible to the center of the element. Make all other fastening holes sliding points.

Sliding points

Based on how much space is needed for expansion, the diameter of the drill hole in the substructure should be that much larger than the diameter of the fasteners. The screw head should always cover the drill hole. Set fasteners so that the panel can move. Do not overtighten screws. The center of the hole in the substructure must coincide with the center of the hole in the Max Compact Interior panel. Drill with a centering aid!

Start fastening the panels at the center of the panel and work outwards. Ensure that the installation is tension-free. Fastening can be done mechanically with screws that are either screwed directly into the panel or via sleeves with external and internal threads (e.g., Rampa sleeves). For this purpose, predrill the panel one thread smaller than the screw or sleeve and observe the residual wall thickness of 2 mm (after deduction of all tolerances). Screws with a metric thread and a flat head are suitable. Do not use countersunk screws. If necessary, use washers if required.

Observe recommendations for drilling blind holes vertically and parallel to the slab surface in the chapter "Drilling" (see page 32).

Mounting

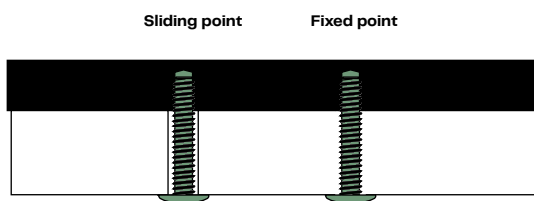

12 03

Fastening distances for mechanical fastening

Max Compact Interior

Panel thickness	Mounting distance	Distance from edge	Overhang
12 mm	550 mm	20-80 mm	50 mm

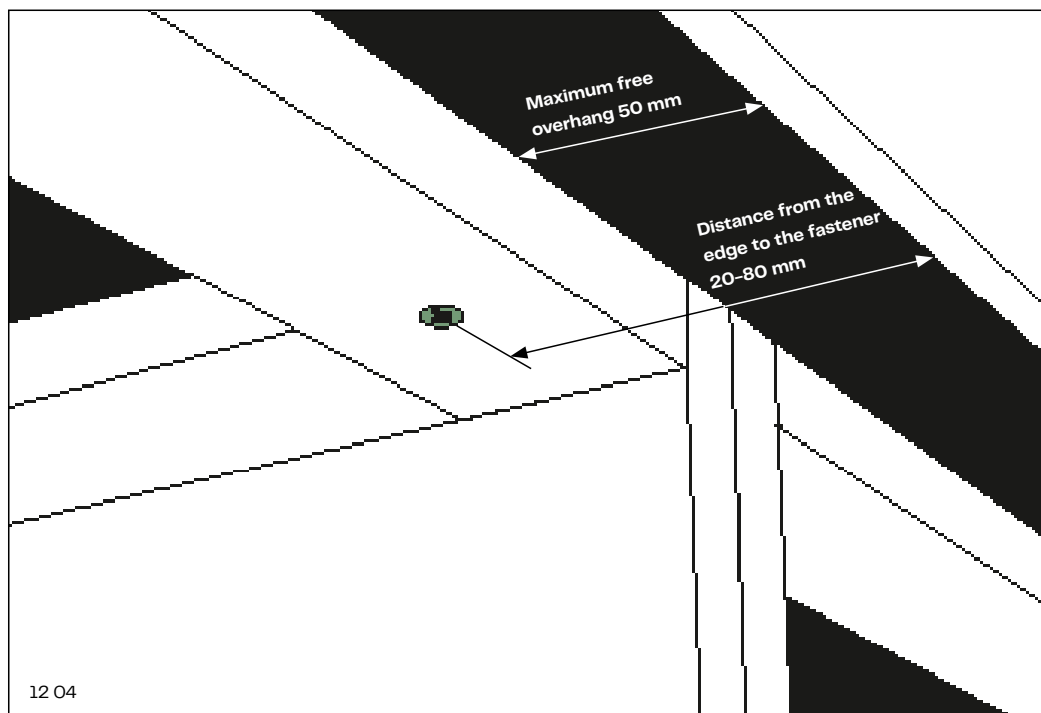

Glued fastening

As an alternative to hidden, mechanical fastening, facade adhesive systems from companies such as INNOTECH and SIKA are also suitable.

Recommendation for panel alignment: Peel off the cover film from only the corner of the double-sided adhesive tape. The weight of the panel can cause the tape to immediately adhere to the surface and make alignment more difficult.

Observe the processing guidelines of the adhesive manufacturer. Test the glue first under local conditions. Observe occupational health and safety regulations when working with adhesives, solvents and hardeners.

Fastening distances for glued fastening

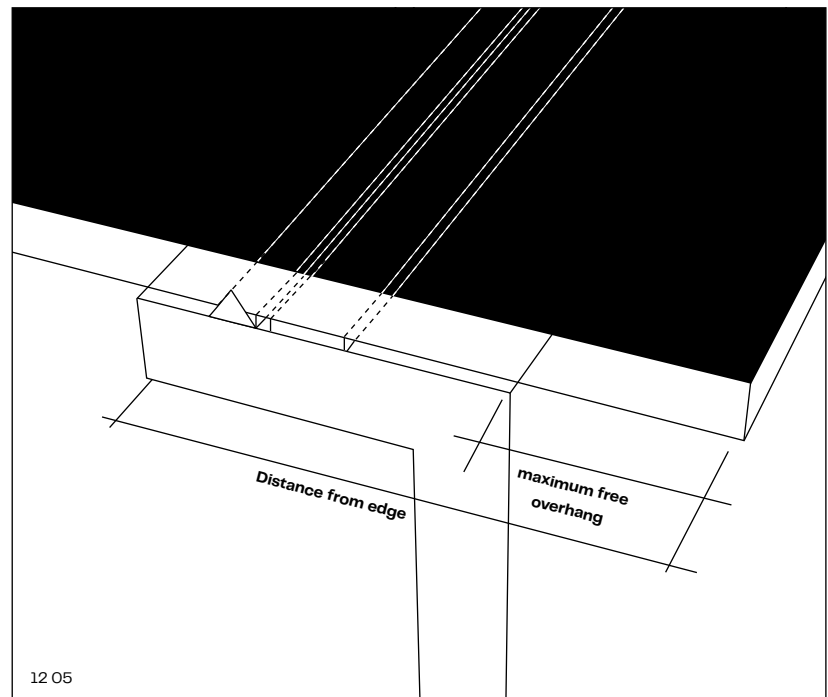

Max Compact Interior

Panel thickness	Mounting distance	Distance from edge	Overhang
12 mm	300 mm	20-80 mm	50 mm

Worktop joints

When making corner joints, it must be ensured that the kitchen base cabinets are aligned and any height differences should be compensated for using spacers. Level out worktop joints by means of a carpet pad. They must be made using suitable connection means – ensure that a wall thickness of 3 mm is maintained after subtracting all tolerances. Suitable connection means are anchors, grooves, biscuits, special milling, etc.

Observe the recommendations for drilling blind holes vertically and parallel to the panel surface in the chapter “Drilling” on page 32.

Using only glue for worktop joints is not recommended! Glued corner joints and worktop extensions should always be supported with mechanical connections.

When making worktop joints and connections to other furniture parts, walls, etc., observe the necessary expansion clearance for tension-free movement of the Max Compact Interior panels.

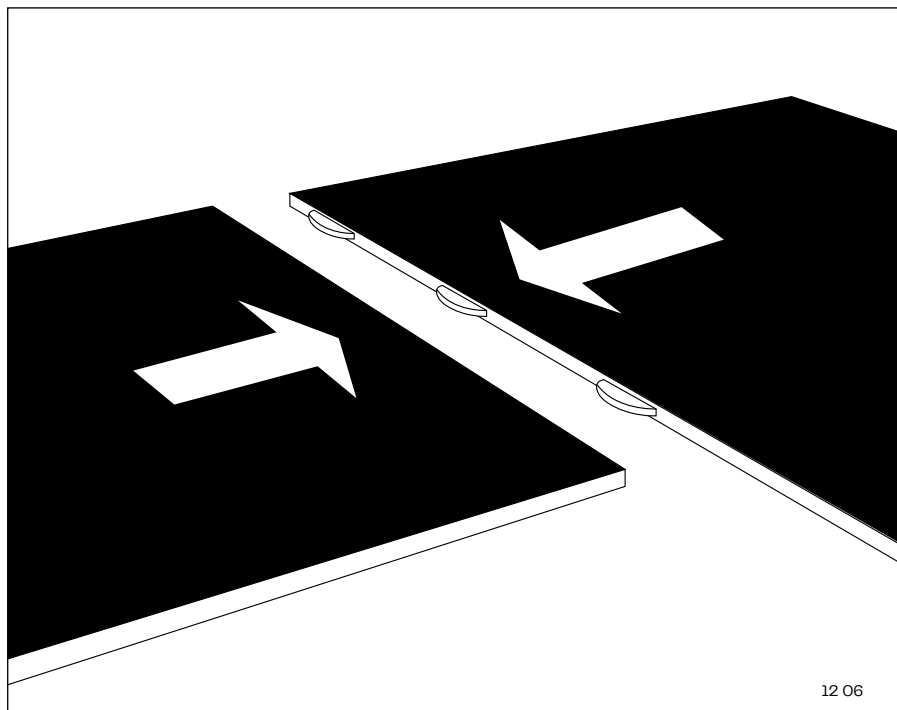

Sink and Glass Top Stove Installation

Installation instructions

- Ensure sufficient expansion clearance. Rule of thumb: 2 mm/rm.
- Recesses/outlets must always be made with an inner radius of at least 5 mm. Pointed corners are not recommended.
- Ensure that all loads can be borne by the entire structure (e.g., with a full sink).
- When milling the Max Compact Interior panels, make sure that at least 50% of the panel thickness remains (e.g., 12 mm worktop – maximum milling of 6 mm). Otherwise, the worktop must be supported with a suitable substructure.
- Do not mill into the surface – this maintains cleanability.



Installation of Glass Top Stoves

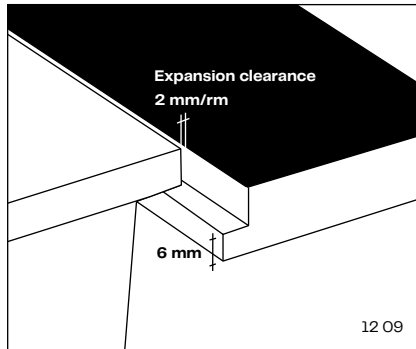
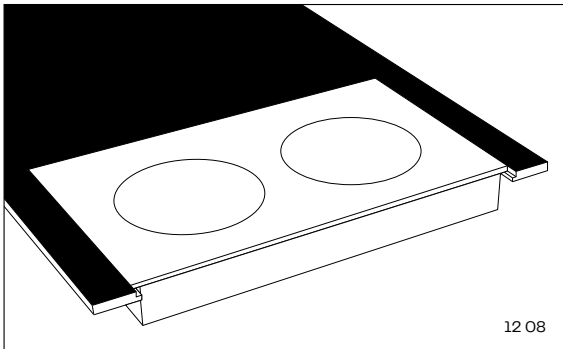

- 12 07 Kitchen
- 12 08 Glass Top Stoves
- 12 09 Panel fold
- 12 10 recessed sink
- 12 11 Panel fold
- 12 12 bottom mount sink
- 12 13 Adhesive surface sink

At least 6 mm panel thickness must remain.

Installation of recessed sink

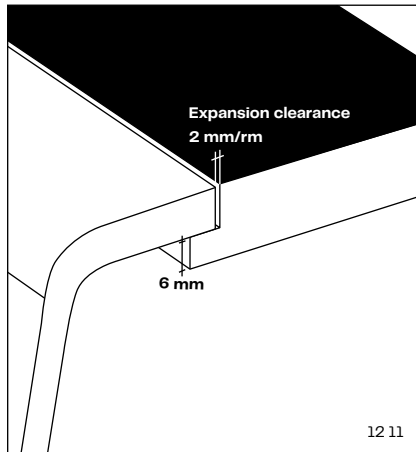
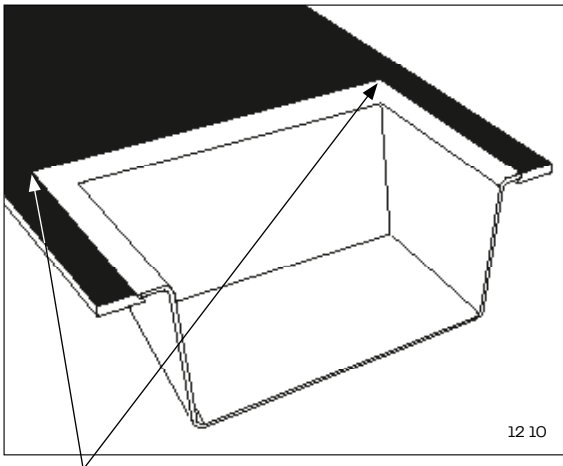

Always leave a radius of at least 5mm around inside corners.

At least 6 mm panel thickness must remain.

Installation of bottom mount sink

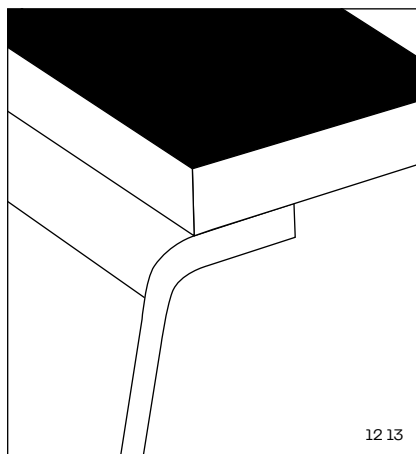
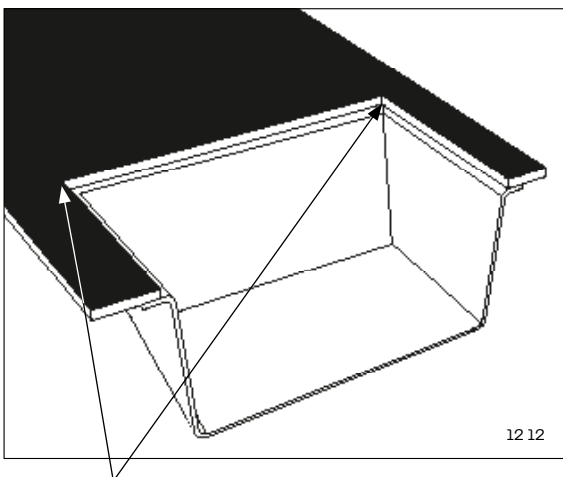

Always leave a radius of at least 5mm around inside corners.

13 Wash basins

“Hygiene is essential – so are the facilities that enable it.”

(Patricia Z., practice manager)





General notes

Max Compact Interior panels are particularly suitable for furniture construction, bathroom fittings, office furniture, shop fittings and design applications.

Depending on the use, these panels can be used in furniture construction using the standard adhesive systems to join or mount materials together or to clad a corresponding substructure.

Construction information

- Max Compact Interior panels shrink when releasing moisture and expand when absorbing moisture – take this into account during processing and construction.
- Structures made of metal change their dimensions with temperature differences, Compact panels with changing relative humidity – this can be contrary, so care must be taken to ensure sufficient expansion clearance. Rule of thumb for the amount of expansion clearance needed: 2 mm/rm.
- When connecting Max Compact Interior panels with each other (corner joints, stumps or bevel cuts), make sure that the grain direction is the same (vertical with vertical and horizontal with horizontal). Leftover panel pieces should always be marked with the production direction. Support corner joints with anchors, springs, special milling, etc.
- For high levels of moisture, a mechanical connection of joints is indispensable when combined with an elastic and watertight bonding adhesive system.
- Protect material from accumulating moisture – panel material must be allowed to dry.
- For use in wet rooms, a sufficient ventilation system in the room is important.
- Visible edges, or edges within reach must be beveled or at least sanded down using sandpaper to prevent injuries and damages to the material.
- Do not mill into the surface – this maintains cleanability.



13 01

Note:

Fundermax reserves the right to make changes in the interest of technical progress.

Installation possibilities for wash basins using Max Compact panels

The simple solution

Cutting out/screwing in an “insertable washbasin.”

Note:

Max Compact Interior panels with white core are not suitable for high traffic areas due to the increased visibility of soiling.

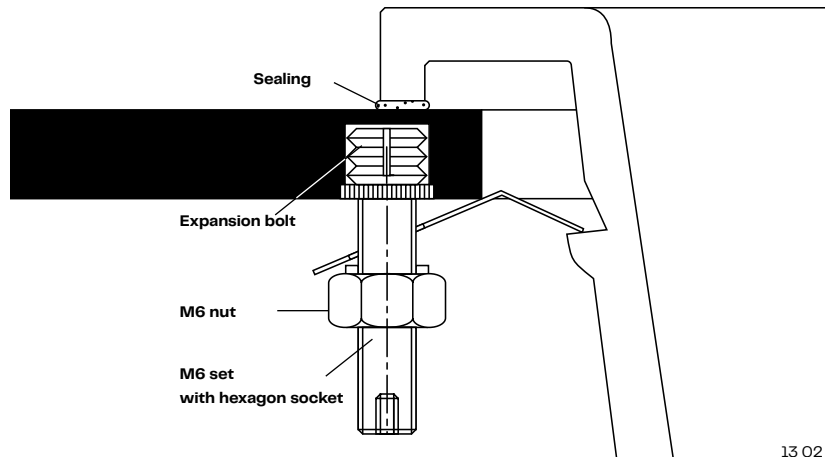

13 02

The rational solution

Milling Max Compact panels and unscrewing the built-in wash basin.

For high quantities of components, the milling can be done with a table router using template.

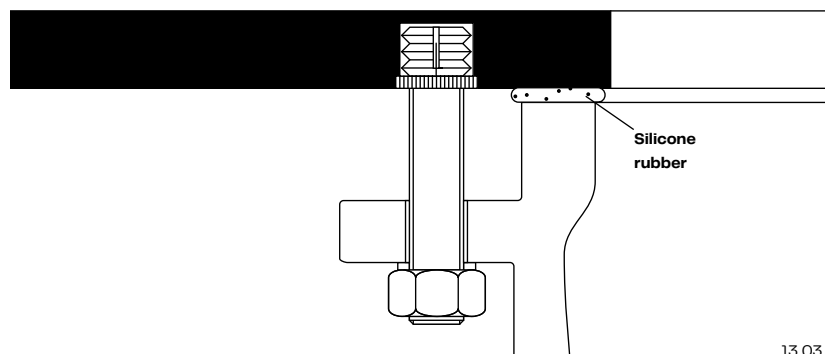

13 03

The elegant solution

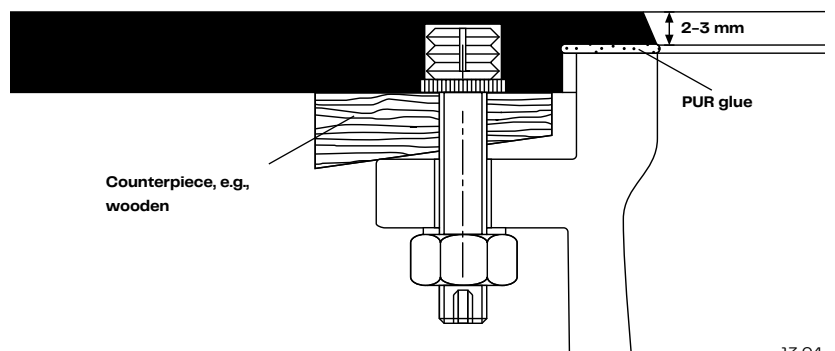

13 04

13 01 Bathroom

13 02 Insert wash basin

13 03 Built-in wash basin

13 04 Built-in wash basin, recessed

14 Railings

**“The task is to combine design
and safety.”**

(Matteo V., Architect)





General notes

Max Compact Interior panels can be mounted in different ways onto railings and balustrades. They can be screwed or riveted to a substructure or fastened using glass clamps.

Max Compact Interior panels shrink when releasing moisture and expand when absorbing moisture – take this into account during the processing and construction process. Structures made of metal change their dimensions with temperature differences, Compact panels with changing relative humidity – this can be contrary, so care must be taken to ensure sufficient expansion clearance. Rule of thumb for the amount of expansion clearance needed: 2 mm/rm.

Construction information

- Max Compact Interior panels should only be mounted as infill panels for supporting substructures.
- Protect material from accumulating moisture – panel material must be allowed to dry.
- When connecting Max Compact Interior panels to each other (corner joints butt or mitered), ensure that all parts to be connected are arranged in the same production direction (vertical with vertical and horizontal with horizontal). Leftover panel pieces should always be marked with the production direction.
- Protect substructure against corrosion/rotting.
- All edges within reach must be sanded, V-joints form between the panel joints.



14 01 Railing infill mechanically fastened

14 02 Minimum distances between perforations with fall protection

14 03 Staircase railing – hole milling

Railing fillings with hole patterns:

- The panel thickness is directly related to the mounting distance.
- The mounting brackets must comply with the static requirements and local building regulations. However, for perforated panels the distance between the brackets must be reduced by at least 20%.
- Holes or slots must be arranged in such a way that children can not use them for climbing. Holes should not be larger than 50 mm in diameter.
- For recesses, we recommend using thicker panels in accordance with fall protection standards.
- The webs between the holes or slots must be at least as wide as the diameter of the holes or slots. This also applies for distances from the edge.

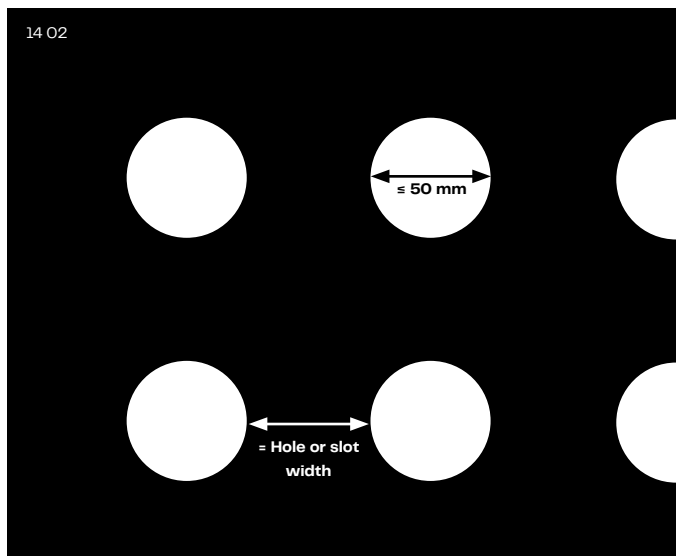

Perforation Guidelines Max Compact

Our general recommendations for perforating Fundermax Compact Panels:

- Distance from the edge to the panel to the first machined area minimum 60mm
- Distance between the perforations, minimum 30mm
- Spacing between holes should be at least 1.5X the diameter of the hole
- No 90 degree edges at any machined out areas A minimum radius of 5mm at every edge or corner
- Around the fixing points for rivets or screws you will need minimum a space of 40mm diameter without any material removed.
- All edges on perforations should have a chamfer of 1 or 2mm
- Over 20% perforation will decrease the stability of the panel and may require reduced fastening distances
- When possible, perforations should be kept to 30% or less open area
- All patterns must be approved by the Fundermax Machining Center
- All perforated Fundermax panels are subject to review and approval by the Project Engineer

We will gladly review your CAD drawings for any application when considering perforation. Our state of the art CNC Processing Center can make your vision into a reality!



Stairs in Germany | Product: Max Compact Interior
Decor: White #0085 FH | Photo Credit: Paul Masukowitz | Architect: Jörn Brenscheidt



Cinema in Russia | Product: Max Compact Interior | Photo Credit: Salavat Aliulov
Architect: Salavat Aliulov

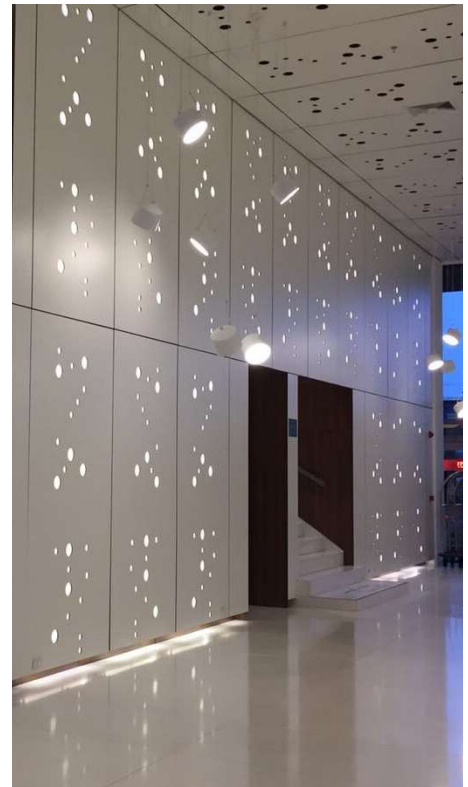

Hotel in Paraguay | Product: Max Compact Interior
Decor: White #0085 FH | Architect: Emprenurban

Fastening points

There should usually be three fastening points in every direction. Structural evidence must be shown. The stability of the railing is guaranteed by the processor.

Fundermax points out that this information relates to height distances and can only be used for flawless connections. Adequate screw and rivet dimensions must be adhered to.

Note:

In the Fundermax brochure “Technique Exterior” (www.fundermax.com – Downloads) we demonstrate different mounting possibilities for railings with Compact panels, which have all been tested and approved by the “ETB Guidelines for structural elements that protect against falls” (6.1.85).

Mounting distances for balcony screws

Max Compact panel thickness	AW	AS	E
8 mm	≤ 1000 mm	≤ 400 mm	20-200 mm
10 mm	≤ 1100 mm	≤ 500 mm	20.0-250 mm

Mounting distances for clamping brackets

Max Compact panel thickness	AW	AS	E
8 mm	≤ 950 mm	≤ 450 mm	20-160 mm
10 mm	≤ 1100 mm	≤ 500 mm	20-200 mm

Mounting distances for rivets

Max Compact panel thickness	AW	AS	E
8 mm	≤ 950 mm	≤ 350 mm	20-200 mm
10 mm	≤ 1000 mm	≤ 400 mm	20.0-250 mm

⊗ Fixed point

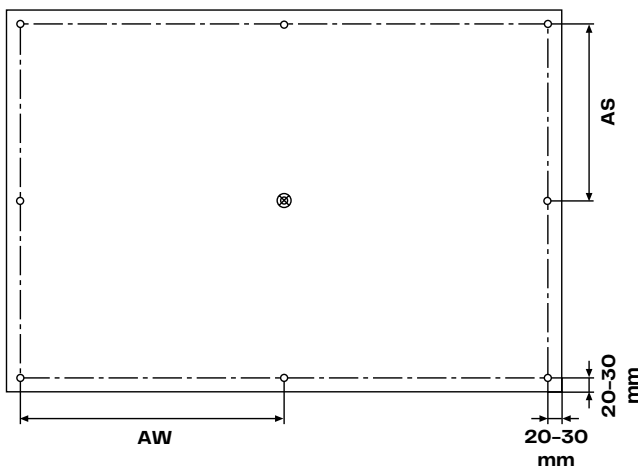

Mounting varieties

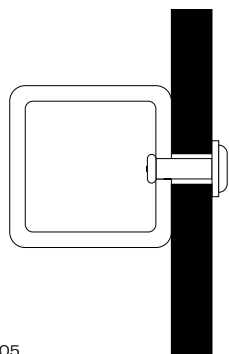

14 05

Direct fastening using blind rivets with flat round-head
5 x 21 mm stainless steel and rivet washers NR 8; inner diameter: 5.1 mm; set rivets with hinge tips.

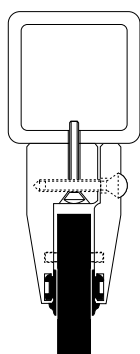

14 06

Mounting devices screwed to the railing tube
(e.g., Schüco, Alu-königstahl, Längle)

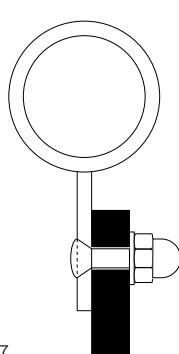

14 07

Welded steel handles with raised countersunk head screws
M6 x 20 DIN 964 and cap nut M6 DIN 1587 (stainless steel)

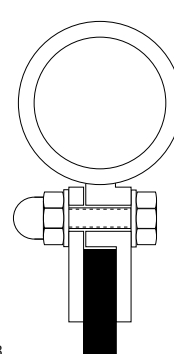

14 08

Welded steel handles with two clamping plates and hexagon bolts
M6 x 25 DIN 933, cap nut M6 DIN 1587 and sheets M6 DIN 121 A (stainless steel)

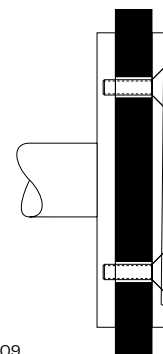

14 09

Fastening of Compact panels with pairs of circular plates (5 mm thick); the base plates are welded flush to aligned projections jutting from vertical rail stanchions. The cover plates are screwed with two stainless steel countersunk screws (M6 x 20 DIN 963) through the drill holes of the Compact panel (expansion clearance!) to the base plates.

14 04 Mounting distances

14 05 Blind rivet fastening

14 06 Glass clamp holder fastener

14 07 Lens countersunk head screw fastening

14 08 Clamp plates brackets

14 09 Mounting, base panel & cover plate

Suppliers/accessories

Touch Up Paints

North America

Konig North America, LLC
2800 Black Lake Place, Unit D
Philadelphia, PA 19154
Tel: (215) 426-6216 EXT 312
Fax: (215) 464-2144
www.konigtouchup.com

Fasteners (mechanical)

North America

SFS Group USA, Inc.
1045 Spring Street
Wyomissing PA 19610
(610) 376-5751
<https://us.sfs.com/>

Monarch Metal Fabrication

1700 Ocean Ave Ste 2
Ronkonkoma NY 11779
(631) 750 3000
<https://www.monarchmetal.com/>

Austria

EJOT AUSTRIA GmbH
Graz suburb 146
A-8570 Voitsberg
Tel: +43 (0)3142 27600-0
Fax: +43 (0)3142 27600-30
info@ejot.at
www.ejot.at

SFS Intec GmbH
Wiener Straße 29
A-2100 Korneuburg
Tel: +43 (0)2262 90500102
Fax: +43 (0)2262 90500930
www.sfsintec.biz

Germany

MBE GmbH
Siemensstraße 1
D-58706 Menden
Tel: +49 (0)2373 17430-0
Fax: +49 (0)2373 17430-11
www.mbe-gmbh.de

Fischerwerke – Arthur Fischer GmbH & Co. KG
Weinhalde 14-18
D-72178 Waldachtal
Tel: +49 (0)7443 120
Fax: +49 (0)7443 124222
www.fischer.de

Netherlands

Ipex Europe B. V.
Vonderweg 14
NL-7468 DC ENTER
Tel: +31 (0)547 384635
Fax: +31 (0)547 384637
www.ipex-group.com

Switzerland

SFS intec AG (Headquarters)
Rosenbergsaustasse 10
CH-9435 Heerbrugg
Tel: +41 (0)71 7276262
Fax: +41 (0)71 7275307
gmi.heerbrugg@sfsintec.biz
www.sfsintec.biz

Fastener (adhesive)

Austria

Fassadenklebetechnik Klug GmbH
Head office
Julius-Tandler-Platz 6/15
A-1090 Vienna
Tel: +43 (0)676 7271724
office@fassadenklebetechnik.at
www.fassadenklebetechnik.at

INNOTEC Industries
Vertriebsgesellschaft mbH
Floor 35
A-6322 Kirchbichl
Tel: +43 (0)5332 71138
Fax: +43 (0)5332 72891
www.innotec.at

PRO PART Handelsgesellschaft mbH
Lauchenholz 28
A-9122 St. Kanzian am Klopeinersee
Tel: +43 (0)4239 40300
Fax: +43 (0)4239 40300-20
www.fassaden-kleben.at

Germany

Walter Hallschmid GmbH & Co. KG
Wiesenstraße 1
D-94424 Arnsdorf
Tel: +49 (0)8723 96121
Fax: +49 (0)8723 96127
www.dichten-und-kleben.de

Switzerland

SIKA Chemie GmbH
Tüffenwies 16-22
CH-8048 Zürich
Tel: +41 (0)58 4364040
Fax: +41 (0)58 4364655
www.sika.ch

Disclaimer

The information made available in this document is exclusively for the purposes of general information. Not all of the systems mentioned and shown in this document are suitable or appropriate for all areas of application. All customers and third parties are obligated to inform themselves thoroughly about Fundermax products, including their suitability for certain purposes.

We explicitly recommend that you and other users of this document seek out independent expert advice on adherence to local planning and use requirements, applicable laws, regulations, standards, guidelines and testing standards. Fundermax accepts no liability in connection with the use of this document. Responsibility for correct and appropriate planning and workmanship lies exclusively with those planning or processing the materials.

All of our spoken and written statements, offers, bids, sales, shipments and/or contracts as well as all related activities are subject to the General Terms and Conditions of Sale of Fundermax GmbH in the currently valid version (see www.fundermax.com).

* Fundermax assumes no liability for products of the listed companies with regard to their quality and suitability for specific applications.

Fundermax GmbH

Klagenfurter Straße 87-89, A-9300 St. Veit/Glan
T: +43 (0)5 9494-0
F: +43 (0)5 9494-4200
office@fundermax.at
www.fundermax.com

Fundermax Deutschland GmbH

Mundenheimer Weg 2
67117 Limburgerhof, Germany
infoGermany@fundermax.biz
www.fundermax.de

Fundermax France S.a.r.l.

3 Cours Albert Thomas
69003 Lyon, France
Tel: +33 (0)4 78682831
infoFrance@fundermax.biz
www.fundermax.fr

Fundermax India Pvt. Ltd.

Sy. No. 7, Honnenahalli, Doddballapur Road,
Yelahanka Hobli, Bangalore – 560064, India
officeIndia@fundermax.biz
www.fundermax.in

Fundermax Italia s.r.l.

Viale Venezia 22
33052 Cervignano del Friuli, Italy
infoItaly@fundermax.biz
www.fundermax.it

Fundermax Polska Sp. z o.o.

ul. Rybitwy 12
30-722 Kraków, Poland
Tel: +48 (0)12 6534528
infoPoland@fundermax.biz

Fundermax Swiss AG

Industriestrasse 38
5314 Kleindöttingen, Switzerland
Tel: +41 (0)56 2688311
infoSwiss@fundermax.biz
www.fundermax.ch

Copyright

All texts, photos, graphics, audio and video files are subject to copyright and other laws protecting intellectual property and may not be duplicated, altered or used on other websites for purposes or business, etc.

Fundermax North America, Inc.

9401-P Southern Pine Blvd.
Charlotte, NC 28273, USA
Tel: +1 (980) 299 0035
Follow us: @fundermaxna
contactfna@fundermax.biz
www.fundermax.us

