

Max Compact Exterior Technical Details

North America Edition | March 2024

www.fundermax.us



For you to create

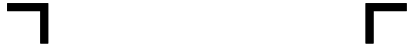

Fundermax



“Creativity needs to be outwardly appealing.”

(Hannes K., architect)



Contents

Products	4
Sustainability and the Environment	12
Cleaning	16
Processing Recommendations	18
Facades	30
Soffits	72
Outdoor Furniture	76
Balconies and Railings	80
Perforation Guidelines	92
Podio Balcony Floor Panels	96
Roof Coverings	106
Sun Protection	112
Suppliers and Components	116
Minimum Airflow Requirements	118

Notes

Current version of this brochure:
www.fundermax.us/brochures

The diagrams in this brochure are schematic representations and are not true to scale.

This issue replaces all previously published issues of Max Compact Exterior Technical Details from Fundermax.

If you have any questions that this brochure does not answer, please contact our sales team or application engineers at support@fundermax.biz. We will be happy to help you.

Fundermax

From furniture and facades to interior design, Fundermax is at the interface of ideas and materials. Today the company – which has a proud history spanning 130 years – stands as a global market leader and producer of high quality materials using wood and laminates. Our lasting success has been based on high quality, imaginative design, diversity and sustainable production. Our products are “Made in Austria” and exude a love for the natural resources of wood, creativity and inventiveness.

- modern production facilities in Austria and Norway
- approx. 1,500 employees
- annual turnover of €500 million
- part of Constantia Industries AG
- The Austrian Excellence Award (2018)

1 Products

“Only good ideas and good products are really durable.”

(Isabelle S., project manager)



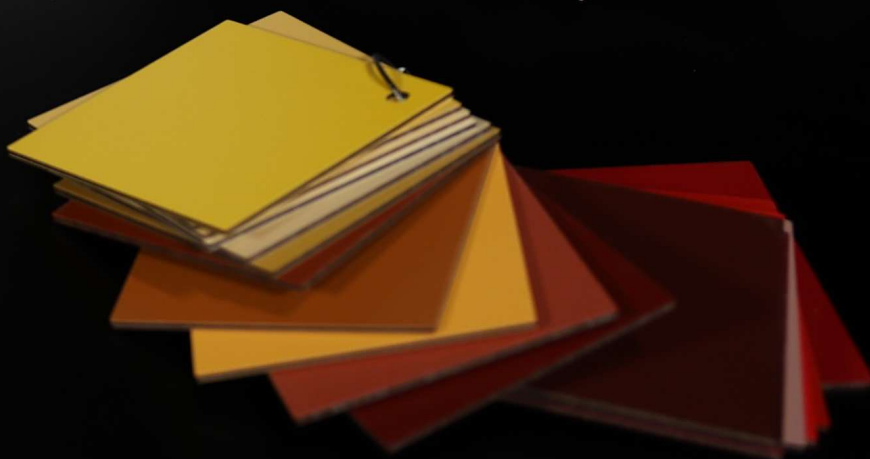
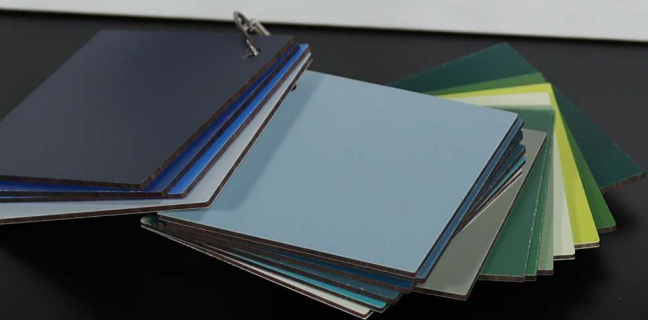

Max Compact Exterior

These panels are thermoset high-pressure laminates (HPL) that meet the requirements of EN 438-6, type EDF, and are produced in laminate compactors at a high temperature and pressure. Double hardened acrylic polyurethane resin ensures highly effective weather protection—ideal for long-lasting facade cladding.

Properties*

- double hardened
- suitable for all outdoor applications
- weatherproof (EN ISO 4892-2)
- lightfast (EN ISO 4892-3)
- bending resistant (EN ISO 178)
- impact resistant (EN ISO 178)
- scratch resistant
- solvent resistant
- hail resistant
- frost and heat resistant
- continuous temperature load -80°C to $+80^{\circ}\text{C}$
- easy to install and clean
- decorative

* Standard and actual values: www.fundermax.com

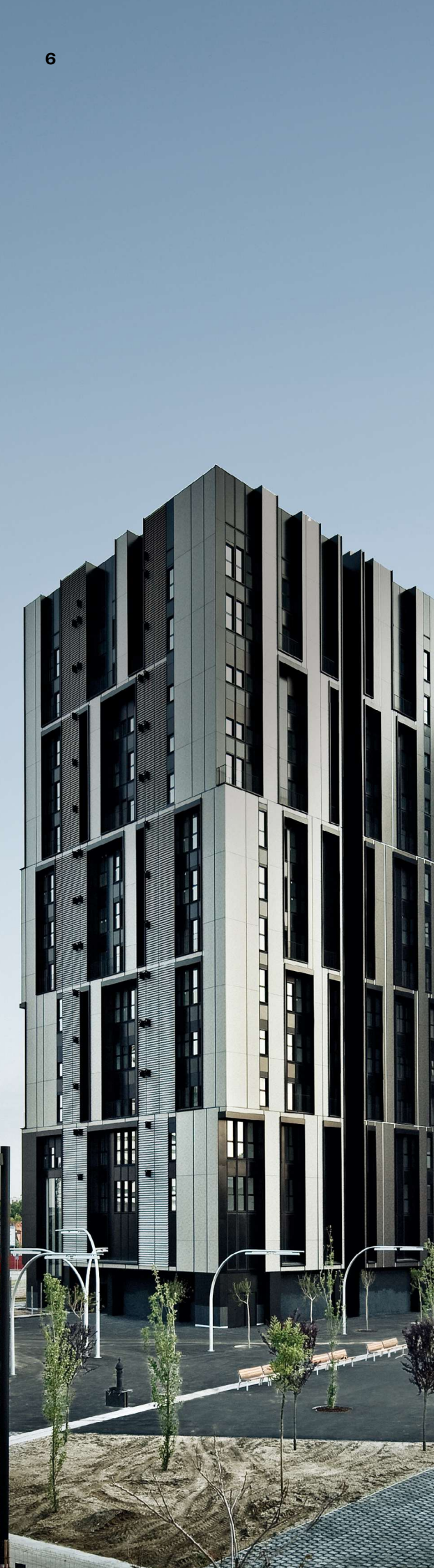

Designs

Max Compact Exterior F-Quality:

These panels come with decorative laminate on both sides, a flame-retardant core, and lightfast and weather-proof surfaces as standard (Fire Test EN 13501-1, B-s2, d0).

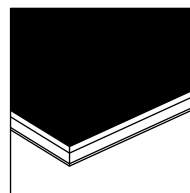

Composite elements:

To make composite elements, F-Quality panels can also be supplied with one smooth side.

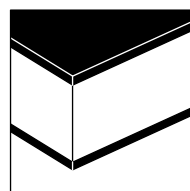

Max Compact Exterior elements:

Fundermax offers panel cutting and CNC machining— from drilling simple holes for attaching facade panels to complex milling for balcony components.

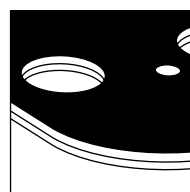

Professional Advice

Our services are designed to help you use our products more effectively. For example, you can benefit from free architectural advice and our extensive range of system solutions. We can also help if you have any questions about the information in this brochure or about decorative panels and technology.

Max Compact Exterior F-Quality

Fundermax panels feature thermoset high-pressure laminates (HPL) that meet the requirements of EN 438-6, type EDF, with the most effective weather protection thanks to double hardened acrylic polyurethane resin.

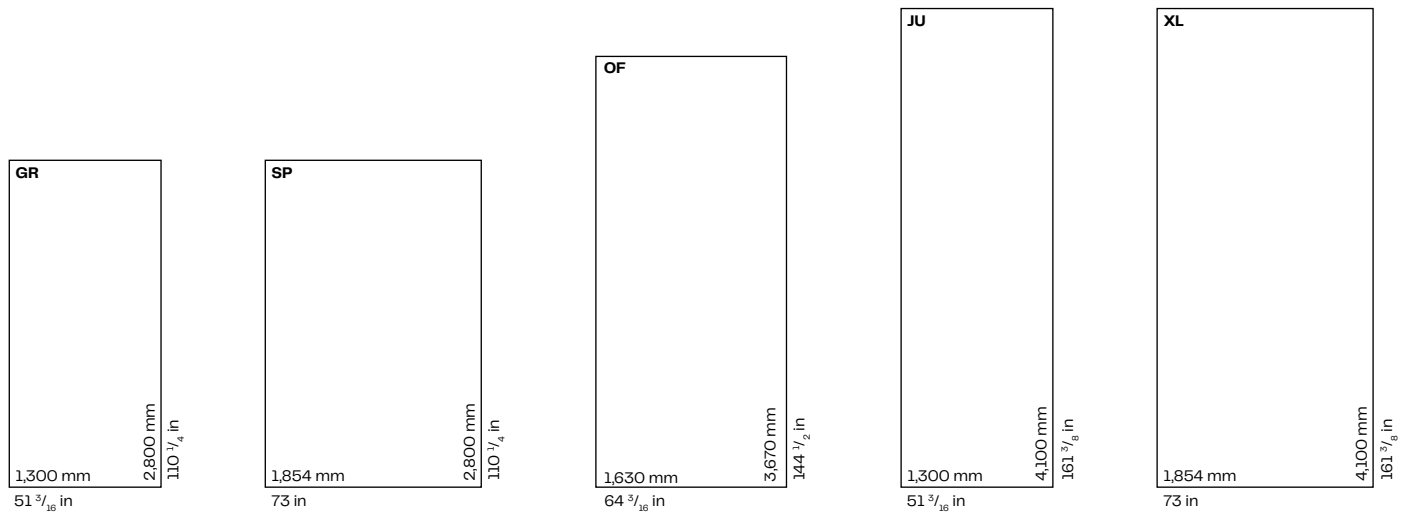

Surfaces

- NT (Standard)
- NH (Hexa)/NT (only for XL and GR sizes and in 2,050 x 1,854 mm)
- NG* (Gloss)/NG (Gloss) (only for JU size)
- NY (Sky)/NT (only for JU size, thicknesses of 6 and 8 mm, limited range of decorative finishes)
- NP (Paragon)/NT

Sizes **

- 110 ¹/₄ x 51 ³/₁₆ in = 39.18 ft²
• 2800 x 1300 mm = 3.65 m²
- 161 ³/₈ x 51 ³/₁₆ in = 57.37 ft²
• 4100 x 1300 mm = 5.33 m²
- 144 ¹/₂ x 64 ³/₁₆ in = 64.39 ft²
• 3670 x 1630 mm = 5.98 m²
- 110 ¹/₄ x 73 in = 55.88 ft²
• 2800 x 1854 mm = 5.19 m²
- 161 ³/₈ x 73 in = 81.82 ft²
• 4100 x 1854 mm = 7.60 m²

* Fractions are approximate due to imperial conversions.

Thicknesses

Panels with double-sided decor:

Thickness	Tolerance (EN 438-6, 5.3)
• 2.0–2.9 mm	±0.2 mm
• 3.0–4.9 mm	±0.3 mm
• 5.0–7.9 mm	±0.4 mm
• 8.0–11.9 mm	±0.5 mm
• 12.0–13.0 mm	±0.6 mm

Panels with the Hexa surface:

Thickness	Tolerance (EN 438-6, 5.3)
• 6.0–7.9 mm	±0.4 mm
• 8.0–11.9 mm	±0.5 mm
• 12.0–15.9 mm	±0.6 mm
• 16.0–20.0 mm	±0.7 mm

Panels with smooth reverse side (for symmetrical sandwich elements):

Thickness	Tolerance (EN 438-6, 5.3)
• 2.0–2.9 mm	±0.2 mm
• 3.0–4.0 mm	±0.3 mm

Core

- F-Quality
- Flame retardant
- Brown color

1 01 Composition of Max Compact Exterior panels

1 01

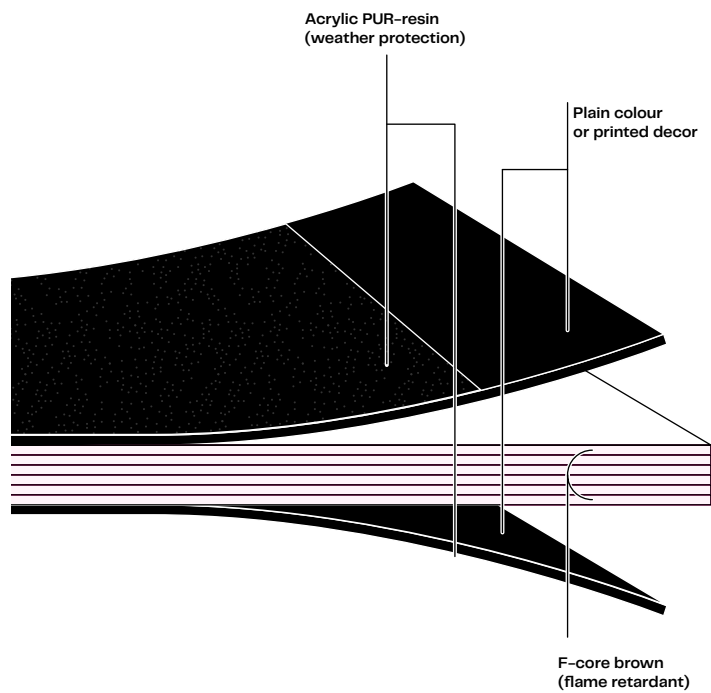

Tip

For a consistently light design for balcony interiors, Max Compact Exterior panels can also be made with a white (reverse) side (0890 NT – Balkonweiss). The combination of different decorative laminates means the specified mounting distances should be reduced by at least 15%.

* For the best possible facade cladding look, installation on an aluminum substructure is recommended. Timber is advised against, as an uneven surface can lead to a wavy appearance.

** Panel sizes with tolerances of +10.0–0.0 mm (EN 438–6, 5.3) are standard sizes—if absolute size and angle precision is required, cutting around all sides is recommended. Depending on the cut, the net measurement reduces by approx. 10.0 mm.

Max Compact Exterior—Physical Data and Approvals

Properties	Testing methods	Assessment	Standard value ¹⁾	Typical value ²⁾
Lightfastness and weather resistance (NT)				
Resistance to artificial weathering*	EN 438-2:2016, Section 29, 3,000 h	Contrast: Gray scale Appearance: Degree	Contrast: ≥ 3 Appearance: ≥ 4	Contrast: 4–5 Appearance: 5
Resistance to UV rays*	EN 438-2:2016, Section 28	Contrast: Gray scale Appearance: Degree	Contrast: ≥ 3 Appearance: ≥ 4	Contrast: 4–5 Appearance: 5
Properties				
Mechanical properties				
Bulk density	DIN 52328 / EN ISO 1183	g/cm ³	≥ 1.35	1.44
Flexural strength	EN ISO 178	MPa	≥ 80	Crosswise: 105 Lengthwise: 170
E-modulus	EN ISO 178	MPa	$\geq 9,000$	Crosswise: 11,000 Lengthwise: 16,000
Tensile strength	EN ISO 527-2	MPa	-	Crosswise: 95 Lengthwise: 140
Resistance to impact with a large ball	EN 438-2:2016, Section 21	mm	≤ 10	5–6
Thermal properties				
Resistance to moisture	EN 438-2:2016, Section 15	%	Mass increase: ≤ 8	2
Dimensional tolerance at high temperature	EN 438-2:2016, Section 17	%	Lengthwise: ≤ 0.30 Crosswise: ≤ 0.60	Lengthwise: 0.08 Crosswise: 0.16
Coefficient of thermal expansion	DIN 52328	1/K		18 x 10 ⁻⁶
Thermal conductivity		W/mK		0.3
Resistance to vapor diffusion				approx. 17,200 μ

Max Exterior Fire Testing/Code Compliance Data– USA/Canada

Testing Method	Description	Results
USA		
ASTM E84	Standard Test Method for Surface Burning Characteristics of Building Materials	Class A
ASTM D1929	Standard Test Method for Determining Ignition Temperature of Plastics	Pass (Self Ignition Temp. > 650 Degrees Celsius)
NFPA268	Standard Test Method for Determining Ignitability of Exterior Wall Assemblies Using a Radiant Heat Energy Source	Pass
NFPA285	Standard Fire Test Method for Evaluation of Fire Propagation Characteristics of Exterior Wall Assemblies Containing Combustible Components	Pass (Assembly Test – see https://specdirect.intertek.com/controls/SDDocumentViewer.aspx?ccrr=C0527 or contact us for details)
ICC AC92	(tests below)	Pass (Tests Below)
ASTM D1037	Standard Test Methods for Evaluating Properties of Wood-Base Fiber and Particle Panel Materials	Pass
ASTM C297	Standard Test Method for Flatwise Tensile Strength of Sandwich Construction	Pass
ASTM D2247	Standard Practice for Testing Water Resistance of Coatings in 100% Relative Humidity.	Pass
ASTM B117	Practice for Operating Salt Spray Fog Apparatus	Pass
ASTM G155	Standard Practice for Operating Xenon Light Arc Apparatus for Exposure of Non-Metallic Materials	Pass
Canada		
ULC S102	Standard Method of Test for Surface Burning Characteristics of Building Materials and Assemblies	Class A
ULC S134	Standard Method of Fire Test of Exterior Wall Assemblies	Pass (Assembly Test– contact us for details)

Max Exterior Installations of 8 and 10mm Exposed Fastening, 8mm Modulo, and 10mm Concealed Fastening are 2021 IBC Code Compliant (including NFPA285-2019 Edition) when installed per the assemblies listed in our Intertek Code Compliance Research Report: <https://specdirect.intertek.com/controls/SDDocumentViewer.aspx?ccrr=C0527>

1) In accordance with EN 438-6

2) Typical values are given as examples only and cannot be used for any liability on the part of Fundermax (they are not confirmed, guaranteed values). Fundermax only guarantees compliance with standard values.

* Custom decorative printing: Artificial weathering EN ISO 4892-2: 3,000 h; Assessed based on the gray scale EN 20105-A02: 3

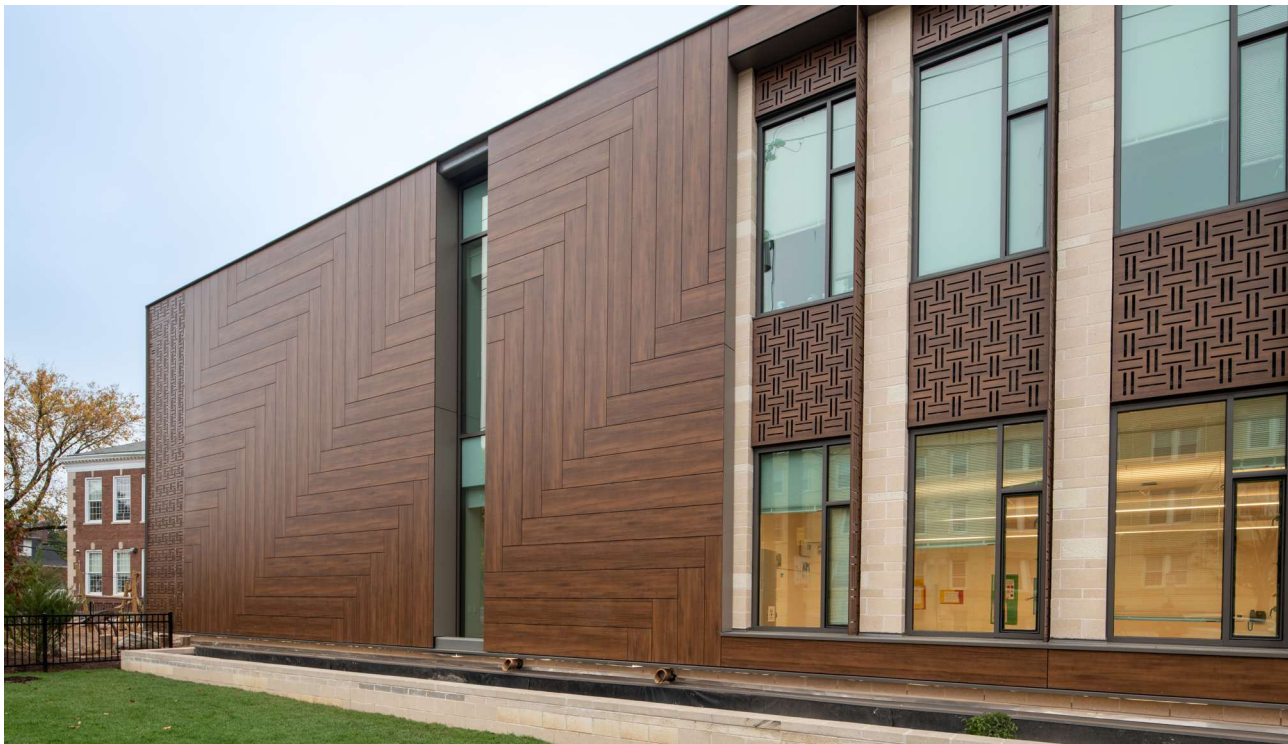

For the NT surface, a gloss level tolerance of ± 5 GE is measured at 60° . With regard to color tolerance, the ÖFHF Tolerances data sheet applies (version dated 16 January 2017; www.oefhf.at).

Other and up-to-date tests and approvals can be found in the Downloads section at www.fundermax.com.

Legal notes:

Please take into account any currently valid building regulations; we accept no liability in this regard.

Please check whether your construction project complies with the requirements to effectively restrict the spread of fire (e.g., OIB-RL 2, German draft administrative regulation for technical building regulations (MVV TB), etc.). This brochure is intended for specialists who are trusted to adhere to the relevant standards, technical regulations, legal requirements, and guidelines relating to building products.

The rules have been painstakingly revised. However, we would like to point out that responsibility for proper planning lies with the planner, and responsibility for correct installation lies with the contractor.

2 Sustainability and the Environment

**“I want my work to leave a mark—
but it should be sustainable.”**

(Henrik T., entrepreneur)





Sustainability at the Company

Fundermax is a specialist in processing renewable raw materials—and has been for over 130 years. This involves closed production cycles, material remnants being returned to the production process, and energy recovery in green power district heating plants. This allows Fundermax to generate district heating for a total of 10,000 households as well as reduce CO₂ emissions by 30% since 2005.



Quality Management

The production facilities and processes comply with internationally recognized standards (ISO 9001, ISO 14001, ISO 50001, ISO 45001). Fundermax’s process of procuring raw and primary materials also follows current standards such as FSC® C101966 and PEFC™ (details: www.fundermax.com).

Sustainable Production

Max Compact Exterior panels consist of natural fiber panels (about 65% of the total weight) and are made mainly of wood, which is processed into kraft paper. This wood is a by-product from lumber production or in sawmills. The raw materials come from suppliers certified to the FSC® C101966 and PEFC™ standards, which guarantee sustainable forest management.

The kraft paper is impregnated with synthetic resins in impregnation plants, then dried and pressed into panels at a high pressure and temperature. They do not contain any organic halogen compounds, asbestos, wood preservatives (fungicides, pesticides, etc.), sulfur, mercury, or cadmium.

The exhaust air extracted during drying is treated using regenerative thermal oxidation. The heat generated from this is returned to the process, saving around 10,000 tons of CO₂ annually. This exhaust air treatment has also received the “klimaaktiv” award from the Austria Energy Agency and the Federal Ministry for the Environment.

Waste Disposal

When Max Compact Exterior panels are cut and milled, they produce chips. These can be disposed of thermally, in modern heating systems, without emitting hydrochloric acid, organic chlorine compounds, or dioxins. Max Compact Exterior decomposes into nothing but carbon dioxide, nitrogen, water, and ash. The resulting energy is used for district heating, for example. Disposal at commercial landfills is no problem either—country-specific laws and regulations apply.

Fundermax can potentially contribute to LEED in several categories with our EPD, HPD, FSC, and Greenguard Certificates.

SUSTAINABILITY COMPARISON CHART

F	Max Exterior	Max Interior	Max Interior F Quality
	Max Authentic	Max Interior Plus Max Resistance ²	Max Interior Plus F Quality
FSC Certified*	✓	✓	✓
EPD	✓	✓	✓
HPD	✓	✓	✓
Greenguard		✓	✓
Greenguard Gold		✓	✓
ISO9001	✓	✓	✓
ISO14001	✓	✓	✓
ISO45001	✓	✓	✓
ISO50001	✓	✓	✓
No Added Urea Formaldehyde	✓	✓	✓
100% Recycled Paper Core**		✓	

* - 65% Kraft Paper by Weight

** - 65% of Panel

3 Cleaning

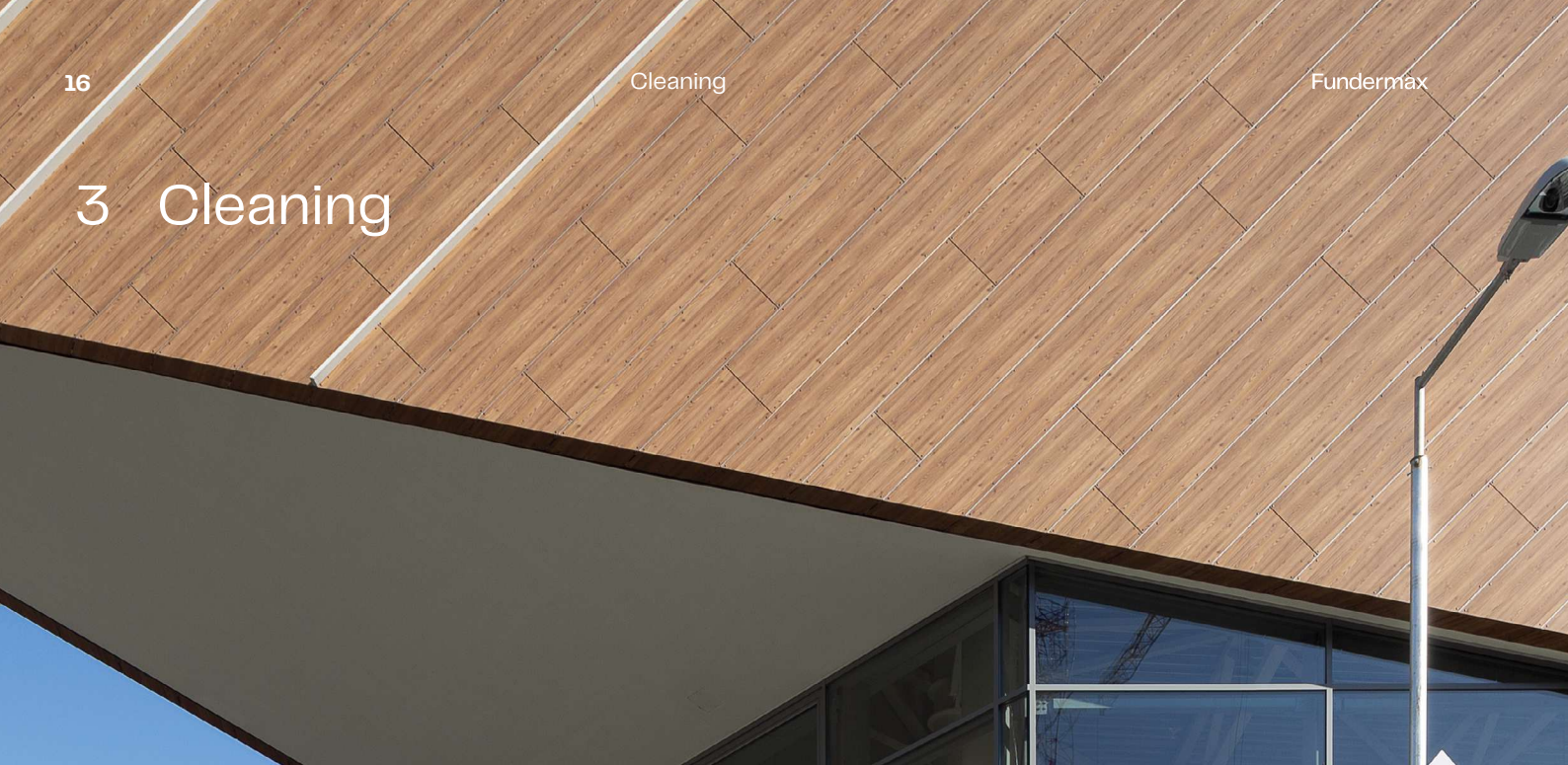

“Flawlessness is the most beautiful goal.”

(Matteo V., architect)



Cleaning Process for Max Compact Exterior

For unknown stains:

Perform basic cleaning and, if necessary, cleaning steps 1 to 6 in order until the desired result is achieved. When cleaning with solvents, observe accident prevention regulations. No open flames!

Basic cleaning:

Clean surface just with hot water and a soft sponge, cloth, or brush (e.g., nylon brush)—DO NOT scrub!

Step 1:

Clean the surface with clean, hot water using a sponge (don't use the rough side), cloth, or soft brush—DO NOT scrub!

Step 2:

If that doesn't remove the stain, use a cleaning product that doesn't contain any abrasive ingredients (e.g., dishwashing liquid, glass cleaner). Carry out final cleaning.

Step 3:

If the stain persists, a soap-based solution (1:3) can be used. Give it more time to take effect depending on the degree of soiling. Carry out final cleaning.

Step 4:

Same as step 1, but using organic solvents (e.g., acetone, alcohol, nitro thinner, turpentine). Remove deeper stains mechanically. Caution: Avoid scratches by using a plastic or wooden spatula. Carry out final cleaning.

Step 5:

For adhesive, varnish, sealant, and silicone residue: Wipe the surface with a dry soft cloth or sponge. If the stain persists, use silicone remover or a cleaning product recommended by the adhesive manufacturer. Please note: Hardened 2-part adhesive, 2-part varnish, 2-part foam, or 2-part sealant CANNOT be removed!

Step 6:

In the case of extremely persistent lime contamination, acidic cleaning agents (e.g., 10% acetic or citric acid) can also be used. Carry out final cleaning.

Final cleaning:

Remove all traces of the cleaning product to prevent smears. Lastly, rinse with clean water. Dry the surface with an absorbent cloth or paper towel.

4 Processing Recommendations

**“Good products call for
good treatment.”**

(Jonas G., contractor)



Guidelines for Handling Max Compact Exterior

- 4 01 Handling Max Compact Exterior panels
- 4 02 Stacking and storing Max Compact Exterior panels
- 4 03 Short-term temporary storage
- 4 04 Storage of pre-assembled elements

Transport and Handling

Handle with care! Despite the surface hardness and transport protection film, the stack weight can cause damage. Therefore, it is important to avoid getting dirt or dust between the panels.

Secure the panels to prevent slipping during transport and lift them during loading and unloading—do not pull or push them over the edge (see Fig. 4 01)!

Always remove transport protection film from both sides at the same time. Leaving the protection film on one side may cause the panel to warp. Increased adhesion of the film may occur after storage, requiring more force to remove it. This does not affect the quality of the product and is not a reason for complaint. Do not expose the film to direct sunlight or heat.

Installation

Appropriate protective equipment (protective gloves, helmet, etc.) must be used while handling and installing the facade panels. Gloves must be clean and free from abrasive anti-slip coatings to avoid staining or damaging the surfaces. Any body oils or sunscreen should be cleaned off immediately.

Storage and Air Conditioning

Max Compact Exterior panels must be left in their original packaging. They should be stacked horizontally on a flat, stable, and padded surface. If necessary, they can be stored for a short time as shown in Fig. 4 03. The panels must lie completely flat. After removal, the original packaging should be closed again.

Cover plates must always be left on the stack (see Fig. 4 02). The top cover should be weighted down—this also applies to stacks with cut panels.

Incorrect storage will cause permanent deformation of the panels. Max Compact Exterior panels should be stored in enclosed spaces, under normal climatic conditions (15°C to 25°C, with relative humidity at 40–60%). Avoid exposing the two surfaces to different climatic conditions.

In the case of pre-fitted fastening elements, make sure the climatic influence is the same from all sides. Use intermediate layers of wood or plastic (see Fig. 4 04).

Final Cleaning

Foreign substances (e.g., drilling and machine oils, greases, adhesive residues, etc.) that soil the surface of the Max Compact Exterior panels during storage, installation, and use must be removed immediately without leaving any residue. We recommend using oil-free sunscreen (e.g., Physioderm Physio UV 50 Spray), since it is often not possible to remove conventional sunscreens completely. If these recommendations are not observed, we cannot accept responsibility for any complaints regarding color, gloss, or surface. For the best possible appearance, regular cleaning is recommended. Please also note our cleaning steps on page 17.

4 01

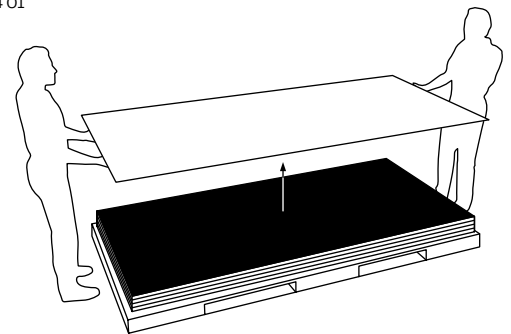

4 02

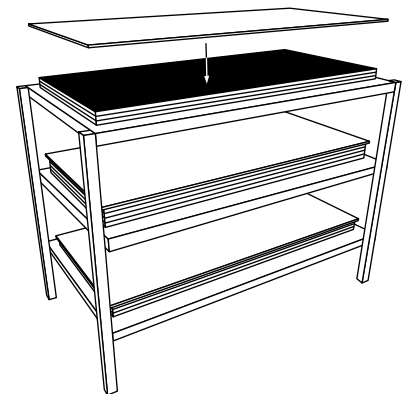

4 03

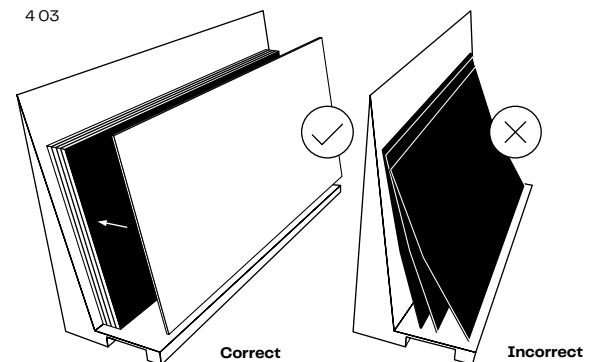

4 04

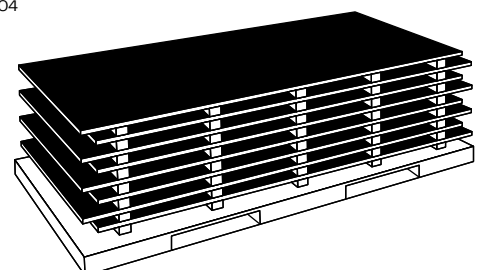

Working with Max Compact Exterior

General

Panel surfaces made out of double hardened acrylic polyurethane resin are extremely durable. The processing properties are similar to those for processing hardwood. Tools with tungsten carbide blades are essential. Use tools equipped with diamond tips (PCD) to make them last. To prevent chipping, splintering, and flaking of the decorative side, using sharp-bladed tools that function smoothly is a must. To protect the surface and prevent chips from becoming lodged, machine tables should be smooth and have as few joints as possible. This also applies to workbenches and using handheld machines.

Safety Measures

This is simply a list of recommended personal protective equipment (PPE). The protective equipment required to ensure the safety of the respective activity must be used (work clothes, safety boots, hairnets, etc.).



Gloves:

Non-beveled cutting edges are sharp. You should use protection category II gloves with at least cut resistance 2.



Dust protection:

Processing these panels can create dust. Adequate respiratory protection (e.g., disposable fine dust mask) must be used.



Safety glasses:

When working with Max Compact Exterior panels, as with other wood-based materials, use eye protection that is as tightly sealed as possible.



Hearing protection:

The sound level can rise above 80 dB(A) during mechanical processing. Please always make sure you have adequate hearing protection!

EN 388		Mechanical risks	
The higher the number, the better the test result.			
4	1	2	1
Test criterion		Possible ratings	
Abrasion resistance		0-4	
Cut resistance		0-5	
Tear strength		0-4	
Puncture resistance		0-4	

General Processing Guidelines

When working with Max Compact Exterior panels, keep in mind the ratio between the number of teeth (z), the cutting speed (v_c), and the feed rate (v_f).

	vc m/s	fz mm
Sawing	40.0–60.0	0.02–0.1
Milling	30.0–50.0	0.3–0.5
Drilling	0.5–2.0	0.1–0.6

Calculating the Cutting Speed

$$v_c = D \cdot \pi \cdot n / 60$$

v_c – cutting speed [m/s]

D – tool diameter [m]

n – tool speed [min⁻¹]

Calculating the Feed Rate

$$v_f = f_z \cdot n \cdot z / 1,000$$

v_f – feed rate [m/min]

f_z – tooth feed

n – tool speed [min⁻¹]

z – number of teeth

Cutting Material

Tools with tungsten carbide blades (HW – Leitz) can be used. Using tools with polycrystalline diamond (PCD) blades is recommended to extend their service life.

General Notes

If chips are not regularly removed, this can quickly lead to the blade becoming damaged. The motor power required increases and the service life of the tool is shortened. If the shavings are too small, the tool will scrape and quickly become dull. That means it will have a shorter service life.

For single cuts, prevent the panel from vibrating by working with used panels. The stack height depends on the machine power.

All Fundermax panel leading edges should be beveled 1 or 2mm as untreated 90 degree corners are sharp and susceptible to chipping.

Tooth Shapes

TR/TR (trapezoid tooth/trapezoid tooth):

For cutting hard, abrasive laminates

HZ/DZ (concave tooth/pointed tooth):

For very good cutting and edge quality at the top and at the bottom on machines without a scoring unit

FZ/TR (flat tooth/trapezoid tooth):

For working with Max Compact Exterior panels

WZ/FA (variable tooth with bevel):

Alternative to flat tooth/trapezoid tooth shape

HZ/FA (concave tooth with bevel):

Application similar to HZ/DZ, but with longer tool life on machines without a scoring unit

- 4 05 TR/TR
- 4 06 HZ/DZ
- 4 07 FZ/TR
- 4 08 WZ/FA
- 4 09 HZ/FA

4 05

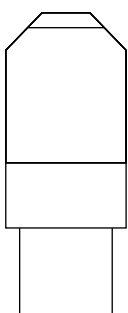

4 06

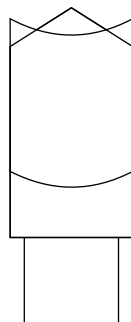

4 07

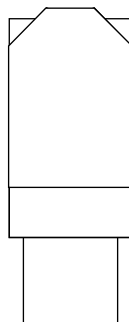

4 08

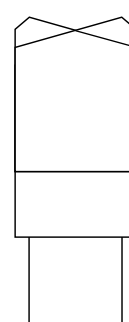

4 09

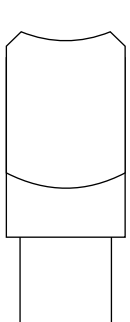

Cutting

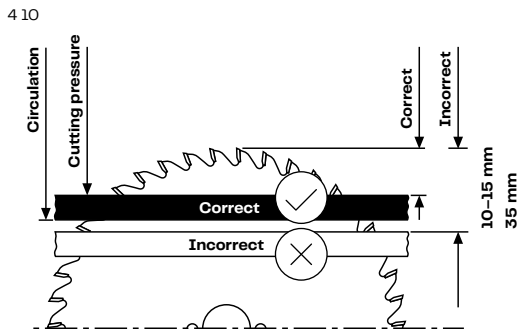

Vertical Panel Splitting, Table, and Sliding Table Saws without Scoring Unit

For circular saw blades with positive rake angle and saw shaft under the workpiece. Due to the positive rake angle, the cutting pressure takes effect using the stable table support (see Fig. 4 10).

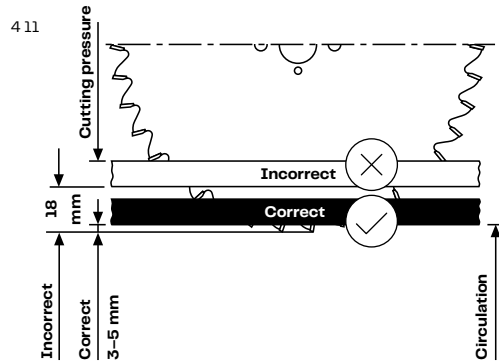

For circular saw blades with negative rake angle and saw shaft above the workpiece. Due to the negative rake angle, the cutting pressure takes effect using the stable table support (see Fig. 4 11).

Adjustment:

- Visible side up
- Very narrow saw guide
- Smooth alignment of the Max Compact Exterior panels on the workbench with the saw blade
- Correct blade protrusion

Depending on the blade protrusion, the entry and exit angles will change and thus the quality of the cutting edge. Upper cutting edge unclear: Raise the saw blade. Unclean cut on the underside: Lower the saw blade. This is how to find the most favorable height setting.

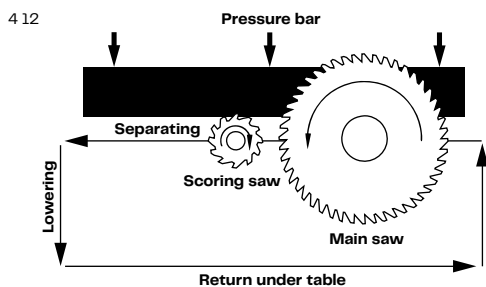

Sliding Table Saws and Panel Splitting Machines with Scoring Units and Pressure Bars

Scoring circular saw blades:

For good cutting edge quality on the tooth exit side, a scoring unit is recommended. Set the cutting width of the scoring circular saw blade to be slightly larger than that of the main circular saw blade so that the exiting tooth of the main saw no longer touches the cutting edge. Safe, flat support of the workpieces is only guaranteed with a pressure device. Use split scoring circular saw blades for table and sliding table saws. Panel splitting machine with scoring unit and pressure device. Operating diagram of the conical scoring circular saw blade. For maintenance of the tools (always in sets), the cutting widths (SB) must be aligned with one another.

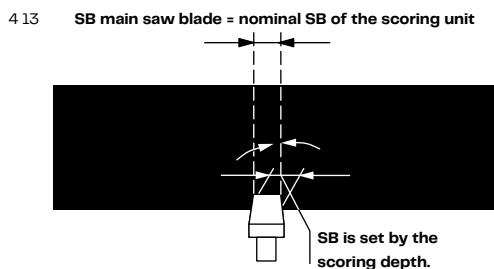

Cutting with Handheld Tools

Finely toothed hand saws are suitable for individual cuts. Slightly slanted teeth are preferable. Saw from the surface of the panel, and pass through at an angle (approx. 30°).

For straight cuts with handheld circular saws, use a stop bar or guide rail. Use tungsten carbide-tipped saw blades. The sawing is carried out from the underside of the panel, with the following tooth shapes:

- WZ (variable tooth) for coarse cuts
- FZ/TR (flat tooth/trapezoid tooth) for clean cuts of Max Compact Exterior and panels glued on both sides

For field cuts:

- 7 1/4" blade, 40 tooth
- 10" blade, 64 tooth

All Fundermax panel leading edges should be beveled 1 or 2mm as untreated 90 degree corners are sharp and susceptible to chipping.

Milling—Edge Processing

Edge Processing by Hand

Files are suitable for edge processing. The filing direction goes from the decorative side toward the core. Fine files, plane files, sandpaper (100–150 grain), or scrapers are suitable for smoothing edges.

Edge Processing with Handheld Machines

To mill bevels, use electric hand planes with a bevel or miter groove. Hand routers are used for special tasks (e.g., recesses for wash basins, trax couplings, etc.) using tungsten carbide tools. To protect the Max Compact Exterior surface, cover the supporting surface of the hand router with parts of a different panel, for example. Don't use felt! Carefully remove milling shavings.

Milling tool diameter: 10.0–25.0 mm

Cutting speed v_c : 30.0–50.0 m/sec

We recommend using tungsten carbide-tipped milling cutters with indexable inserts. For better tool utilization, height-adjustable milling tools are preferable. Sharp edges are smoothed afterwards.

4 10 Circular saw blades with positive rake angle and saw shaft under the workpiece

4 11 Circular saw blades with negative rake angle and saw shaft above the workpiece

4 12 Sliding table saw with scoring unit

4 13 Operating diagram

Drilling

Solid carbide twist (VHW) or dowel drill bits are used for drilling. In machining centers, the use of the main spindle instead of the drilling beams at an rpm of 2,000–4,000 min⁻¹ and a feed rate of 1.5–3.0 m/min is recommended. Select the exit speed of the drill so that the surface is not damaged. Shortly before the drill exits the workpiece in full diameter, the feed rate must be reduced by 50%. When drilling through-holes, the counter-pressure should be built up using hardwood or equivalent material to prevent the surface breaking off.

Note for blind holes perpendicular to the panel plane:

- Pilot hole diameter (D) = Screw diameter minus approx. 1 channel depth
- Drilling depth (a) = Panel thickness minus 1.0–1.5 mm
- Screw-in depth = drilling depth minus 1.0 mm

Note for blind holes parallel to the panel plane:

- The residual thickness (b) of the Max Compact Exterior panel must be at least 3.0 mm.
- Select the diameter of holes parallel to the panel plane so that the panel does not split when screwing in the screws.
- For screwing in parallel to the panel plane, metal sheet and chip board screws are suitable.
- For stability: 25.0 mm minimum screw depth

Twist drills with a point angle of $\leq 90^\circ$ are especially suited to Max Compact Exterior panels. They have a large pitch with a large chip space. The steep tip means they are also suitable for drilling through-holes. They cut cleanly through the back of the material.

Field Drilling:

- Fixed Points: 6mm
- Sliding Points: 8mm for panels up to 9' or 9.5mm for panels 9' and larger

* For field drilling of holes, brad point or spade bits are most efficient.

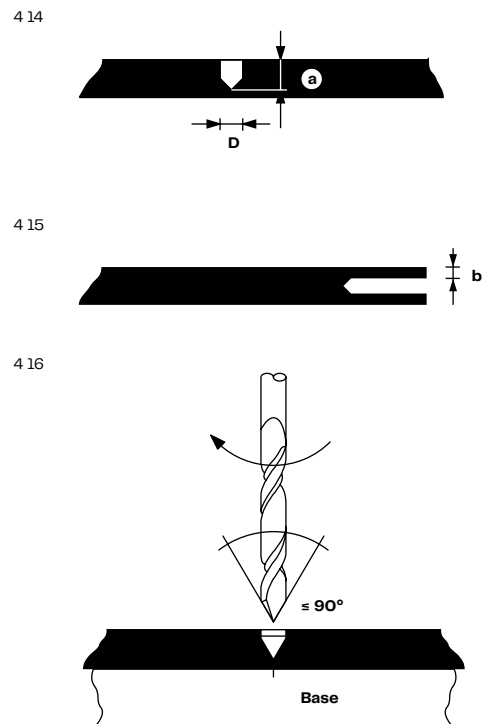

4 14 Screws perpendicular to the panel plane

4 15 Screws parallel to the panel plane

4 16 Twist drills with a point angle of $\leq 90^\circ$

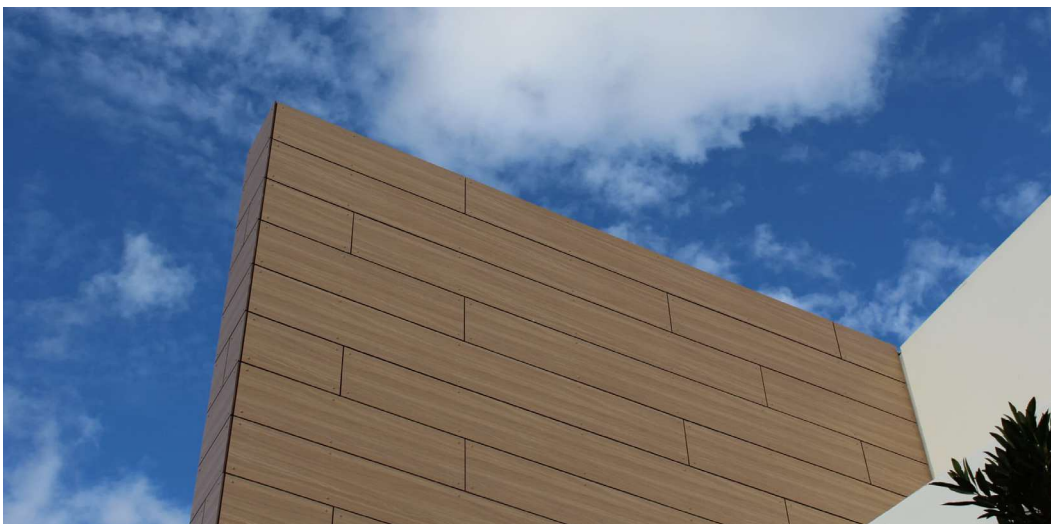

Cutting and Milling Compact Panels— Suggestions for Resolving Processing Issues

Clamping Parts onto a Machine Table

There are two options for securing or clamping Max Compact Exterior panels onto a machine table, and one of these should be chosen depending on the type of processing. For both options, it is important to ensure that the suction cups are of an adequate size. If it is not sufficient, check the seals (e.g., sealing rings of the suction cups).

Securing by means of spaced-out suction cups:

In the case of milled panel parts or those with edge processing on both sides, it is recommended that they are secured using spaced-out suction cups. Take care to ensure the rights spacing between the suction cups.

Securing by means of an MDF protective board:

In the case of milled panel parts and those with edge processing on one side, or those to be milled with holes or custom shapes, it is recommended that they are secured using an MDF protective board (can be used several times).

Spacing of the Suction Cups

To prevent the material from shaking and vibrating, the spacing of the suction cups and the edge of the panel that protrudes over the edge should be adapted to the thickness of the panel. The more suction cups and the smaller the distance from the protruding edge, the cleaner the milling pattern. As a rule of thumb, you can apply a maximum 300.0 mm grid to the area to be worked on, and the protruding edge of the panel should be no more than 30.0 mm. An MDF protective board (e.g., 19.0 mm thick) provides the best results because it ensures full-surface vacuum fixation on the Max Compact Exterior panel on the machine table.

Choice of Machining Tool

Max Compact Exterior panels can be machined with solid carbide (VHM) as well as diamond (PCD) milling tools. To ensure a clean milling pattern and a long service life, use vibration-free tool holders and spindles. You must also make sure the ball bearings are properly maintained! Diamond tools have proven particularly suitable for processing a large number of panels or a high number of running meters. Smooth-running milling cutters with a shank diameter of min. 10.0 mm in combination with straight continuous DIA cutting edges (2+1 blade) are especially suitable for format milling. Make sure that the feed rate and the cutting speed are adjusted for the specific job and cutter based on the material being processed. If necessary, raise the issue with the tool manufacturer.

Milling Tool Clamping Device

The positioning of the spindle in the chuck is crucial for ensuring the smooth running of the milling cutter. The more centered and play-free the milling cutter can be clamped in place, the better the result. Most machines are equipped with common tool holders (e.g., collets, hydro grips, or shrink chucks). For professional CNC machining for larger jobs, a hydro grip tool holder or shrink chuck is recommended (they guarantee the best tool clamping). Ensure proper maintenance of all moving parts (e.g., slide or ball bearings) to avoid vibrations in all axial directions.

Suction

The suction and suction capacity must be adjusted according to the material being processed to ensure that all the shavings are removed as effectively as possible. If the suction is not strong enough, there is a risk of heat being generated. This is due to shavings that remain between the cutter and the panel edge causing a high degree of friction, as the material cannot be ejected any further. This can potentially lead to burn marks on the edge of the panel.

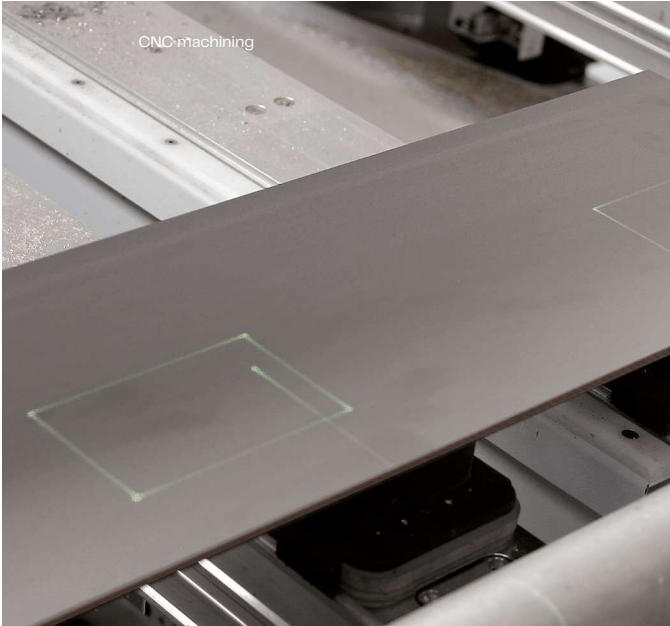

CNC Machining by Fundermax

Fundermax has its own machining center, Compact Elements, where we offer CNC machining of Max Interior, Max Compact Exterior, and Max HPL. If this is something you are interested in, please contact our customer service center.



5 Facades



“Beautiful facades are like a positive first impression.”

(Lydia H., building developer)



Function and Advantages of Rainscreen Facades	32
Material Characteristics	34
Installing Max Compact Exterior Panels Using Exposed Fasteners on an Aluminum Substructure	35
Installing Max Compact Exterior Panels Using Screws on a Timber Substructure	44
Important information about Rainscreen Facades on a Timber Substructure	48
Concealed Fastening	50
Modulo Fastening	58
Scaleo Fastening	66

Function and Advantages of Rainscreen Facades

Insulation

The rainscreen facade system can be applied for various energy requirements with individually calculated insulation (insulation thickness). This will allow you to achieve the U-values needed for a low-energy building and meet the requirements of energy-saving regulations. The insulation works by storing as much heat as possible, balances out high summer temperatures in the interior, and minimizes CO₂ emissions (reduction in heat energy).

Preventing Condensation

Rainscreen facades cause an outwardly decreasing vapor diffusion resistance: Moisture caused by the structure or usage dissipates through the rear ventilation space. This ensures the insulation is sustainable and creates a pleasant interior climate.

Rain Protection

Rainscreen facades are part of stress group III according to the DIN 4108-3 standard and are resistant to driving rain. Moisture quickly dissipates in the rear ventilation space between the insulation and the cladding (weather protection).



Notes

Up-to-date and more comprehensive documents on all standards and approvals regarding Max Compact Exterior can be found here:
<https://fundermax.us/code-compliance-and-testing/>

Ecology—Sustainability

Minimizing CO₂ emissions: Environmental targets are achieved in new builds and renovations by using rainscreen facades, as measurable reductions in heat energy minimize the emission of carbon dioxide. Government and regional funding schemes for facade renovations to reduce energy consumption are available.

Economy

Cost-effectiveness due to a long life span, long maintenance intervals, and later return of the components into the material cycle.

Cost Security

Even in renovation projects, estimating the cost of a rainscreen facade is generally a case of precise cost planning.

Advantages of a Rainscreen Facade

- Precise facade cost estimate
- Installation process not dependent on weather
- Short, cost-efficient scaffolding time
- No disposal expenses during the installation phase
- Long maintenance intervals and low subsequent costs
- Long-term value retention and appreciation of the building

Construction Basics

Do not expose the material to any standing water—panels must be able to dry out. Bonded panels should always be joined in the same running direction. Max Compact Exterior panels may display variations in flatness (see EN 438-6, 5.3). This can be offset by stable, level construction of the substructure. All joints with other building elements or the subsurface should be securely closed. Avoid any flexible intermediate layers with the substructure, and between the parts of the substructure that have a tolerance of more than ±0.5 mm.

Regional building regulations should always be observed.

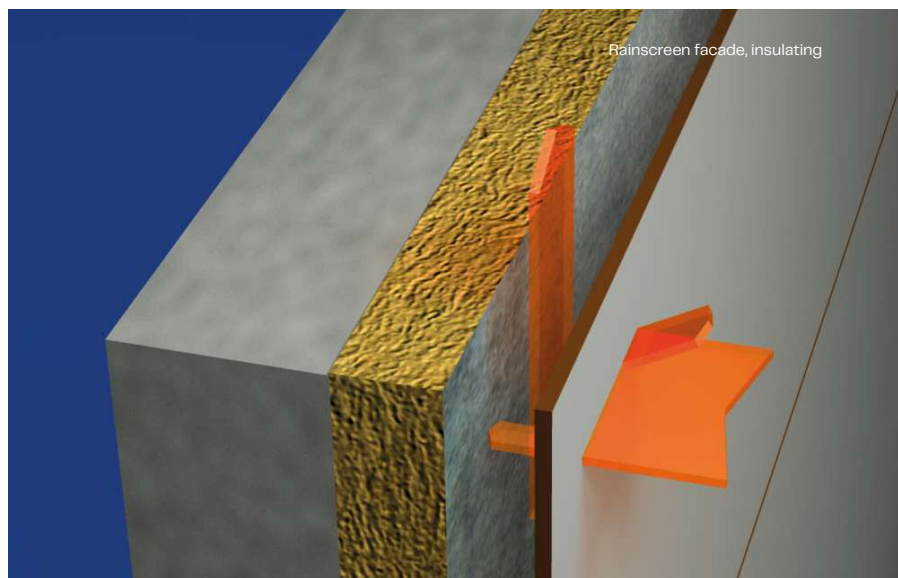
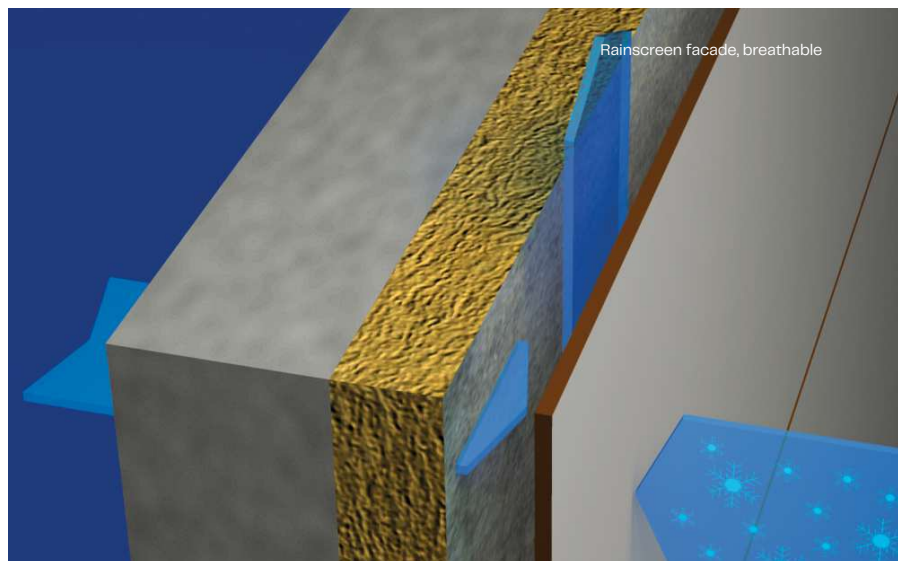

Material Characteristics

Max Compact Exterior shrinks when moisture is released and expands when moisture is absorbed. Any possible changes in size should be taken into account during machining and construction. This is basically about half as much lengthwise as crosswise.

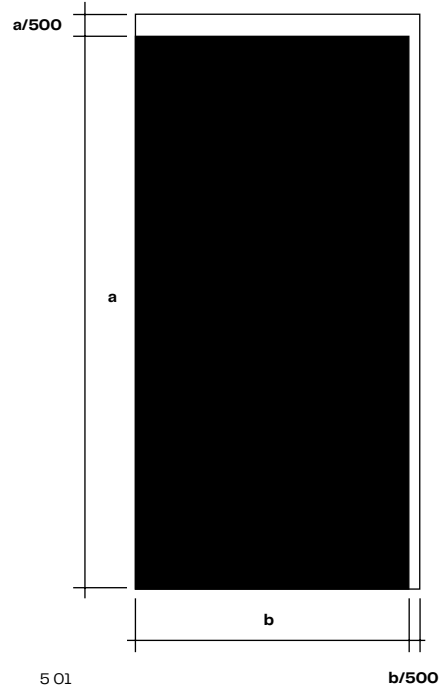

(see properties on page 10)
lengthwise related to nominal panel size.

Element length = a
Element width = b

a or b (in mm)/500 = expansion clearance

Installing Max Compact Exterior Panels Using Exposed Fasteners on an Aluminum Substructure*

Panel Thicknesses : 8mm, 10mm

Fasteners

Aluminum blind rivet with large head or SFS TWS-D13 screw, color lacquered, for metal substructures.

Substructure

Aluminum substructures must comply with national standards and be installed according to manufacturers' guidelines. Based on the material characteristics of Max Compact Exterior: Fasten using fixed (expansion) and sliding point fixings (see page 36, Fig. 5 03 and page 36, Fig. 5 04). The dimensions of metal substructures change according to changes in temperature, but the dimensions of Max Compact Exterior change under the influence of varying relative humidity. These dimensional changes of the substructure and cladding material can work in opposing directions. Therefore, it is important to ensure sufficient expansion clearance during installation.

Rear Ventilation Provisions

To avoid condensation building up in the rainscreen facade, always ensure proper ventilation. The clear vertical rear ventilation gap must be a minimum of 3/4". To allow for vertical throughflow, arrange support frames vertically.

5 02

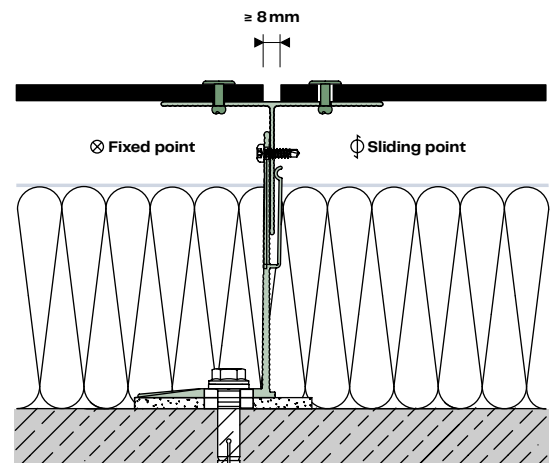
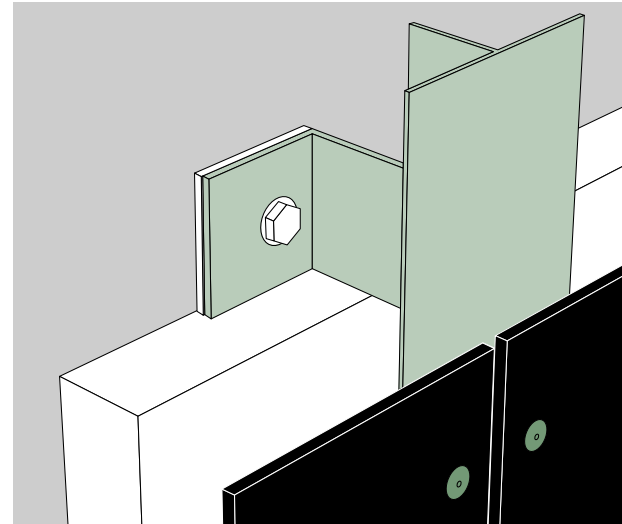

Example vertical joint

Notes

For suppliers of fasteners and substructures, see the end of the brochure or visit www.fundermax.com.

* For approved systems to mount exterior insulation behind Fundermax panels, please contact us.

- 5 01 Dimensional change with moisture release or absorption
- 5 02 Installation using rivets

Forming Joints

To ensure that Max Compact Exterior panels can move without restriction, joints should be at least 8.0 mm.

Fixed Point

Fixed points serve to evenly distribute (halve) changes in size. The drilling diameter for Max Compact Exterior panels is 5.1 mm for rivets, 6mm for screws. Fundermax panels use (1) one fixed point per panel.

One fixed point is required per panel. For panels arranged in groups, the fixed point should be positioned in the same place on all panels.

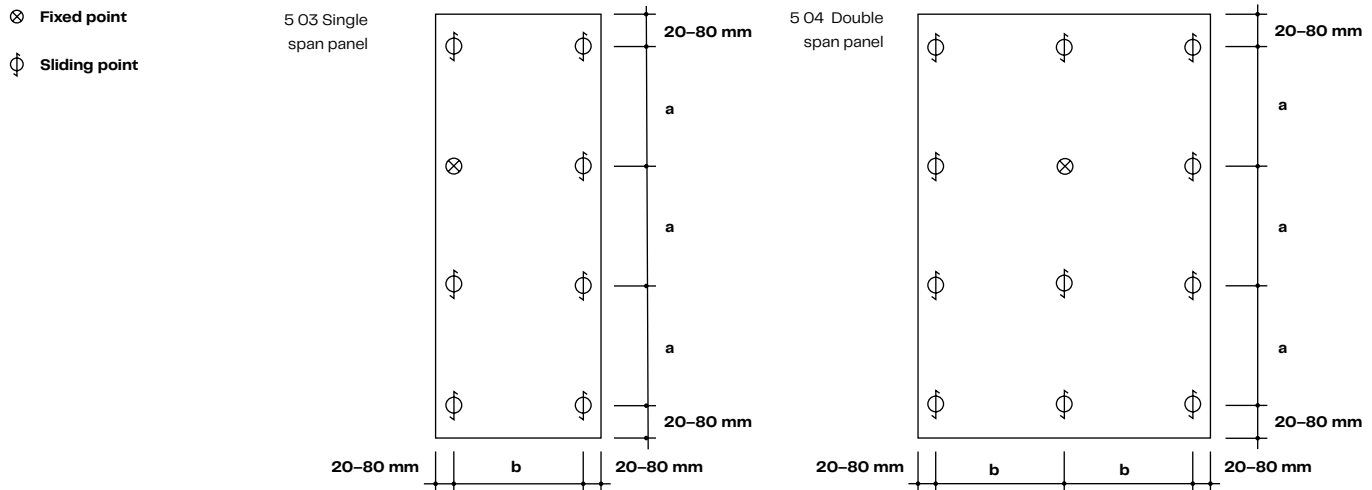

Distance from Edge

Maintain a distance from the edge of 20.0–80.0 mm to ensure stability and flatness. For dimensional changes, ensure joints between panels are at least 8.0 mm. Minimum edge distance $3/4"$, maximum edge distance $3 1/4"$ (see Fig. 5 03, page 36).

Fastener Spacing

Observe relevant structural requirements. If this is not necessary due to local building regulations, consult the values in the tables on each individual fastening system. Choose smaller fastener spacings on the edge of a structure than in the center (pressure, suction).

Single Fastener Panels

Panels 4" or less wide may use one fastener across, panels larger than 4" wide must use two (2) fasteners.

Sliding Points

The diameter of the drill hole in the Max Compact Exterior panel must be larger than the diameter of the fastener, depending on the required expansion clearance. The diameter of the drill hole is the shaft diameter of the fastener plus 2.0 mm per meter of cladding material starting from the fixed point. All fastener holes other than the (1) Fixed point must be sliding points. For panels up to 9', 8mm sliding points. For panels larger than 9', 9.5mm sliding points.

The fastener head must cover the drill hole. Set fasteners so that the panel can move.

The center of the drill hole in the substructure should match the one on the Max Compact Exterior panel—use a drilling jig! Start fastening the panels at the center of the panel and work outward.

Rivets should be applied using a suitable special gauge attachment (allowance: 0.3 mm).

- Fasteners: SFS TW S D13 (metal substructure)
- SFS TWS D12 (wood substructure)
- SFS AP16 Rivet (metal substructure)

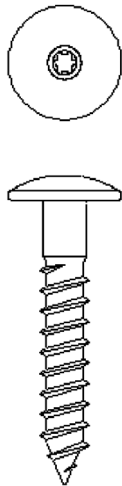

SFS TW-S-D13
Screw for metal
substructure

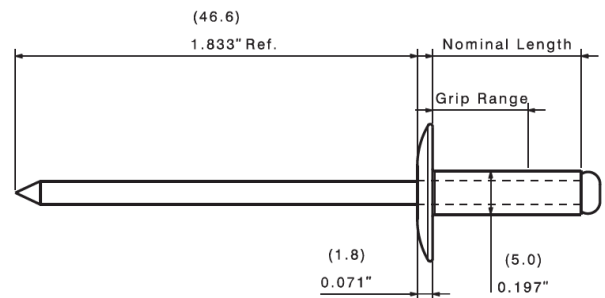
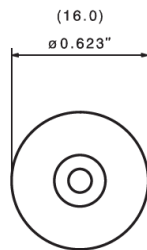

SFS AP16-5 Rivet for metal substructure



SFS Centering Tool, Item Number 700745

Note

Centering Tool must be used on all exposed fastener applications. If self-drilling fasteners are used, the appropriate slotted centering tool must be used. Rivets must be installed with the manufacturer's recommended centering nose piece and rivet gun. Failure to use these tools will likely result in flatness issues on the panels.

Curved shapes

Under force, Max Compact Exterior panels can be formed cold. The bend radii possible are associated with the thickness of the panel: the thinner the panel, the smaller the possible radius.

Fastening:

Fastening should be carried out mechanically. Choose spacing according to structural requirements. Panels must be supported by the pre-curved substructure. Careful workmanship is critical. Take note of the building regulations, recommendations, and notes in this brochure, and the appropriate number of fasteners.

Curved panels may only be done with exposed fasteners!

Smallest possible bend radii without wind load:

- Panel thickness 6.0 mm: Radius 2,500 mm (approx. 98")
- Panel thickness 8.0 mm: Radius 3,500 mm (approx. 137")
- Panel thickness 10.0 mm: Radius 4,500 mm (approx. 177")

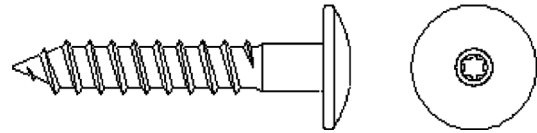

Pathways Academy of Technology & Design at Goodwin College | Photo Credit Roof Tech Sales

Windload Tables for 8 and 10 mm Exposed Fastener Walls

Exposed Fastener Fundermax Wall Panel System Load Charts

Panel Thickness: 8 mm

No. of Fasteners		Wind Pressure (psf)								
		15	20	25	30	35	40	45	50	55
1 Fastener into Aluminum Extrusion	Fastener x-spacing (in)	32	32	32	32	32	32	32	32	32
	Fastener y-spacing (in)	30	30	X	X	X	X	X	X	X
	Fastener x-spacing (in)	24	24	24	24	24	24	24	24	24
	Fastener y-spacing (in)	30	30	30	29	26	23	20	18	X
	Fastener x-spacing (in)	16	16	16	16	16	16	16	16	16
	Fastener y-spacing (in)	30	30	30	29	28	27	26	25	24
		60	65	70	75	80	85	90	95	100
	Fastener x-spacing (in)	32	32	32	32	32	32	32	32	32
	Fastener y-spacing (in)	X	X	X	X	X	-	-	-	-
	Fastener x-spacing (in)	24	24	24	24	24	24	24	24	24
	Fastener y-spacing (in)	X	X	X	X	X	X	X	X	X
	Fastener x-spacing (in)	16	16	16	16	16	16	16	16	16
	Fastener y-spacing (in)	23	21	20	18	17	16	15	14	14

Exposed Fastener Fundermax Wall Panel System Load Charts

Panel Thickness: 10 mm

No. of Fasteners		Wind Pressure (psf)								
		15	20	25	30	35	40	45	50	55
1 Fastener into Aluminum Extrusion	Fastener x-spacing (in)	32	32	32	32	32	32	32	32	32
	Fastener y-spacing (in)	30	30	27	23	20	17	X	X	X
	Fastener x-spacing (in)	24	24	24	24	24	24	24	24	24
	Fastener y-spacing (in)	30	30	30	30	26	23	20	18	17
	Fastener x-spacing (in)	16	16	16	16	16	16	16	16	16
	Fastener y-spacing (in)	30	30	30	30	30	30	30	27	25
		60	65	70	75	80	85	90	95	100
	Fastener x-spacing (in)	32	32	32	32	32	32	32	32	32
	Fastener y-spacing (in)	X	X	X	X	X	X	X	X	X
	Fastener x-spacing (in)	24	24	24	24	24	24	24	24	24
	Fastener y-spacing (in)	15	14	13	12	11	11	10	10	9
	Fastener x-spacing (in)	16	16	16	16	16	16	16	16	16
	Fastener y-spacing (in)	23	21	20	18	17	16	15	14	14

Notes:

1. Fastener x-spacing denotes the design horizontal spacing of the fastener at which the maximum vertical y-spacing was calculated.
2. Fastener y-spacing denotes the calculated maximum vertical spacing of the fastener based on design wind speed, # of fasteners, and x-spacing.
3. Chart Utilizes AAMA TIR-A9-14 Table 22.4 for the allowable pullout of #12 fasteners into 6063-T5 1/8" thick aluminum.
3. Chart Utilizes TW-S-D13 Pan Head 304 Austenic Stainless Steel self-tapping fasteners.
4. Aluminum panel extrusions are not included in this calculation package and must be independently verified by a licensed professional engineer.
5. "-" Indicates that denoted x-spacing cannot be achieved before panel bending stress failure occurs.
6. "X" Indicates that denoted x-spacing cannot be achieved before panel exceeds L/120 deflection criteria.
7. Panel and panel fasteners are not designed for seismic, live loads, wind borne debris, impact, blast loads, handrail/fall protection loads, or buiding movement.
8. Load Span Table is based on Allowable Stress Design (ASD).

NOTE: These values are design guidelines only and not a substitute for project specific calculations.

Construction Details - Exposed Fastening

COLOR MATCHED SCREWS

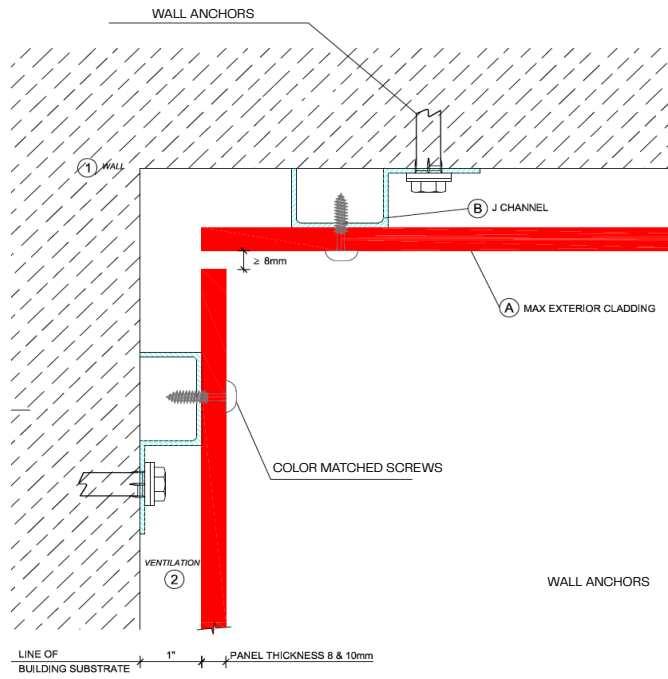

A105

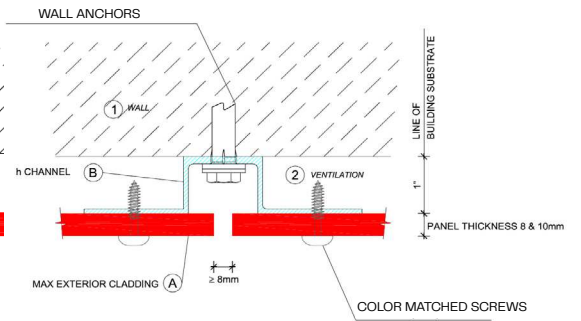

A107

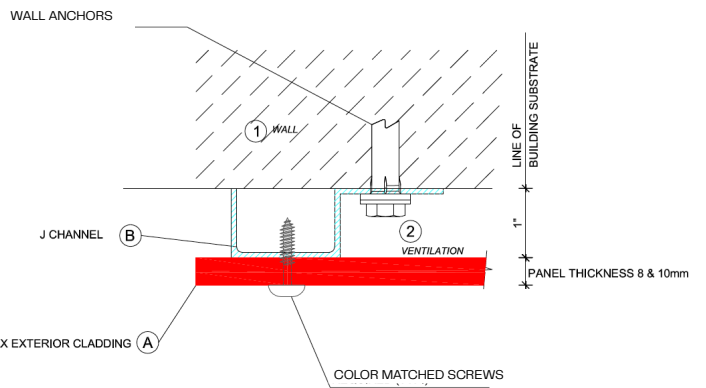

A104

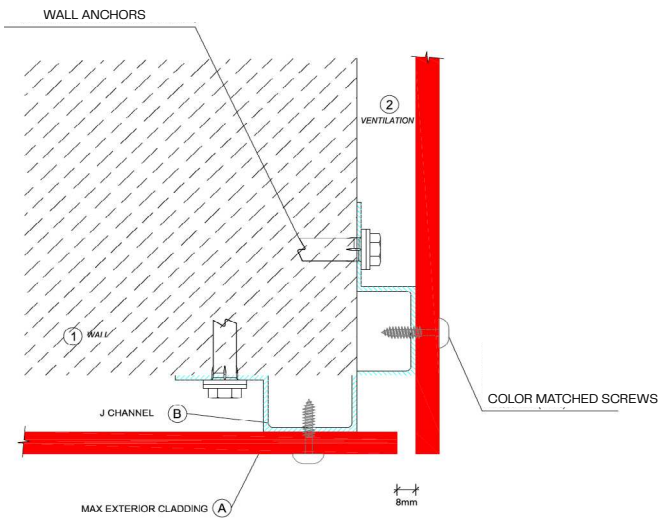

A106

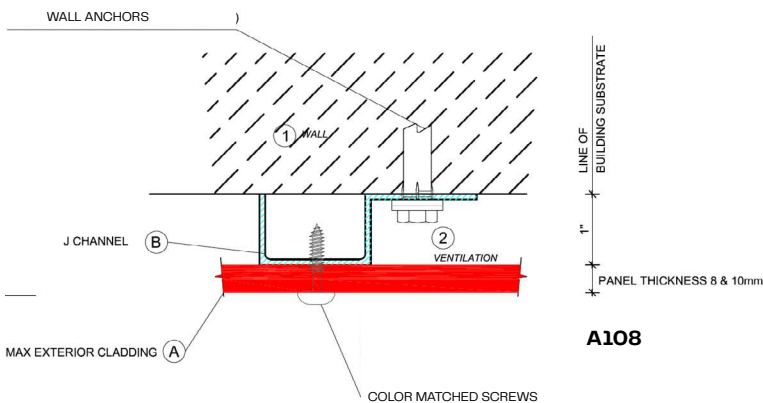

A108

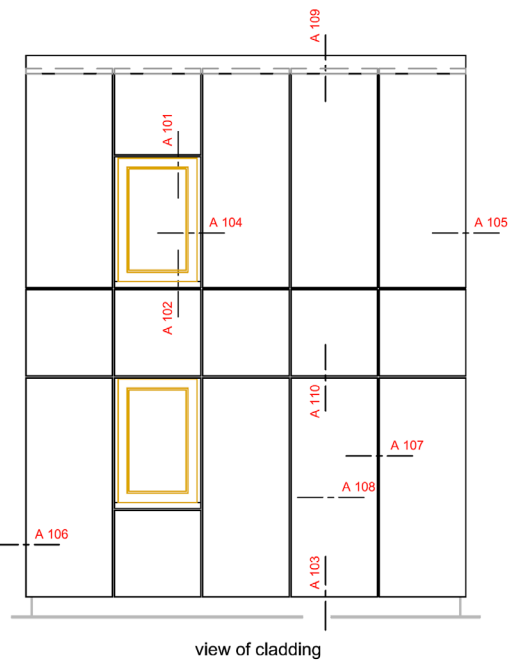

view of cladding

For full system details, please visit fundermax.us/system-details
 Fundermax 8 and 10mm Exposed Fastener Installations are NFPA285 compliant when installed per our Intertek CCRR Report, details at <https://specdirect.intertek.com/controls/SDDocumentViewer.aspx?ccrr=CCRR-0527>

Construction Details – Exposed Fastening

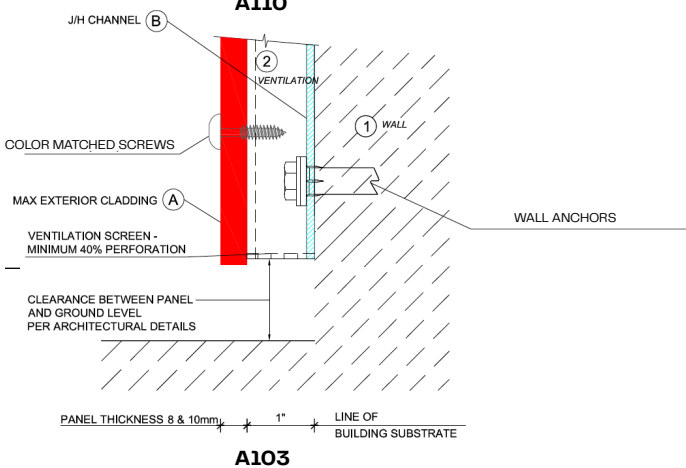
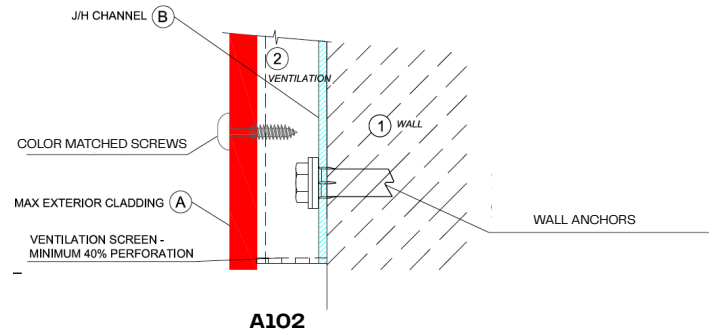
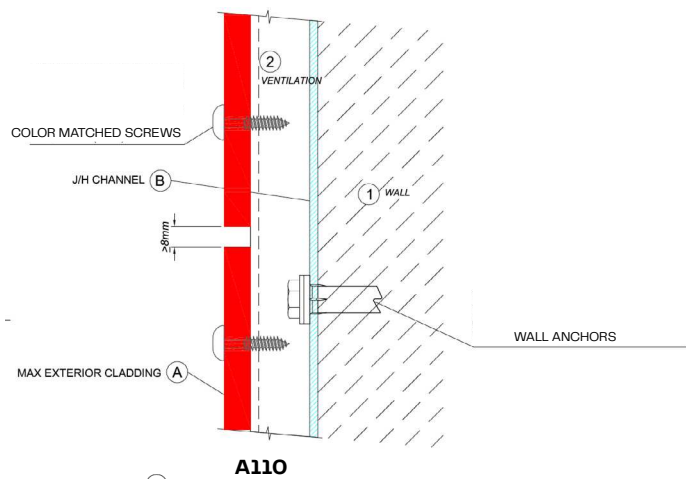
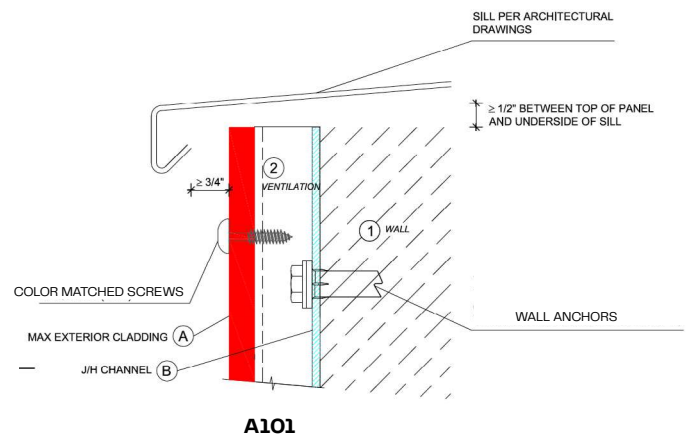
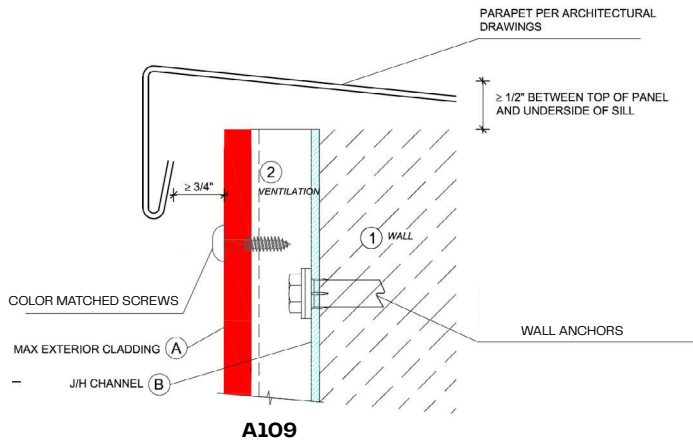

Construction Details - Aluminum Substructure with Z/Omega Profiles and Exposed Fasteners

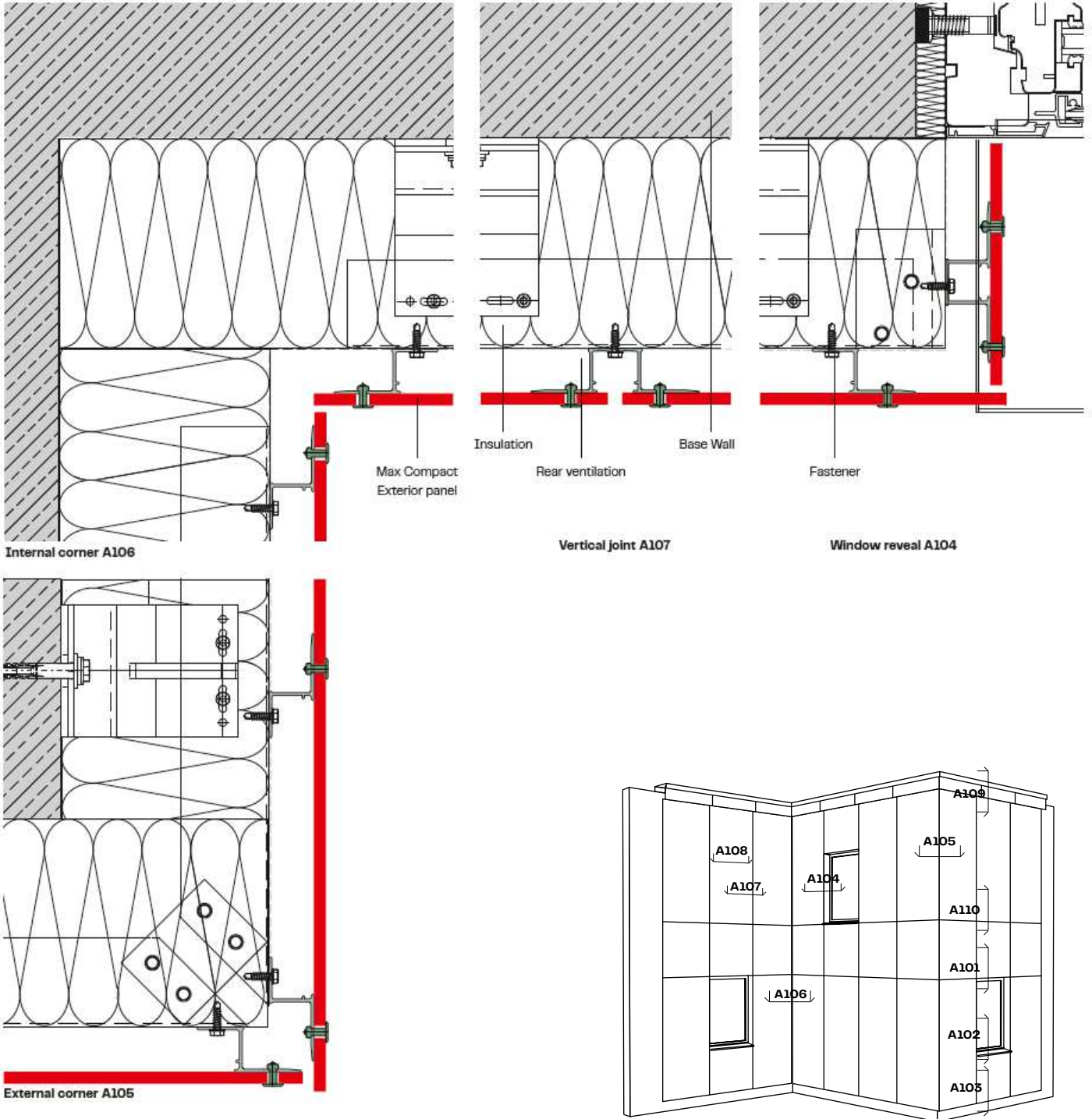

Note:
All of the profiles and fasteners shown in this brochure are suggestions for planning purposes and not part of Fundermax's scope of delivery. Drawings are NOT to scale.

Suppliers:
See end of the brochure.

Construction Details - Aluminum Substructure with Z/Omega Profiles and Exposed Fasteners

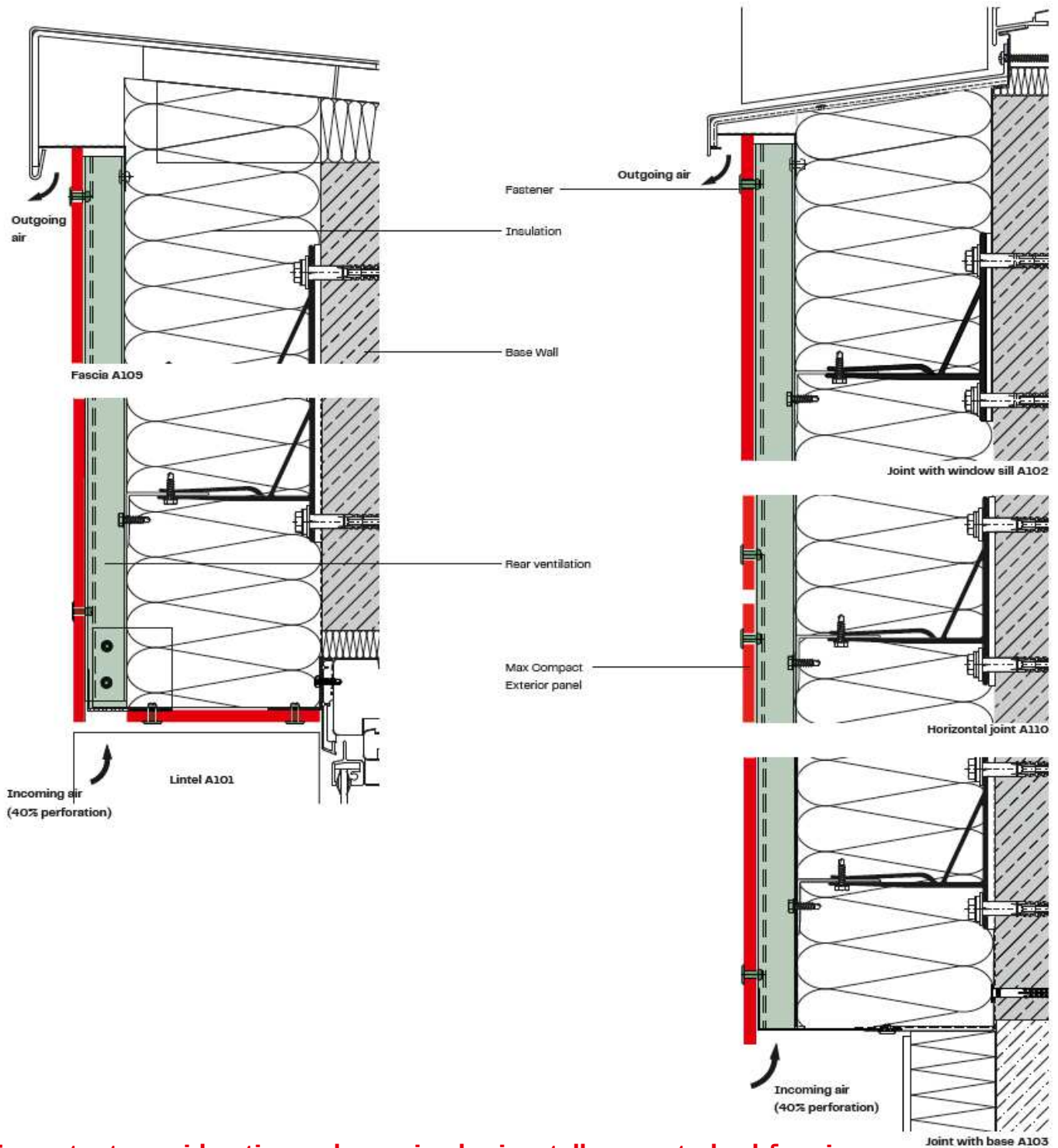

Important considerations when using horizontally mounted subframing

Running your sub-framing vertically behind Fundermax panels should always be the first choice, however certain panel layouts will lend themselves to be more easily installed with a horizontal system behind. For example, all narrow vertical plank layouts would also then have a lot of sub-framing behind when an all vertical system is used. In some scenarios, a horizontal system can save material and labor for installation, which can add up significantly on your project.

HPL's are wood based (up to 65%), so having the proper amount of airflow and drainage is critical to material performance. Incorrect sub-framing can have a major impact on this and void product warranties. Not all horizontally vented systems work for HPL's and should always be checked for adequate ventilation. Depending on installed height (NFPA285 over 40' installed height), this can sometimes be achieved by using a 1/4" shim behind a horizontal 3/4" or 1" deep extrusion. Fundermax panels require 2.36 Square inches per lineal foot (or running foot) of vertical airflow (open space) with 1" sub-framing running horizontally.

Installing Max Compact Exterior Panels Using Screws on a Timber Substructure

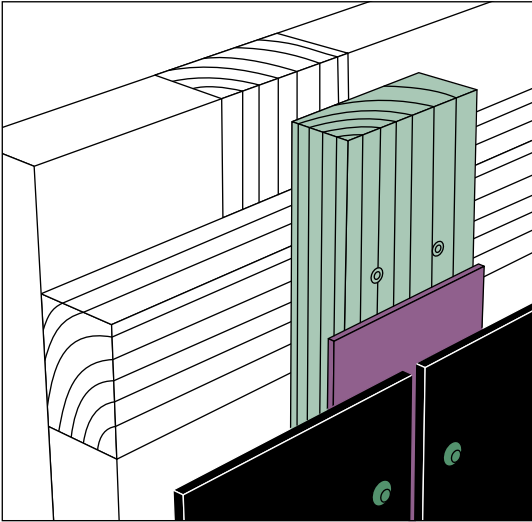

5 05

Substructure

Set the dimensions of horizontal battens and counterbattens at a minimum of 60.0 x 40.0 mm (2 3/8" x 1 5/8"), vertical battens at a minimum of 50.0 x 30.0 mm (2" x 1 1/8"). Joints: 100.0 x 30.0 mm (4" x 1 1/8"). Due to the characteristics of the Max Compact Exterior material, it is necessary to drill fixed and sliding points at the time of installation (see Fig. 5 03 and Fig. 5 04 on page 36). In the case of thicker insulation, counterbattens should be made (Fig. 5 05).

Note:

To achieve the best possible facade cladding look with the NG surface, installation on an aluminum substructure is recommended. Subframe types such as timber are not suitable because of their material-related properties, as any unevenness in the substructure will cause a wavy overall appearance.

Fixed Point

Fixed points serve to evenly distribute (halve) changes in size. Drill hole diameter in Max Compact Exterior panels: 6.0 mm.

Sliding Point

The diameter of the drill hole in the Max Compact Exterior panel must be larger than the diameter of the fastener, depending on the required expansion clearance. The diameter of the drill hole is the shaft diameter of the fastener plus 2.0 mm per meter of cladding material starting from the fixed point. The fastener head must cover the drill hole. Apply fasteners starting from the fixed point and working outward. Position screws centrally in the panel holes and do not screw in too tight (the panel should still be able to move). The spacing of screw heads on the surface of the panel should be 0.3 mm to allow for movement of the parts in the drill hole. Do not use countersunk screws. Use a centering aid.

Forming Joints

To ensure that Max Compact Exterior panels can move without restriction, opt for joints of at least 8.0 mm (5/16").

Fasteners

Only use fasteners made out of non-corrosive materials—Max Compact Exterior installation screw (see Fig. 5 06) with Torx 20 made out of stainless steel. Lacquered head available on request.

Drill hole diameter in

Max Compact Exterior panels:

Sliding points: 8.0 mm/as required, fixed points: 6.0 mm

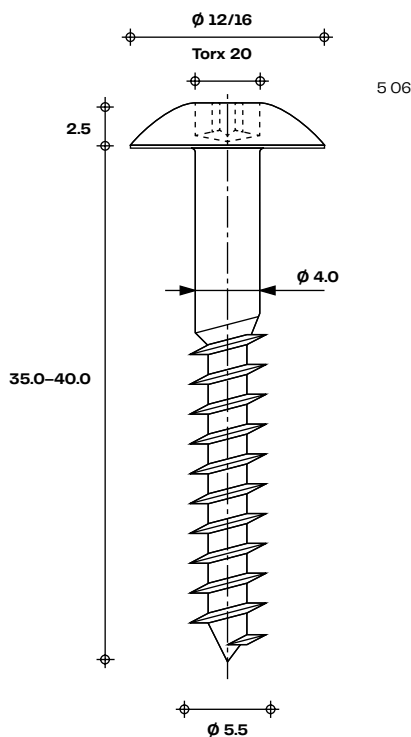

Distance from Edge

Maintain a distance from the edge of 20.0–80.0 mm (3/4" - 3 1/4") to ensure stability and flatness. Ensure joints between panels are at least 8.0 mm (5/16") to accommodate dimensional changes (see Fig. 5 07).

Fastener Spacing

Observe relevant structural requirements.

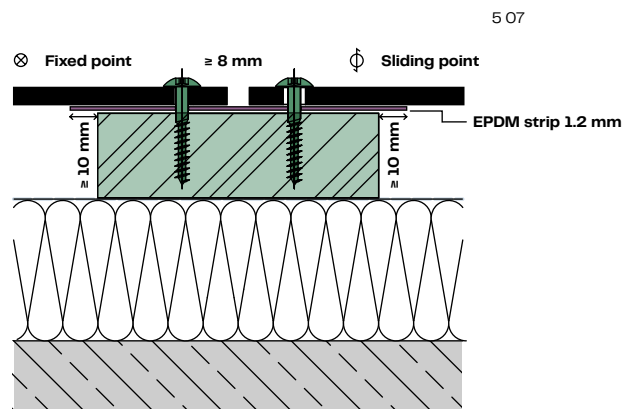

Construction Details—Timber Substructure

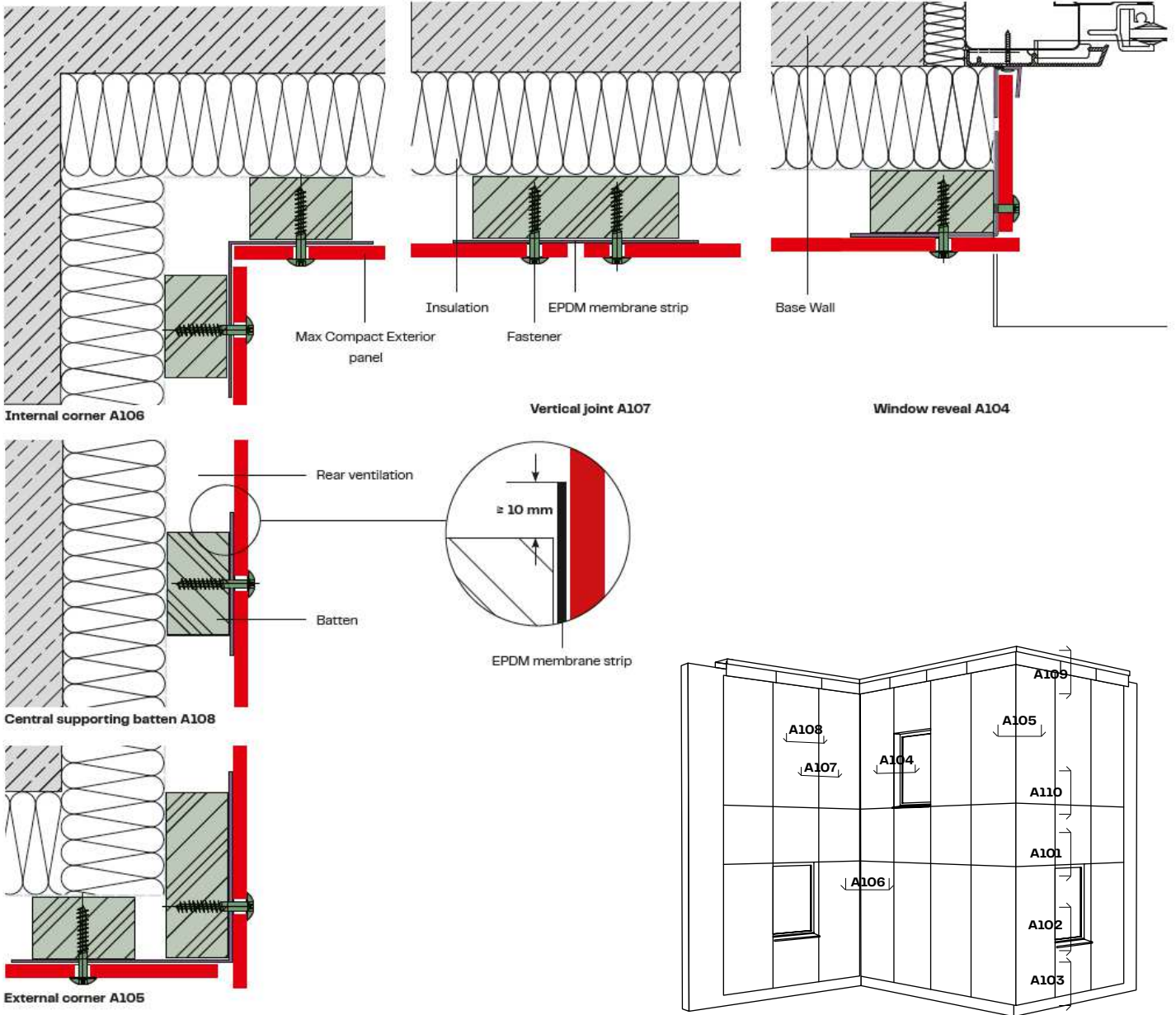

Note:
 All of the profiles and fasteners shown in this brochure are suggestions for planning purposes and not part of Fundermax's scope of delivery. Drawings are NOT to scale.

Suppliers:
 See end of the brochure.

Construction Details—Timber Substructure

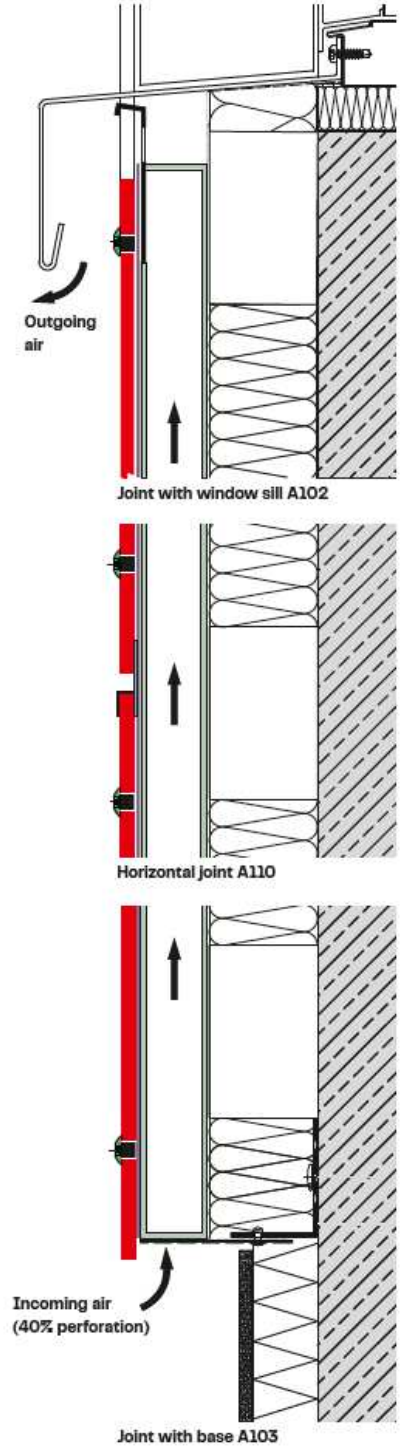
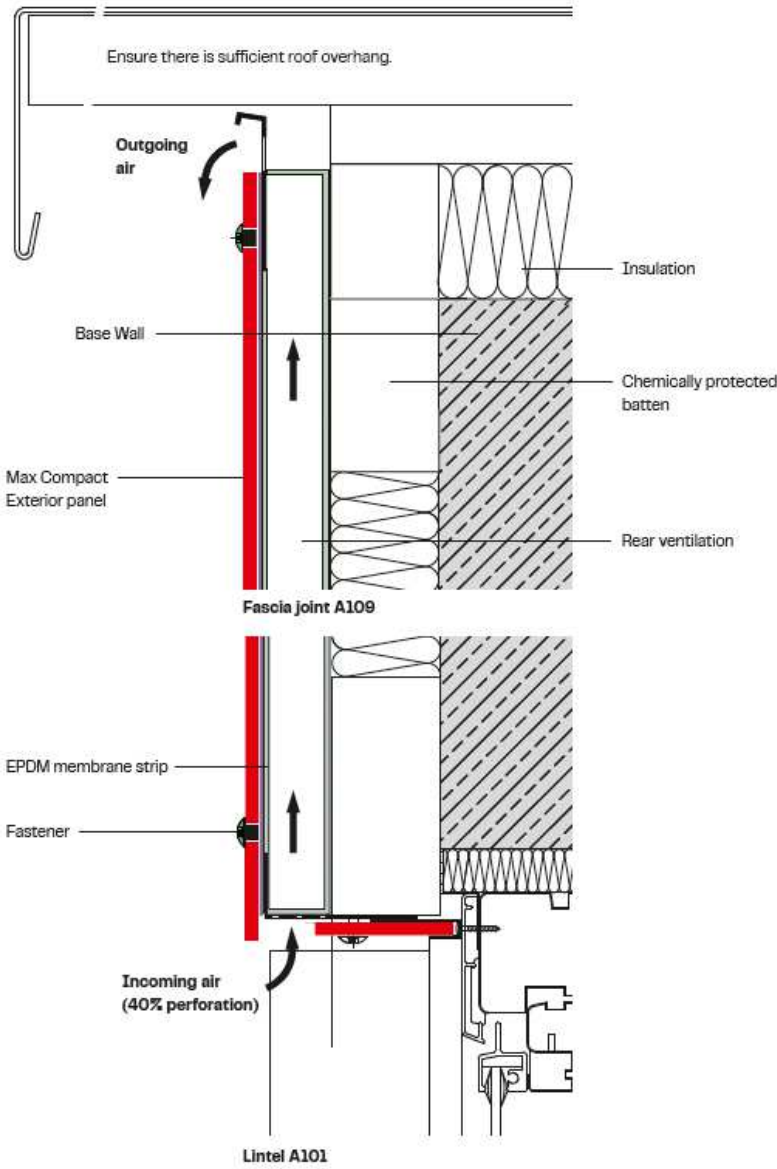

Important information about rainscreen facades on a timber substructure

The advantages of timber substructures are minimal thermal conductivity and longitudinal expansion, as well as the fact that wood is a renewable resource. To ensure durability, protection against moisture by means of construction design or chemical protection is essential.

To prevent moisture ingress via the screws, use pre-dried, planed battens (timber moisture content $15\% \pm 3$), e.g., spruce, fir, pine, or larch, as well as an EPDM membrane strip with a minimum thickness of 1.2 mm. Avoid moisture under the EPDM membrane strip in joints with fascias and windows!

Since wood behaves like a natural material, it is necessary to carry out regular visual checks of the facade. Tighten screws as required. Installation on a timber substructure must be carried out with prefabricated panels (cut, drilled, and beveled, if applicable).

Timber Protection by Means of Construction Design

According to standards, structural protective measures for timber include design- and construction-related processing and machining provisions that serve to preserve the usability of wood and wood-based materials. These measures prevent fungal infestations and excessive shrinkage and swelling. These measures will not prevent insect infestations.

Taking the measures below into account will have an impact on the functionality and life span of the substructure. When building timber substructures for facades, up-to-date processing guidelines for timber structural engineering apply, subject to the installation location or other guidelines. The contractor is responsible for ensuring compliance. For that reason, construction-related and chemical timber protection should be specified during the planning phase for the substructure.

**Fixed point hole D = 6.0 mm /
do not use countersink**

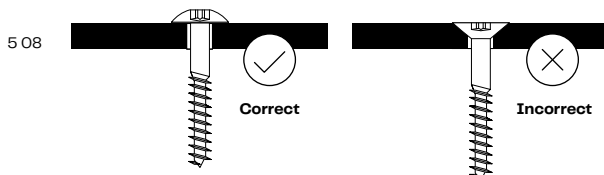

**Sliding point hole D = 8.0 mm /
do not use countersink /
for hole diameter, see page 62**

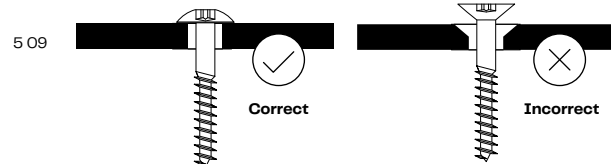

Effective Protective Measures

Protection against moisture penetration in battens:

Using an EPDM membrane strip at least 1.2 mm thick. Only this minimum thickness will seal the drill hole completely and prevent moisture ingress via the fastening screws. The strip should be used on all battens and be at least 20.0 mm (3/4") wider than the batten (see fig. 5 05 on page 46). This prevents wood-decay fungi, which grow when the moisture content is greater than 20% (DIN EN 335-1, annex A, 2.19).

Protection against precipitation:

(E.g., via a canopy, a weather cover on the fascias, window sill closures, etc.): A roof overhang will permanently prevent moisture from penetrating the facade when it rains. The size of this overhang will depend on the height of the facade and the position of the building.

Protection against spray:

Timber substructures are very sensitive to permanent moisture penetration. For this reason, they should be at least 300.0 mm (12") above the water-bearing level. In the case of smooth flooring and harsh weather conditions, the area exposed to spray increases accordingly.

Protection against rising damp:

In buildings that suffer from rising moisture, moisture-proof layers should be installed between the brickwork/concrete and the timber substructure. This will prevent persistent moisture penetration in the timber.

Protection against condensation:

(E.g., by using a vapor barrier, rear ventilation of shuttering, insulating cold water pipes): To avoid condensation constantly building up in the rainscreen facade, always ensure proper air flow.

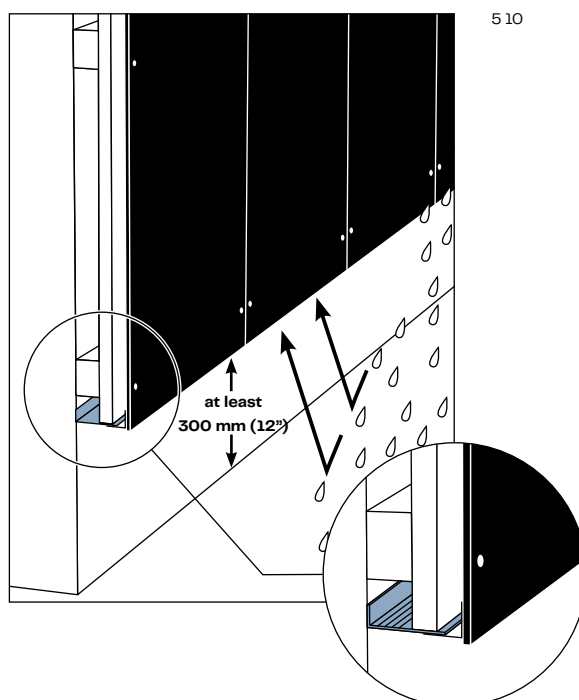

5 10

Concealed Fastening Guidelines North America

Max Exterior 10mm, 12mm (NFPA285 systems, 10mm only)

- Fasteners :2 SFS TU-F anchors per clip
- Min. residual panel material for rear anchors , 3mm. (7mm embedment in 10mm panel)
- Fastener length = clip thickness + panel embedment
- Systems can be done with or without exterior mineral wool insulation
- NFPA285 compliant systems, please see <https://specdirect.intertek.com/controls/SDDocumentViewer.aspx?ccrr-CCRR-0527>

Systems will require 1.5" airspace max, back of panel to face of wall or face of mineral wool for NFPA285 compliance . This 1.5" includes all components behind the panel (rail, clip, vertical profile, etc.).

Clip and Rail depths vary by supplier, be sure to verify actual dimensions to determine space behind needed to make the 1.5" total

For systems not requiring NFPA285, more than 1.5" is acceptable.

Any system will require an allowance for vertical airflow behind the horizontal rail/clip.

Minimum Edge Distance to 1st clip = 3/4"

Maximum Edge Distance to 1st clip = 3 1/4"



Tools Needed:

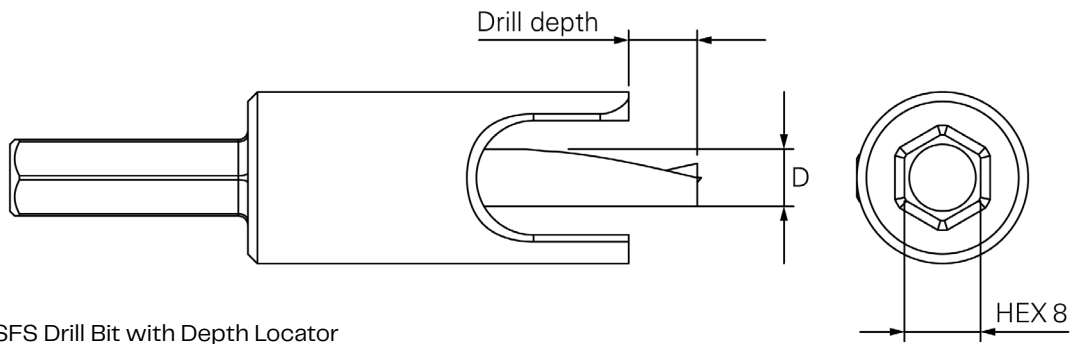

SFS Drill Bit with Depth Locator



Gesipa Powerbird Rivet Installation Tool

Approved Fastener:

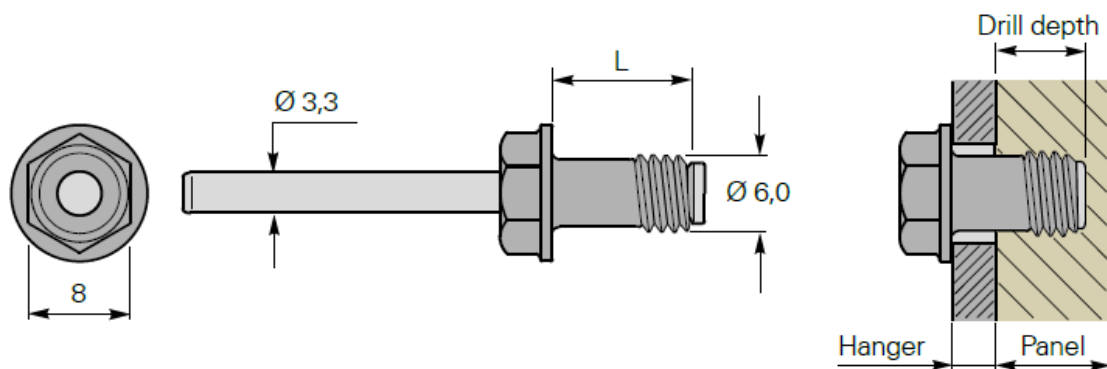

SFS TUF-S

Concealed Fastener Wall Panel System Wind Load Charts

Horizontal Rail Attachment To Substrate Spacing:		16 in									
System Summary	Clip Spacings	Wind Pressure (psf)									
		15	20	25	30	35	40	45	50	55	
10mm Panel, (2) SFS TUF-s-6xL Fasteners per Clip into Panel, 6063- T6 Aluminum Hanger Clip, 6063- T6 Aluminum Horizontal Rail, (1) 1/4"-14 Fastener into 3mm 6061-T6 Aluminum L- Profile	Clip y-spacing (in)	30	30	30	30	30	30	30	30	30	
	Clip x-spacing (in)	30	24	19	16	14	12	X	X	X	
	Clip y-spacing (in)	24	24	24	24	24	24	24	24	24	
	Clip x-spacing (in)	30	30	24	20	17	15	13	12	11	
	Clip y-spacing (in)	18	18	18	18	18	18	18	18	18	
	Clip x-spacing (in)	30	30	30	27	23	20	18	16	15	
	Clip y-spacing (in)	12	12	12	12	12	12	12	12	12	
	Clip x-spacing (in)	30	30	30	30	30	30	27	24	22	
			60	65	70	75	80	85	90	95	100
	Clip y-spacing (in)	30	30	30	30	30	30	30	30	30	30
	Clip x-spacing (in)	X	X	X	X	X	X	X	X	X	X
	Clip y-spacing (in)	24	24	24	24	24	24	24	24	24	24
	Clip x-spacing (in)	10	9	9	8	7	X	X	X	X	
	Clip y-spacing (in)	18	18	18	18	18	18	18	18	18	
Clip x-spacing (in)	13	12	11	11	10	9	9	8	8		
Clip y-spacing (in)	12	12	12	12	12	12	12	12	12		
Clip x-spacing (in)	20	18	17	16	15	14	13	13	12		

Horizontal Rail Attachment To Substrate Spacing:		32 in									
System Summary	Clips Spacings	Wind Pressure (psf)									
		15	20	25	30	35	40	45	50	55	
10mm Panel, (2) SFS TUF-s-6xL Fasteners per Clip into Panel, 6063- T6 Aluminum Hanger Clip, 6063- T6 Aluminum Horizontal Rail, (1) 1/4"-14 Fastener into 3mm 6061-T6 Aluminum L- Profile	Clip y-spacing (in)	30	30	30	30	30	30	30	30	30	
	Clip x-spacing (in)	30	22	18	-	-	-	X	X	X	
	Clip y-spacing (in)	24	24	24	24	24	24	24	24	24	
	Clip x-spacing (in)	30	28	22	19	-	-	-	-	-	
	Clip y-spacing (in)	18	18	18	18	18	18	18	18	18	
	Clip x-spacing (in)	30	30	30	25	21	19	17	-	-	
	Clip y-spacing (in)	12	12	12	12	12	12	12	12	12	
	Clip x-spacing (in)	30	30	30	30	30	28	25	22	20	
			60	65	70	75	80	85	90	95	100
	Clip y-spacing (in)	30	30	30	30	30	30	30	30	30	
	Clip x-spacing (in)	X	X	X	X	X	X	X	X	X	
	Clip y-spacing (in)	24	24	24	24	24	24	24	24	24	
	Clip x-spacing (in)	-	-	-	-	-	X	X	X	X	
	Clip y-spacing (in)	18	18	18	18	18	18	18	18	18	
Clip x-spacing (in)	-	-	-	-	-	-	-	-	-		
Clip y-spacing (in)	12	12	12	12	12	12	12	12	12		
Clip x-spacing (in)	19	17	-	-	-	-	-	-	-		

Notes:

1. Clip y-spacing denotes the design vertical spacing of the clips at which the maximum horizontal x-spacing was calculated.
2. Clip x-spacing denotes the calculated maximum horizontal clip spacing based on design wind speed, panel conditions and y-spacing.
3. Chart Utilizes SFS TUF-x-6xL concealed panel fasteners.
4. Chart Utilizes AAMA TIR-A9-14 Table 20.9 for tensile and shear capacities of 1/4"-14 stainless steel fasteners.
5. Chart Utilizes ADM 2015 J.5.4.1.1 and J.5.4.2 for determination of pullout and pullover capacities of 1/4"-14 stainless steel fasteners.
6. X Indicates that denoted clip y-spacing cannot be achieved before panel bending stress or deflection limits are exceeded.
7. "-" Indicates that carrier rail bending stress or deflection limits are exceeded at design spacings and wind pressures.
8. Panel and subframing deflection limited to L/120.
9. Panel and panel fasteners are not designed for seismic, live loads, wind borne debris, impact, blast loads, handrail/fall protection loads, or building movement.
10. Load Span Table is based on Allowable Stress Design (ASD).



Construction Details – Concealed Fastening

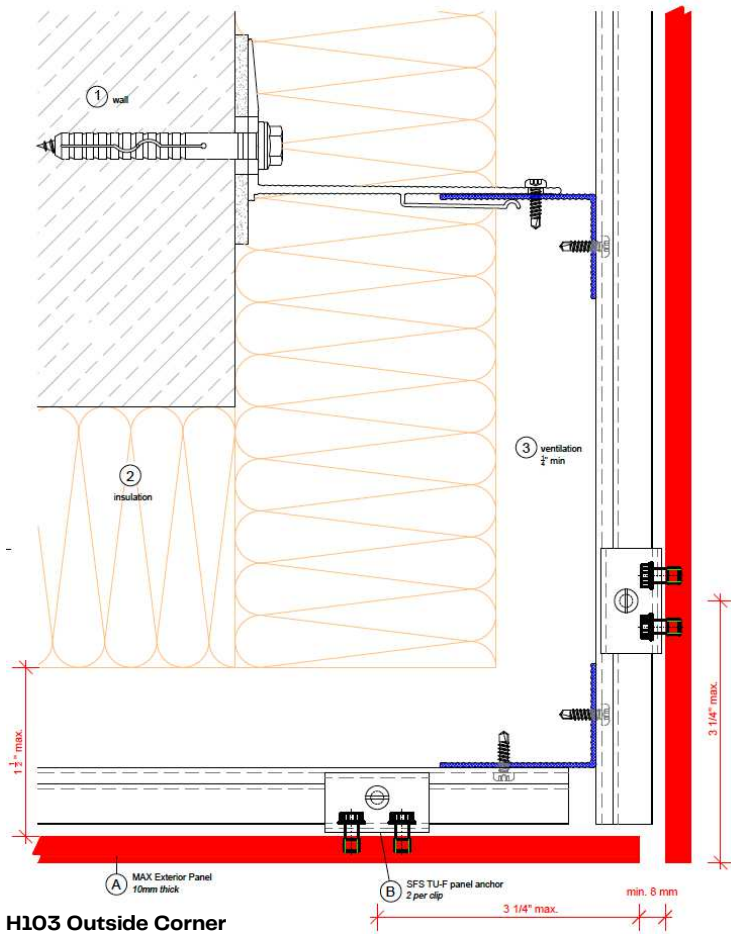

H103 Outside Corner

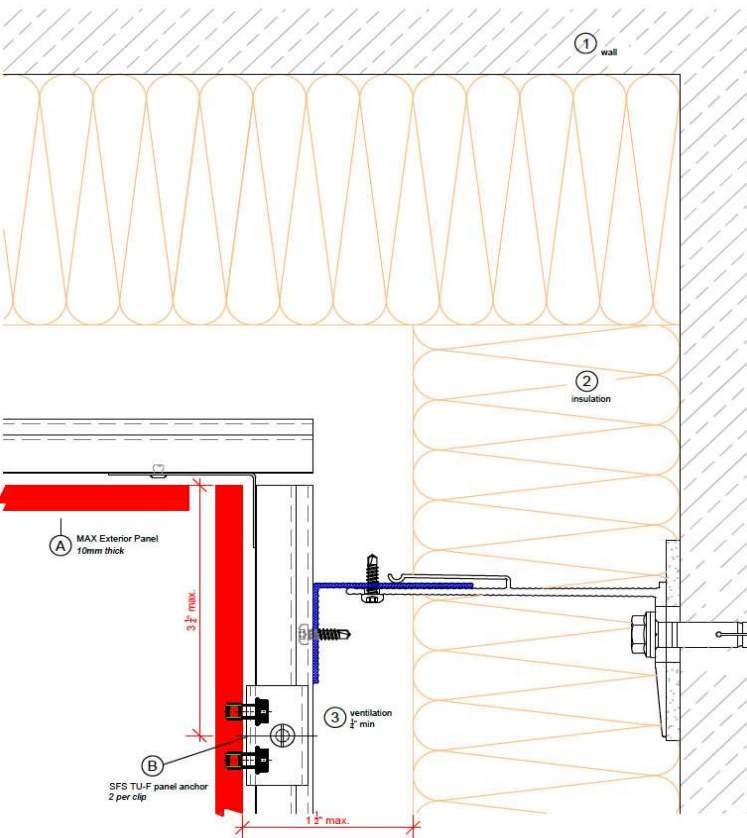

H103 Inside Corner



view of cladding

For full system details, please visit fundermax.us/system-details
 Fundermax 10mm Concealed Fastener Installations are NFPA285 compliant when installed per our Intertek OCRR Report, details at <https://spec-direct.intertek.com/controls/SDDocumentViewer.aspx?ccr=CRR-0527>

Construction Details – Concealed Fastening

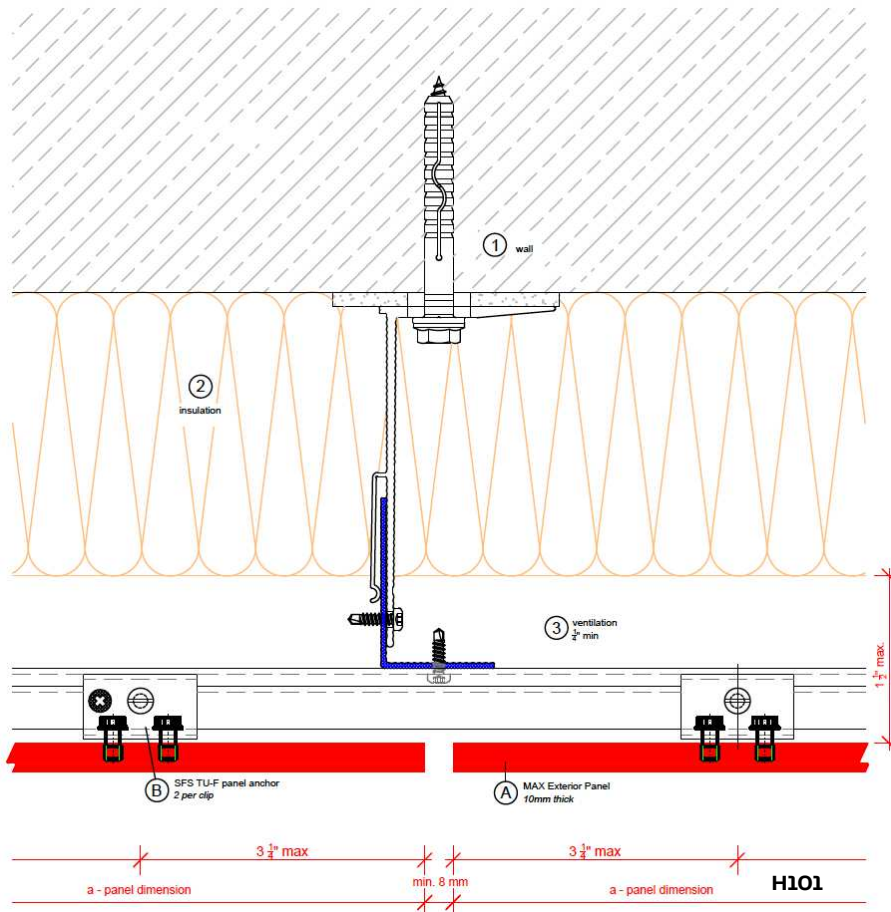
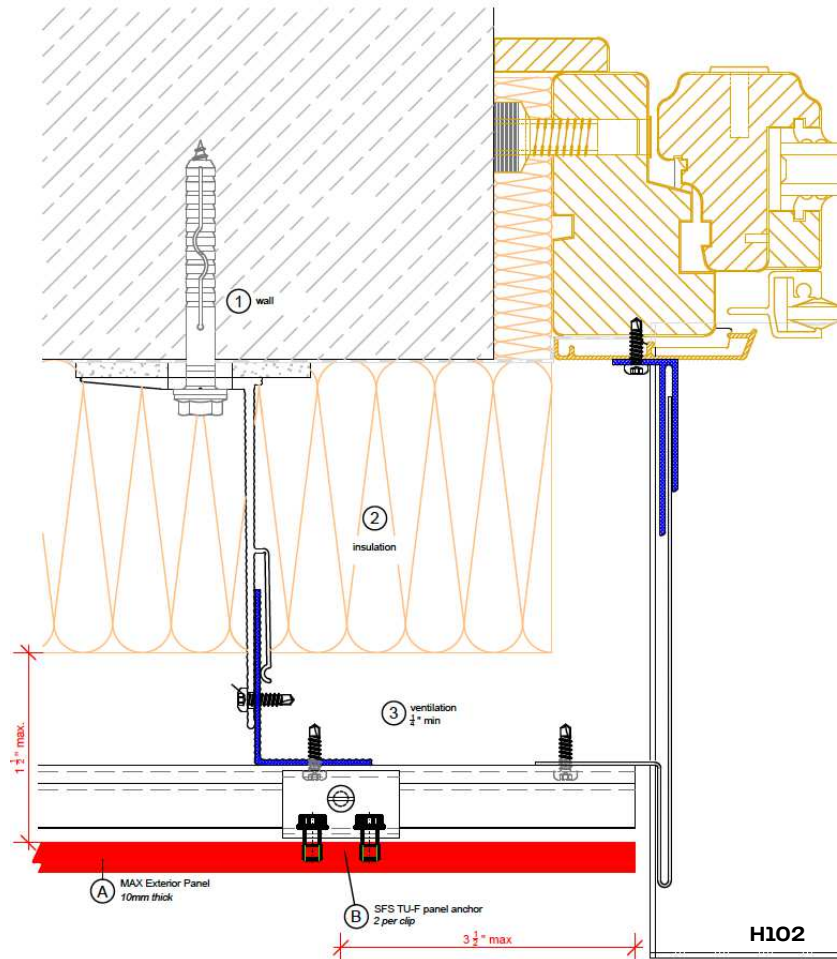

For full system details, please visit fundermax.us/system-details
 Fundermax 10mm Concealed Fastener Installations are NFPA285 compliant when installed per our Intertek CCRR Report, details at <https://spec-direct.intertek.com/controls/SDDocumentViewer.aspx?ccrr-CCRR-0527>

Construction Details – Concealed Fastening

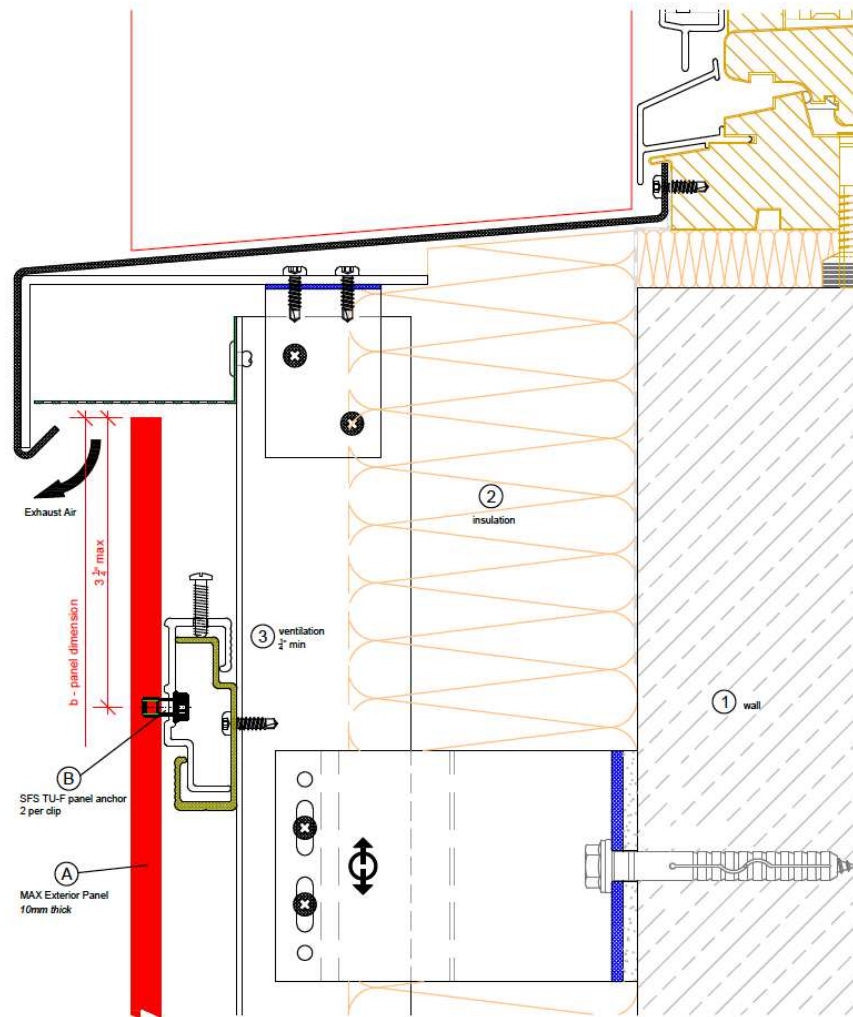

V104

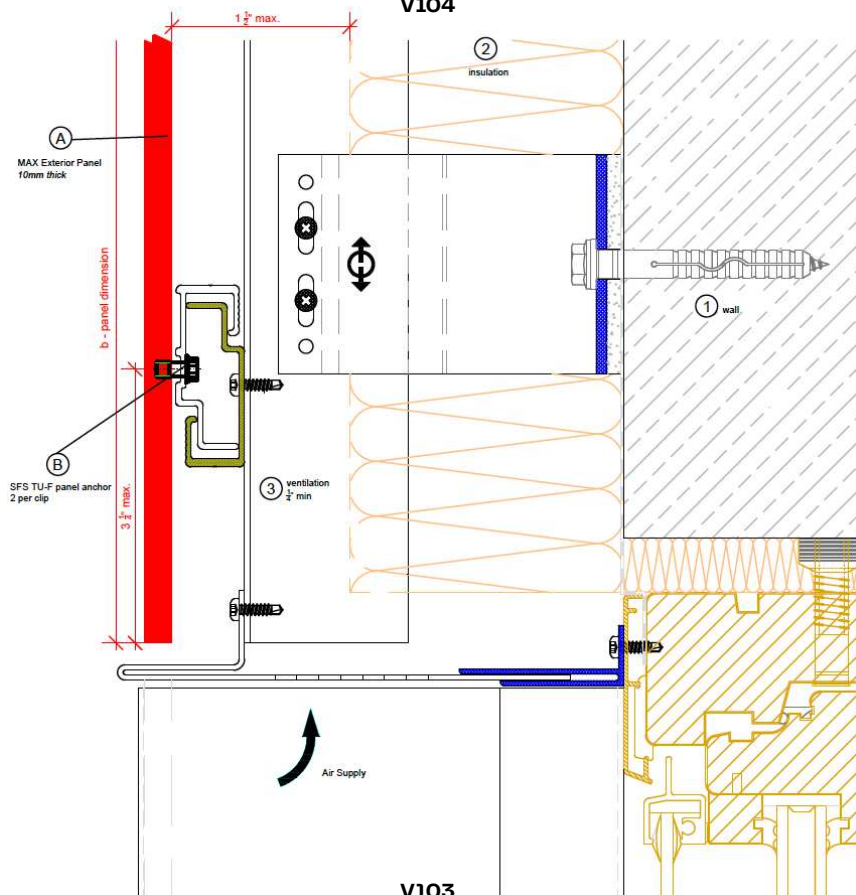

V103

Construction Details – Concealed Fastening

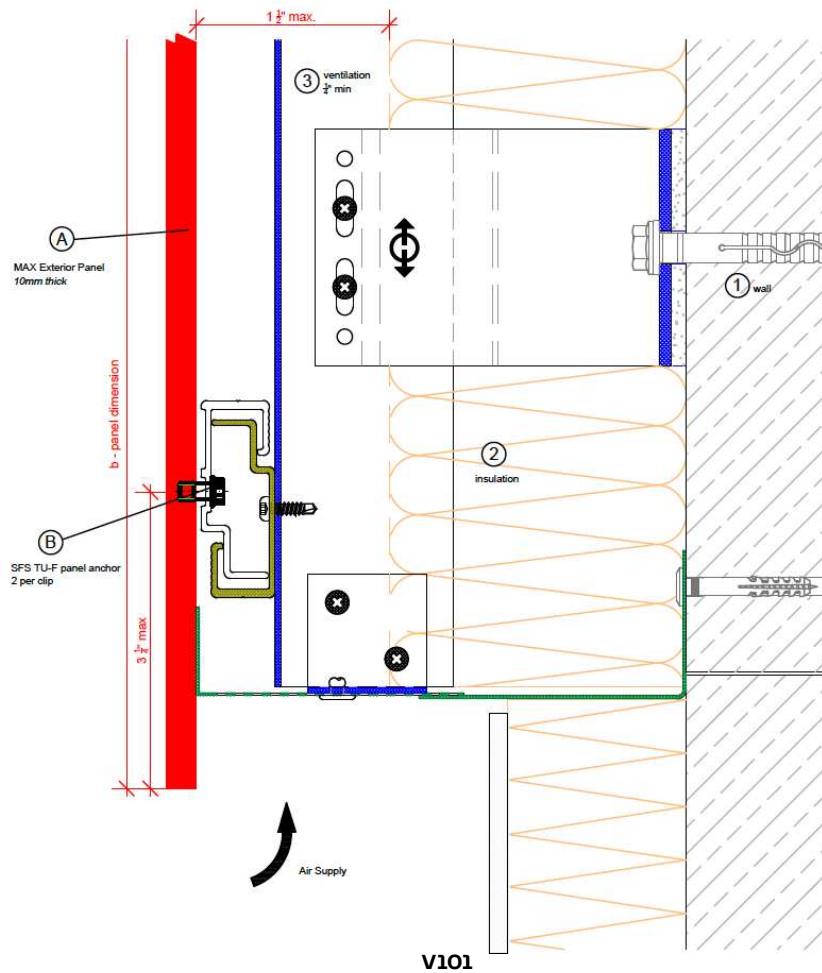
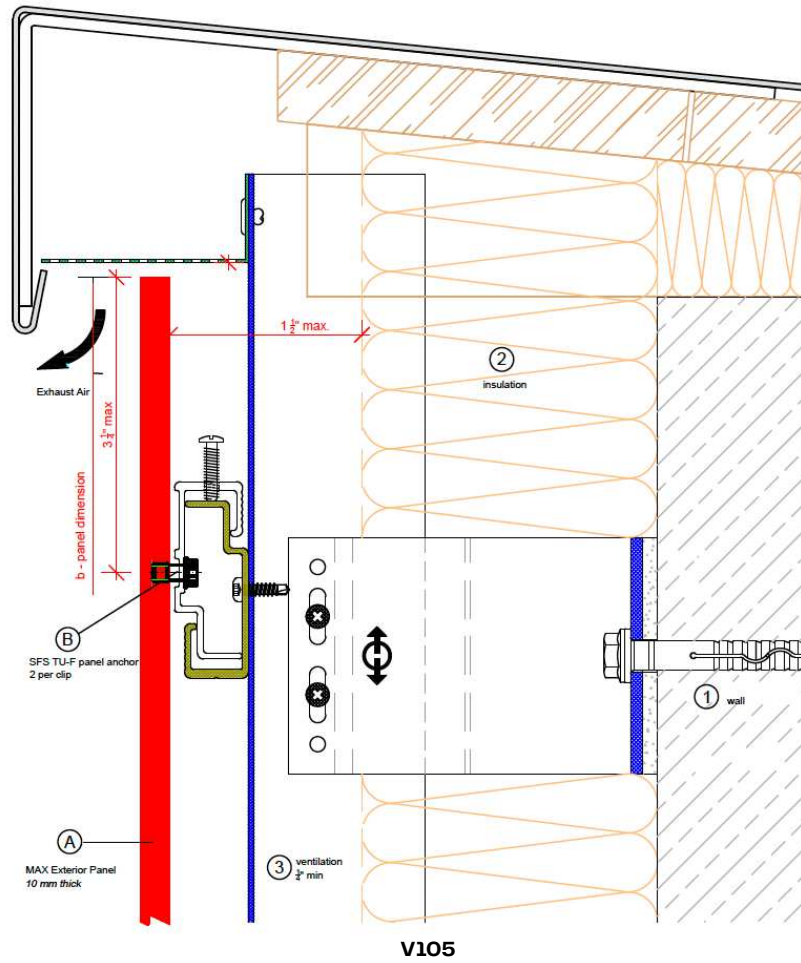

MODULO: The concealed fastener, closed joint modern façade system from Fundermax

For complete Modulo information and installation guidelines, please see our Modulo brochure at fundermax.us/brochures

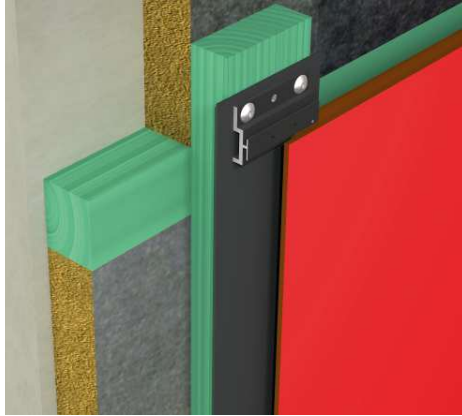

ADVANTAGES OF MODULO

- NFPA285 compliant assembly options
- Concealed fastening
- Closed joints
- Proven quality
- Abrasion resistant
- Impact and hail resistant
- Double-sided, balanced panels
- Weather resistant
- UV stable
- Ease of machining
- Ease of installation
- Minimal maintenance
- Ease of cleaning (non porous)
- Wide range of decors
- Quick ship program

NOTE

Custom panel heights between 6" and 24" available upon request.

MODULO FAÇADE SYSTEM

This modern façade fastening system with high design décor offerings makes it possible to install pre-fabricated panels on a concealed clip system. The panels can be installed in a stacked bond, running bond or a hybrid of both to create a façade with inspired visual interest. The substructure can be wood or aluminum, and can accommodate exterior insulation.

Note: Information about building regulation permits can be found at our website <https://fundermax.us/code-compliance-and-testing/>

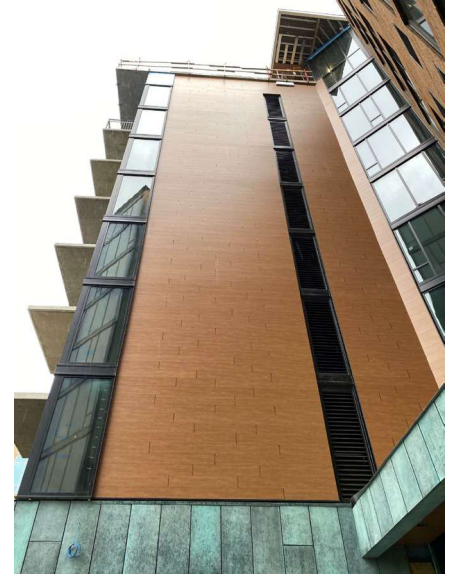

Design: Little Diversified Architectural Consultants, Durham
Download The Smoky Hollow Case study at fundermax.us/case-studies

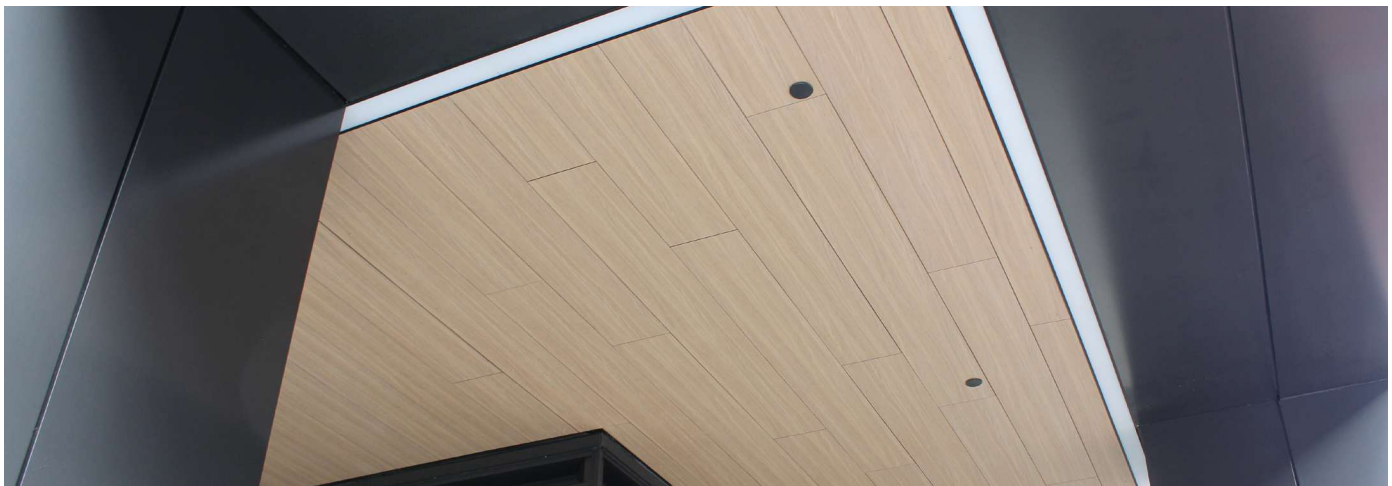

MODULO Technical Information

INFORMATION MODULO PANEL

MODULO 2X2

Format	24 x 24 in
Surface Coverage not including joint	23,92 x 23,92 in
Minimum order quantity = 1 package = 6 panels (or a multiple)	24 sf
Panel thickness	0,31 in
Surface coverage / package	23,82 sf
Surface coverage / panel	3,97 sf

MODULO 2X4

Format	48 x 24 in
Surface Coverage not including joint	47,92 x 23,92 in
Minimum order quantity = 1 package = 6 panels (or a multiple)	48 sf
Panel thickness	0,31 in
Surface coverage / package	47,7 sf
Surface coverage / panel	7,95 sf

PHYSICAL DATA/PROPERTIES

Artificial weathering EN ISO 4892-2	4-5
Fire Testing Data	Class A Rated per ASTM E84 See page 27 for more info

MODULO ACCESSORIES

Mounting clip	100 pcs/unit
Mounting track (L=118,11 in)	10 pcs/unit

LAYOUT PROCEDURES OF MODULO

By choosing this layout procedure – and the selection of the décor or varying decors – you have many design possibilities.

Note: The arrangement of sheet sizes can significantly influence time and effort required for the substructure. For joints lying vertically one atop the other, particularly careful work is necessary.

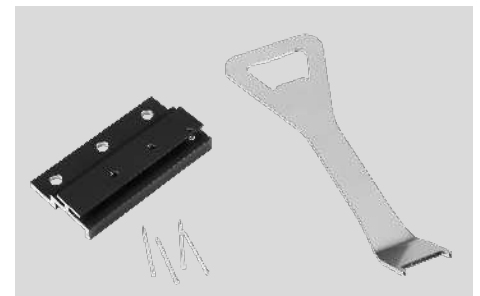

Accessories: fastener, locking pin, assembly aid

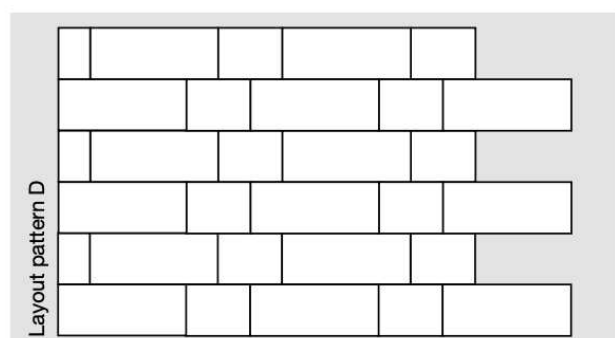
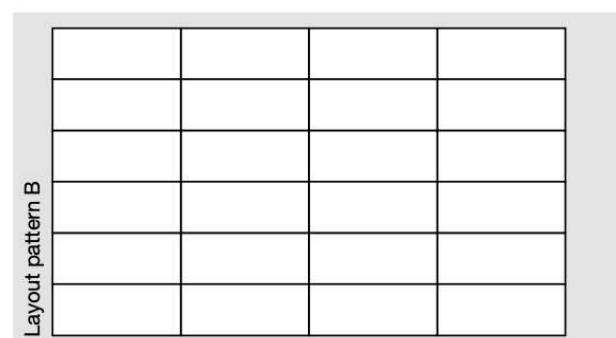
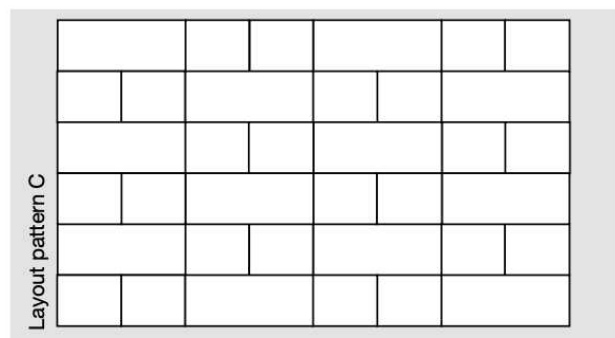
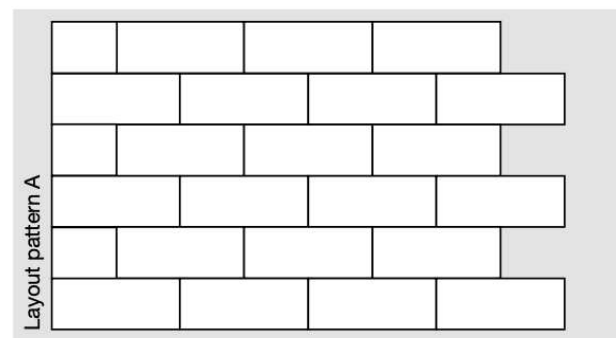

Modulo Technical Properties Datasheet

FUNDERMAX MAX COMPACT EXTERIOR, F QUALITY, NT SURFACE

PROPERTIES	TEST METHOD	STANDARD VALUE	
MECHANICAL PROPERTIES			
Panel Core		Standard Dark Brown Core, Finish on both sides	
Porosity		Non porous surface and edges	
Antimicrobial Characteristics		Fundermax panels do not support microorganic growth	
Modulus of Elasticity	property tested according to ES 438.2	≥ 9000 N/mm ²	≥ 1,305,340 psi
Tensile Strength	property tested according to ES 438.2	≥ 80 N/mm ²	≥ 11,603 psi
Flexural Strength	property tested according to ES 438.2	≥ 90 N/mm ²	≥ 13,053 psi
Density	Per EN ISO 1183-1	1.35 g/cm ³	1 N/mm ² = 1MPa
Surface Impact Resistance	Falling ball test per EN 438-2:21, (standard value = 10 mm)	≤ 10 mm	
Scratch Resistance	Per EN 438-2:25	4-6 N	4 N = .9 lbf
Abrasion Resistance	1 U = 1 cycle of rotation, property as tested per ES 438.2	≤ 450 U	
Color Stability – Artificial Weathering incl. Lightfastness	Per EN ISO 4892-2, industry standard = 3	Greyscale value 4-5	
Resistance to Fixings – Pullout Strength ISO 13894-1		≥ .3937 in	≥ 4000 N

PROPERTIES	TEST METHOD	STANDARD VALUE	
FIRE BEHAVIOR			
Burning Classification	As tested per ASTM E84	Class A rating	
PANEL THICKNESS			
8 mm			
FSI (Flame Spread Index)	As tested per ASTM E84	15	
SDI (Smoke Develop Index)	As tested per ASTM E84	70	

PROPERTIES	TEST METHOD	STANDARD VALUE	
MECHANICAL PROPERTIES			
Thermal Conductivity		0.3 W/mK	
Water Vapor Diffusion Resistance		ca. 17.200 μ	
Dimensional Changes during climatic	Dimensional Stability per EN 438-2:17	I %	0.1
Changes, measured at elevated temperatures		Q %	0.25
Dimensional Tolerance of Nominal Sizes		(+10 mm / - 0 mm)	
Dimensional Tolerance of Thicknesses		+/- .5 mm	≤ 12 mm
Resistance to Chemicals	Fundermax panels are highly resistant to many chemicals, complete list available on request		
Ease of maintenance/Cleaning	Fundermax panels resist dirt, easily cleaned with common agents, complete list available		

NOTE
Values are average values.

- ASTM E84 – Class A Rating (FSI = 15, SDI = 70)
- ASTM D 1929 = Pass (Self Ignition Temperature Greater than 650 degrees Celsius)
- NFPA 268 – Surface Ignition Test = Pass
- NFPA 285 – Intermediate Scale Multi Story Apparatus Test = Pass*

This is an assembly test, for assemblies that are NFPA285 compliant. see details and notes for options.

For complete Modulo information and installation guidelines, please see our Modulo brochure at fundermax.us/brochures

Fundermax Modulo Installations are NFPA285 compliant when installed per our Intertek CCRR Report, details at <https://specdirect.intertek.com/controls/SDDocumentViewer.aspx?ccrr=CCRR-0527>

Basic Design of a MODULO Façade

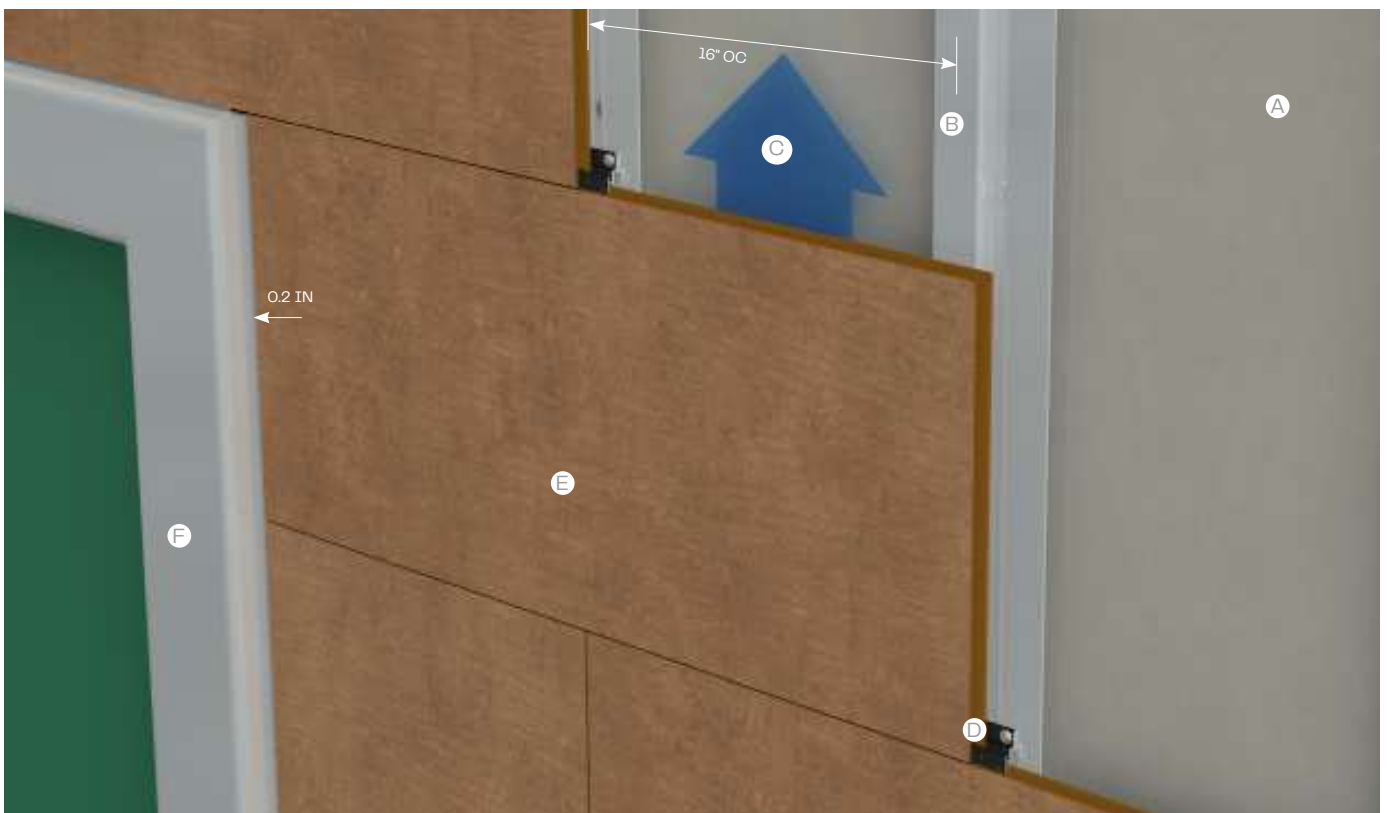

MODULO FAÇADE SYSTEM

LEGEND

- A Wall
- B Substructure
- C Ventilation
- D Mounting Clip
- E Modulo Element
- F Building elements like windows/
doors or wall sockets

Construction-details MODULO Façade System on aluminum-substructure

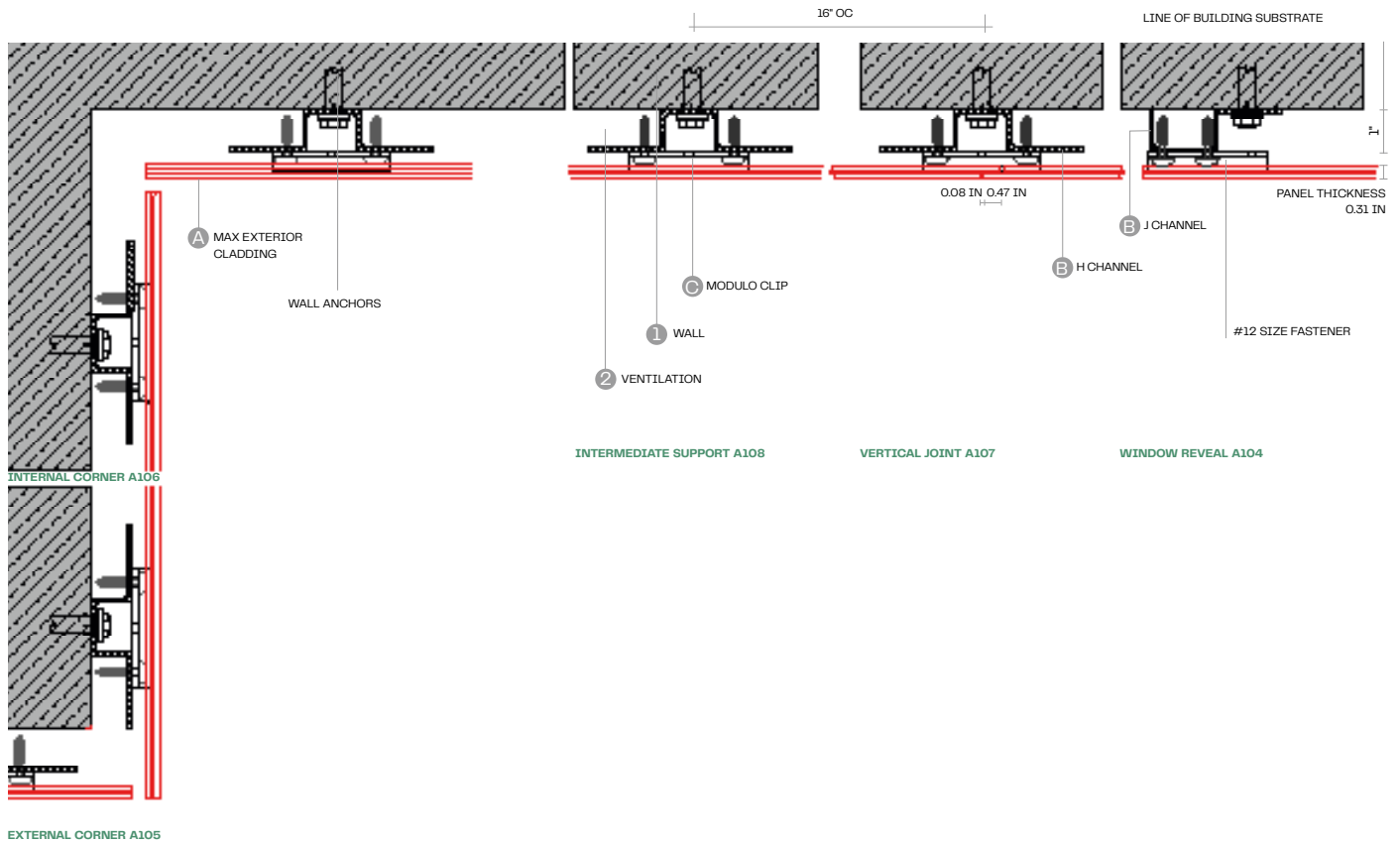

Construction-details MODULO Façade System on aluminum-substructure

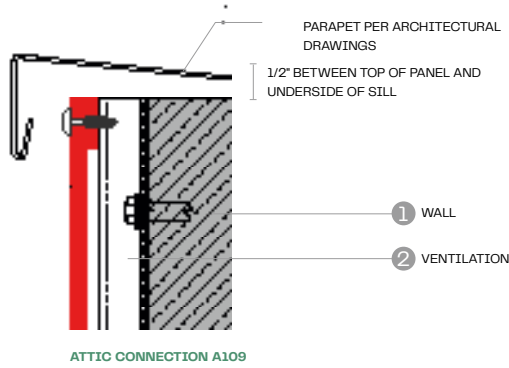

ATTIC CONNECTION A109

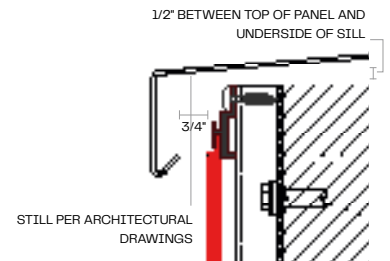
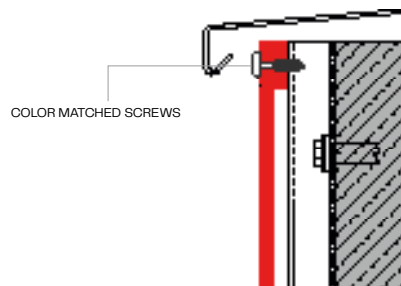

WINDOW SILL CONNECTION A102

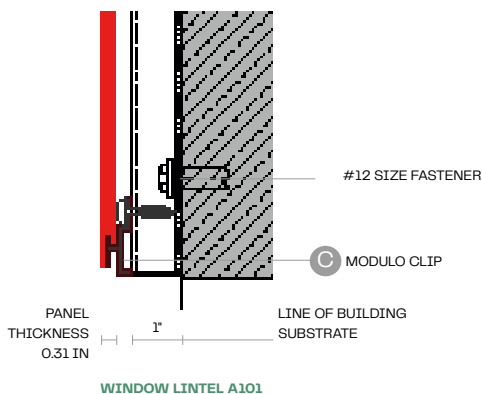

WINDOW LINTEL A101

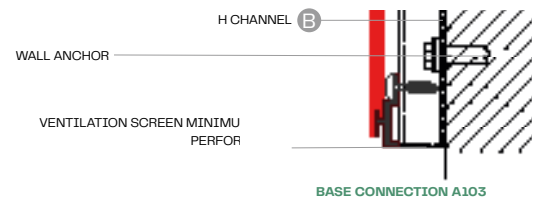

BASE CONNECTION A103

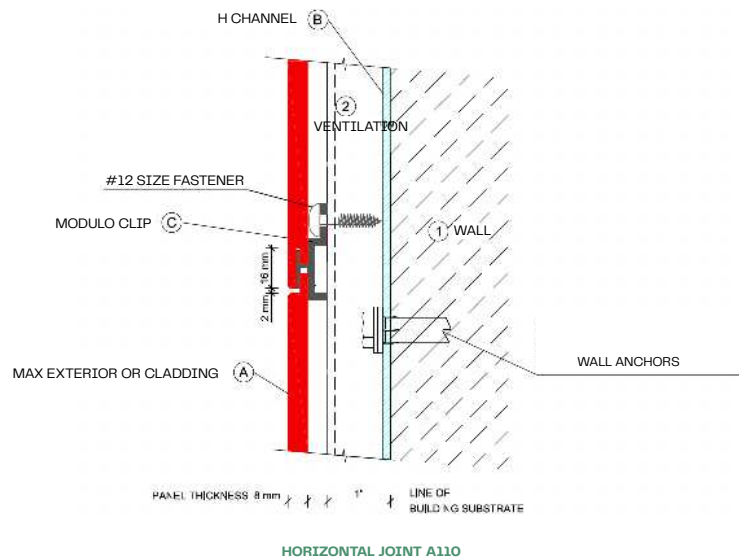

HORIZONTAL JOINT A110

NOTE

For full system details, please visit fundermax.us/system-details

Fundermax Modulo Installations are NFPA285 compliant when installed per our Intertek CCRR Report, details at <https://specdirect.intertek.com/controls/SDDocumentViewer.aspx?ccrr=CCRR-0527>

ALL THE SHOWN PROFILES AND FASTENINGS (EXCEPT THE FASTENING CLIP) ARE PLANNING SUGGESTIONS AND NOT PART OF THE Fundermax DELIVERY PROGRAMME.

All drawings in this brochure are not true to scale!

Fundermax Modulo Custom Sizing in Plank Formats

Fundermax Modulo can be manufactured and installed in plank formats within the following size range;

Minimum Height = 8"
Maximum Height = 24"
Any length is possible within
Fundermax's standard panel offering.

Joints on the long axis with the Modulo Machined Edge for clip installation will always be 2 mm.

Short Joints at panel to panel ends must be spaced per the following:

Panels 4-6 ft (1219 to 1829 mm) =
4 mm joint (5/32 in)

Panels 6-10 ft (1829 to 3048 mm) =
6 mm joint (1/4 in)

Panels 10 ft + (3048 mm +) =
8 mm joint (5/16 in)

Modulo Custom Sizes will come with Square cut ends and Modulo Grooves on each long edge for clip installation unless specified otherwise. Shipping with Square cut ends at the ends allows the panels to be field cut to length and can expedite the order process.

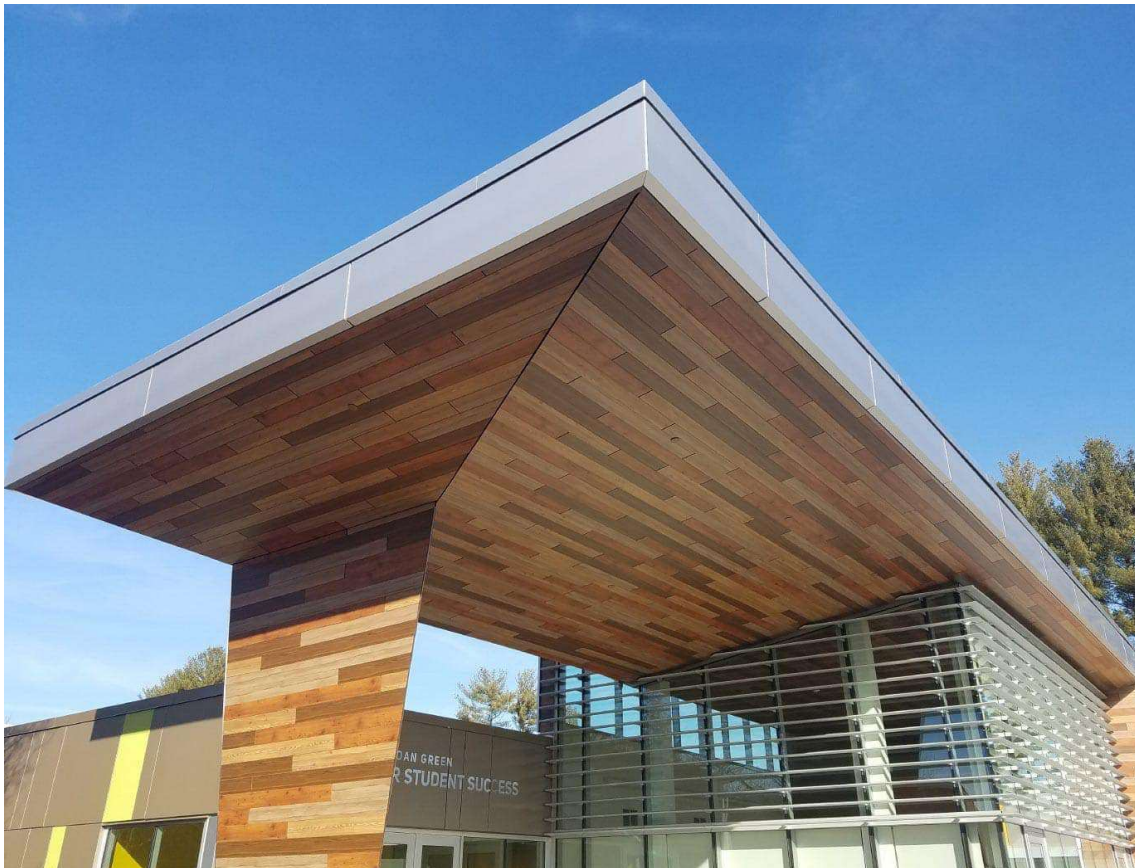

For complete Modulo information and installation guidelines, please see our Modulo brochure at fundermax.us/brochures

Fundermax Modulo Installations are NFPA285 compliant when installed per our Intertek CCRR Report, details at <https://specdirect.intertek.com/controls/SDDocumentViewer.aspx?ccrr=CCRR-0527>



SCALEO: A robust facade system with a perfect look

FUNDERMAX MAKES TRADITION EVEN BETTER

Pre-fabricated Max Exterior Panels for Scaleo Lap Siding make it easy to design and install robust and modern facades. With the engineered and easy to install mounting system, a façade of durable, UV resistant, and maintenance free Scaleo Lap Siding creates a beautiful and functional building exterior. The product characteristics make Scaleo Lap Siding a façade material with comprehensive protection. The double-hardened acrylic curing process provides a non-porous surface with tremendous abrasion resistance and UV stability. Scaleo Lap Siding is easy to clean and able to withstand the harshest of environmental conditions.

Note: For complete info including installation guidelines, please visit our website: fundermax.us

ADVANTAGES OF SCALEO

- Easy to mount (on wooden or aluminum substructure)
- Easy to clean
- Stock program for fast delivery
- Wide selection of decors
- Lightfast and UV-resistant
- Weather resistant
- Hail resistant
- Scratch resistant
- Pre-fabricated panels
- Double hardened surface



Scaleo

Fundermax Compact Exterior, F Quality, NT Surface 6mm Scaleo, Routed Edge Lap Siding System

FUNDERMAX MAX COMPACT EXTERIOR, F QUALITY, NT SURFACE

PROPERTIES	TEST METHOD	STANDARD VALUE	
MECHANICAL PROPERTIES			
Panel Core		Standard Dark Brown Core, Finish on both sides	
Porosity		Non Porous surface and edges	
Antimicrobial Characteristics		Fundermax panels do not support microorganic growth	
Modulus of Elasticity	property tested according to ES 438.2	≥ 9000 N/mm ²	≥ 1,305,340 psi
Tensile Strength	property tested according to ES 438.2	≥ 80 N/mm ²	≥ 11,603 psi
Flexural Strength	property tested according to ES 438.2	≥ 90 N/mm ²	≥ 13,053 psi
Density	Per EN ISO 1183-1	1.35 g/cm ³	1 N/mm ² = 1MPa
Surface Impact Resistance	Falling ball test per EN 438-2:21, (standard value ≤ 10 mm)	≤ 10 mm	
Scratch Resistance	Per EN 438-2:25	4-6 N	4 N = .9 lbf
Abrasion Resistance	1 U = 1 cycle of rotation, property as tested per ES 438.2	≤ 450 U	
Color Stability – Artificial Weathering inc. Lightfastness	Per EN ISO 4892-2, industry standard = 3	Greyscale value 4-5	

PROPERTIES	TEST METHOD	STANDARD VALUE	
FIRE BEHAVIOR			
Burning Classification	As tested per ASTM E84	Class A rating	
FSI (Flame Spread Index)	As tested per ASTM E84	10	
SDI (Smoke Develop Index)	As tested per ASTM E84	95	

PROPERTIES	TEST METHOD	STANDARD VALUE	
Maximum design pressure with vertical battens (panel attachments) at 16" centers		188 psf	
Maximum design pressure with vertical battens (panel attachments) at 24" centers		73 psf	

PROPERTIES	TEST METHOD	STANDARD VALUE	
MECHANICAL PROPERTIES			
Thermal Conductivity		0.3 W/mK	
Water Vapor Diffusion Resistance		ca. 17.200 μ	
Dimensional Changes during climatic	Dimensional Stability per EN 438-2:17	I %	0.1
Changes, measured at elevated temperatures		Q %	0.25
Dimensional Tolerance of Nominal Sizes		(+10 mm / - 0 mm)	
Dimensional Tolerance of Thicknesses		≤ 12 mm	+/- .5mm
Resistance to Chemicals	Fundermax panels are highly resistant to many chemicals, complete list available on request		
Ease of maintenance/Cleaning	Fundermax panels resist dirt, easily cleaned with common agents, complete list available		

USA: for IBC Construction Type I-IV buildings the Fundermax 6 mm lap siding system is for installed heights below 40' only. For Canadian applications please contact your local sales representative or visit our website at fundermax.us

For complete Scaleo information and installation guidelines, please see our Scaleo brochure at fundermax.us/brochures

Scaleo

Fundermax Compact Exterior, F Quality, NT Surface 6mm Scaleo, Routed Edge Lap Siding System

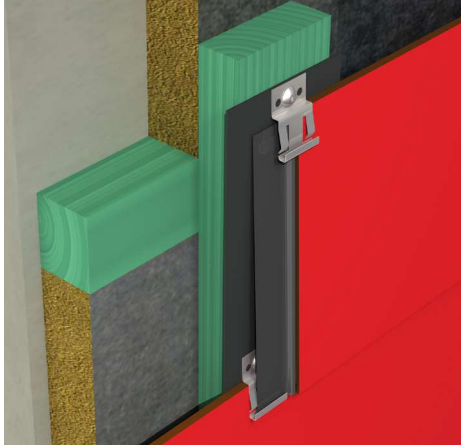

Scaleo provides an attractive system with prefabricated Max Exterior panels for lap siding. Our system is easy to design and use, and provides a robust and modern façade. Scaleo offers an ideal combination of ease of installation with the proven characteristics of Max Exterior façade panels.

Note: Information about building regulation permits can be found on our website at www.fundermax.us

ACCESSORIES AVAILABLE

- Mounting clips and instructions
- Vertical backing profile
- Inside and outside corner profiles

ADVANTAGES OF SCALEO LAP SIDING

- Proven quality
- Abrasion resistant
- Impact and hail resistant
- Double-sided, balanced panels
- Weather resistant
- UV stable
- Ease of machining
- Ease of installation
- Minimal maintenance
- Ease of cleaning (non porous)
- Wide range of decors
- Quick ship program

NOTE

Standard panel size for ease of installation: 110" x 9.84"
Custom heights between 6" and 12" available upon request

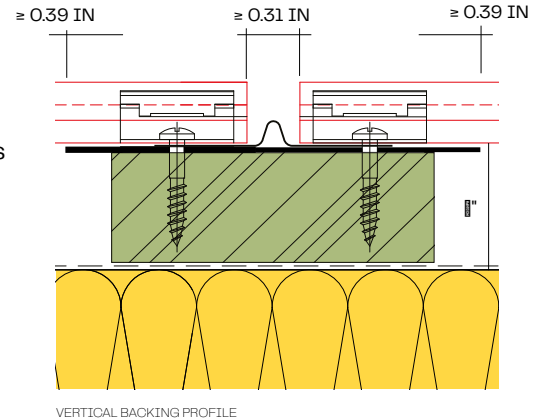

VERTICAL BACKING PROFILE

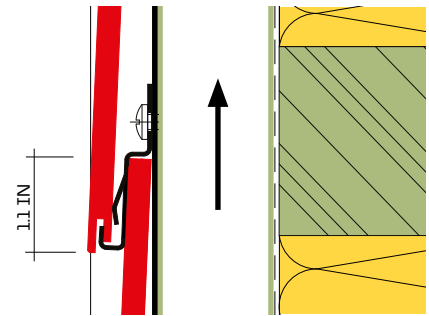

OVERLAP DIMENSION LAP-SIDING ELEMENTS

INFORMATION SCALEO PANEL

Format	110.24 x 9.84 in
Surface coverage	8.74 in
Minimum order quantity = 1 package = 5 panels (or a multiple)	37.67 sf
Panel thickness	0.24 in
Surface coverage / package	33.37 sf
Surface coverage / panel	6.67 sf

SCALEO ACCESSORIES

Mounting clips (approx. 10-12 clips/10 sf)	100 clips/unit
Vertical backing profile length = 9.69 in	10 pcs/unit
Vertical backing profile length = 98.43 in	20 pcs/unit

For complete Scaleo information and installation guidelines, please see our Scaleo brochure at fundermax.us/brochures

Construction-details SCALEO Façade System on wooden substructure

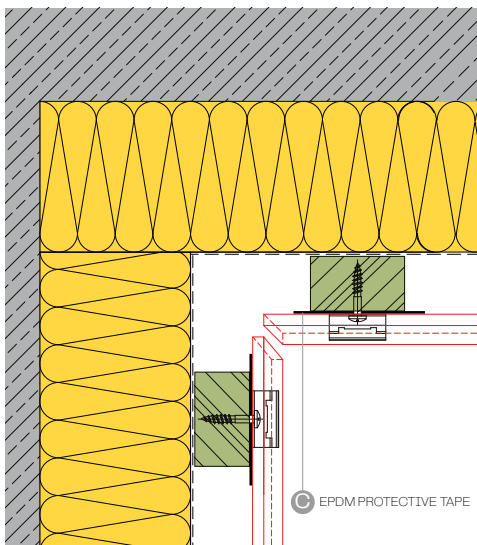

INTERNAL CORNER A106

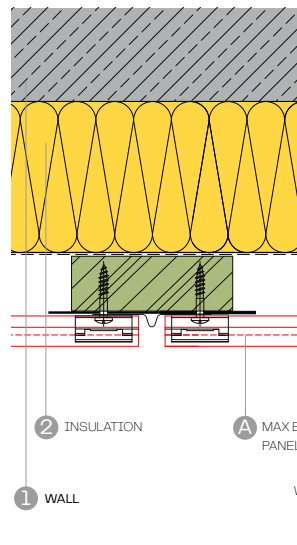

VERTICAL JOINT A107

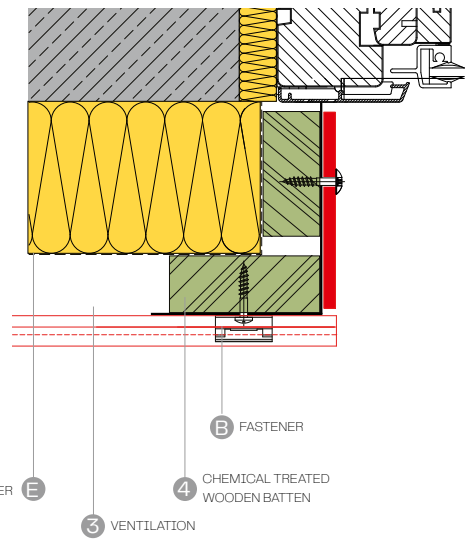

WINDOW REVEAL A104

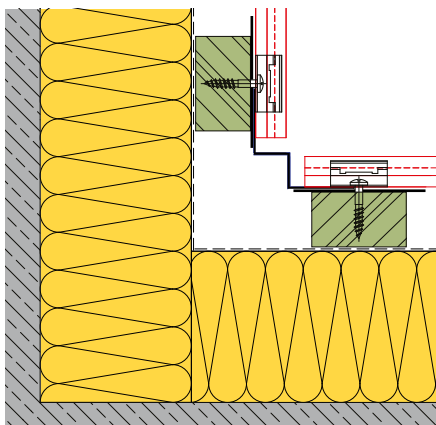

INTERNAL CORNER A106 WITH PROFILE

NOTE

Minimum 1.2 mm thick epdm tape is recommended on all wood substructure, returning back 3/8" on both sides. All shown profiles and fastenings (except the accessories mentioned on page 8) are planning-suggestions and not part of the fundermax delivery programme. All drawings in this brochure are not true to scale. CAD-details are available in the download section of the Fundermax website: www.Fundermax.us

NOTE

For complete info including installation guidelines, please visit fundermax.us



Construction-details SCALEO Façade System on wooden substructure

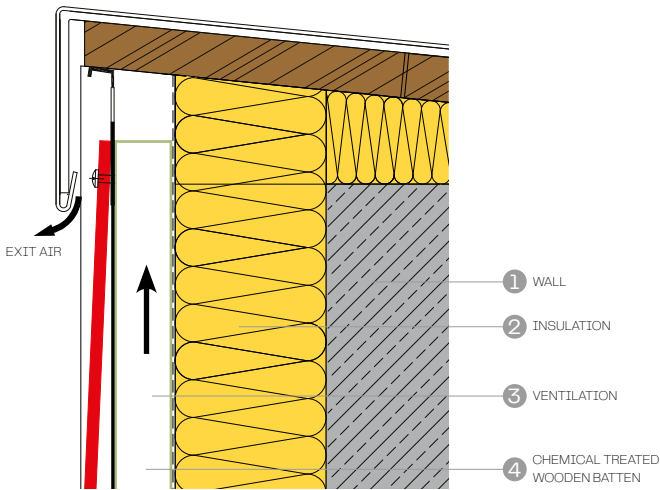

ATTIC CONNECTION A109

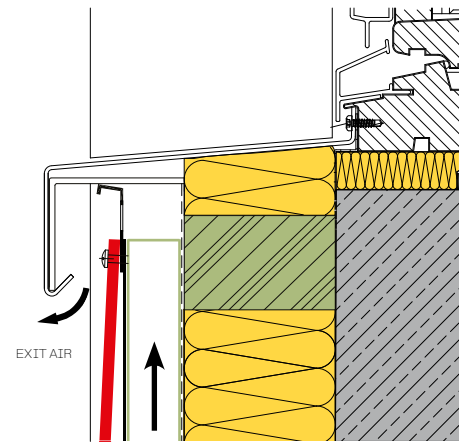

WINDOW SILL CONNECTION A102

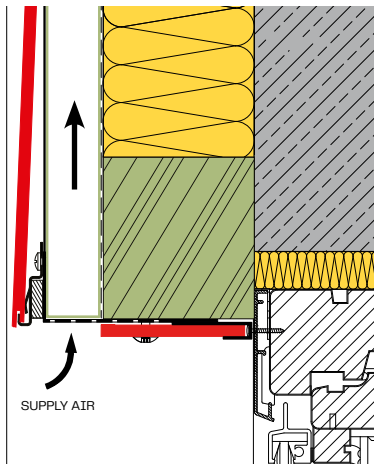

WINDOW LINTEL A101

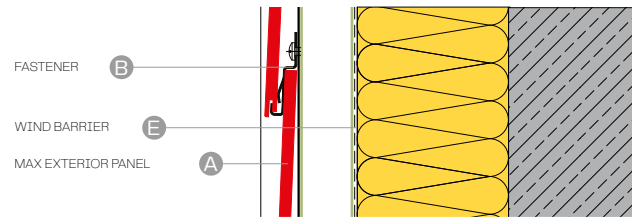

HORIZONTAL JOINT A110

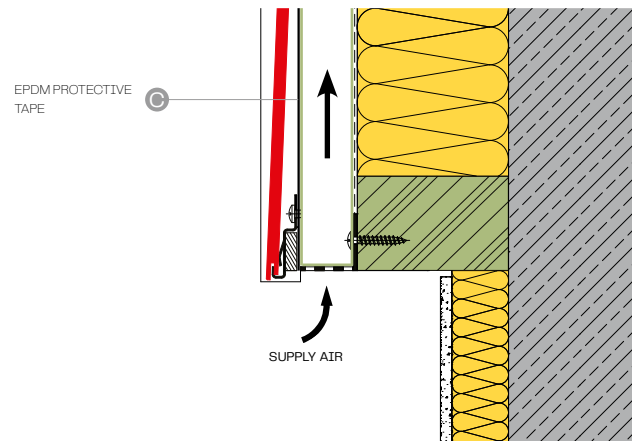

BASE CONNECTION A103



Panther Creek High School | Frisco, Texas



6 Soffits

“I think that it looks really great on our balcony. I think [the phenolic panels] really pop, and I think that it has elevated the design.”

(Caitlin Fedor, Smoky Hollow Project Architect)



Visible Mechanical Fastening with Rivets or Screws

Max Compact Exterior panels can be mounted on an aluminum substructure using rivets, on a timber substructure using screws, or using invisible mechanical fasteners. For timber substructures, please take note of national standards (moisture content of wood $15\% \pm 3$) and the need for construction-related or chemical timber protection. An EPDM membrane strip (thickness 1.2 mm) with a ≥ 10.0 mm overhang on all sides is required between the panel and wooden batten. Fit the batten parallel to the direction of air flow.

Clear air cross section for air inlets and outlets ≥ 20.0 mm. Outgoing air goes out through the rear ventilation space of the rainscreen facade. Fixed and sliding points should be designed into the installation of Max Compact Exterior panels.

Fixed Point

Fixed points serve to evenly distribute (halve) changes in size. The diameter of drill holes in Max Compact Exterior panels corresponds with the diameter of the fastener.

Notes

NG surface: For the best possible look, installation using an aluminum substructure is recommended to avoid a wavy overall appearance. For suppliers, see end of the brochure.

Sliding Point

The diameter of the drill hole in the Max Compact Exterior panel must be larger than the diameter of the fastener, depending on the required expansion clearance. The diameter of the drill hole is the shaft diameter of the fastener plus 2.0 mm per meter of cladding material starting from the fixed point. The fastener head must cover the drill hole. Attach fasteners so the panel can move. Do not screw them in too tight. The center of the hole in the substructure must match the center of the hole in the panel. Use a drilling jig. Start fastening the panels at the center of the panel and work outward.

Distance from Edge

Maintain a distance from the edge of 20.0–80.0 mm ($3/4'' - 3 1/4''$) to ensure stability and flatness. For dimensional changes, panel joints should be at least 8.0 mm (see Fig. 6 02).

Fastener Spacing

Observe relevant structural requirements. If this is not necessary due to local building regulations, see the table on page 75 for values.

Fasteners

Only use fasteners made out of non-corrosive materials.

Fasteners: SFS TW S D13 (metal substructure)
SFS TWS D12 (wood substructure)
SFS AP16 Rivet (metal substructure)

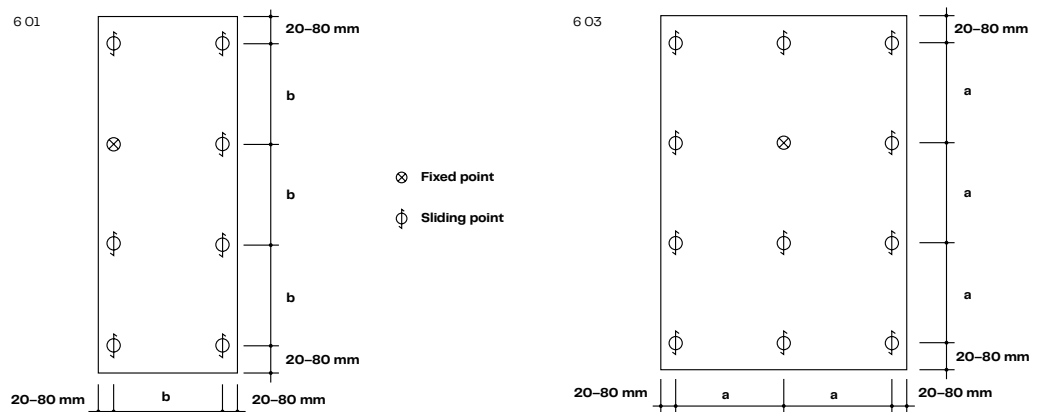
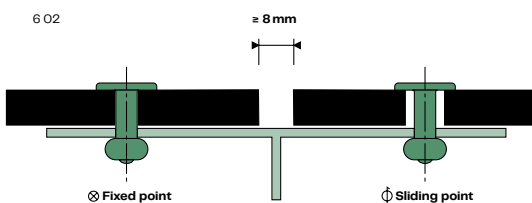

Horizontal Applications on Soffits – Wind Load

Panel Thickness:		8 mm					
No. of Fasteners		Wind Pressure (psf)					
		25	30	35	40	45	50
1 into J-shaped alum. extrusion	x-spacing (in)	32	32	32	32	32	32
	y-spacing (in)	22.9	19.4	16.8	14.8	13.2	12.0
	x-spacing (in)	24	24	24	24	24	24
	y-spacing (in)	30.5	25.8	22.3	19.7	17.6	15.9
	x-spacing (in)	16	16	16	16	16	16
	y-spacing (in)	39.6	38.0	33.5	29.6	26.4	23.9
1 with 1" min pen. into SPF wood	x-spacing (in)	32	32	32	32	32	32
	y-spacing (in)	11.4	9.6	8.4	7.4	6.6	6.0
	x-spacing (in)	24	24	24	24	24	24
	y-spacing (in)	15.2	12.9	11.1	9.8	8.8	7.9
	x-spacing (in)	16	16	16	16	16	16
	y-spacing (in)	22.8	19.3	16.7	14.7	13.2	11.9

Panel Thickness:		10 mm					
No. of Fasteners		Wind Pressure (psf)					
		25	30	35	40	45	50
1 into J-shaped alum. extrusion	x-spacing (in)	32	32	32	32	32	32
	y-spacing (in)	22.4	19.0	16.5	14.6	13.1	11.8
	x-spacing (in)	24	24	24	24	24	24
	y-spacing (in)	29.9	25.3	22.0	19.4	17.4	15.8
	x-spacing (in)	16	16	16	16	16	16
	y-spacing (in)	44.8	38.0	33.0	29.2	26.1	23.7
1 with 1" min pen. into SPF wood	x-spacing (in)	32	32	32	32	32	32
	y-spacing (in)	11.2	9.5	8.2	7.3	6.5	5.9
	x-spacing (in)	24	24	24	24	24	24
	y-spacing (in)	14.9	12.6	11.0	9.7	8.7	7.9
	x-spacing (in)	16	16	16	16	16	16
	y-spacing (in)	22.3	18.9	16.4	14.5	13.0	11.8

Note:

1. Chart utilizes AAMA TIR-A9-91 (2000 Addendum) Table 41 for the allowable pullout of #12 screw into 6063-T5 1/8" aluminum.
2. Chart utilizes TW-S-D12 Pan Head 304 Austenitic Stainless Steel self-tapping fasteners with a minimum 1" full wood penetration.
3. Wood is assumed to be spruce-pine-fir species.
4. Connection of vertical J-extrusion or wood batten to substrate beyond must be engineered by others.
5. These are design pressure guidelines only and not a substitute for project specific engineering calculations.

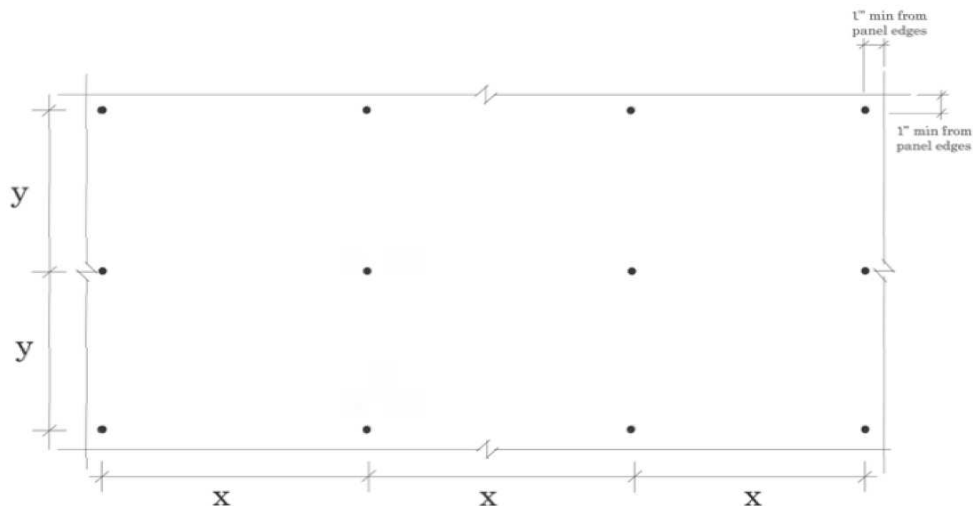

7 Outdoor Furniture

“Great design shouldn’t be hidden away inside.”

(Philippa I., interior designer)



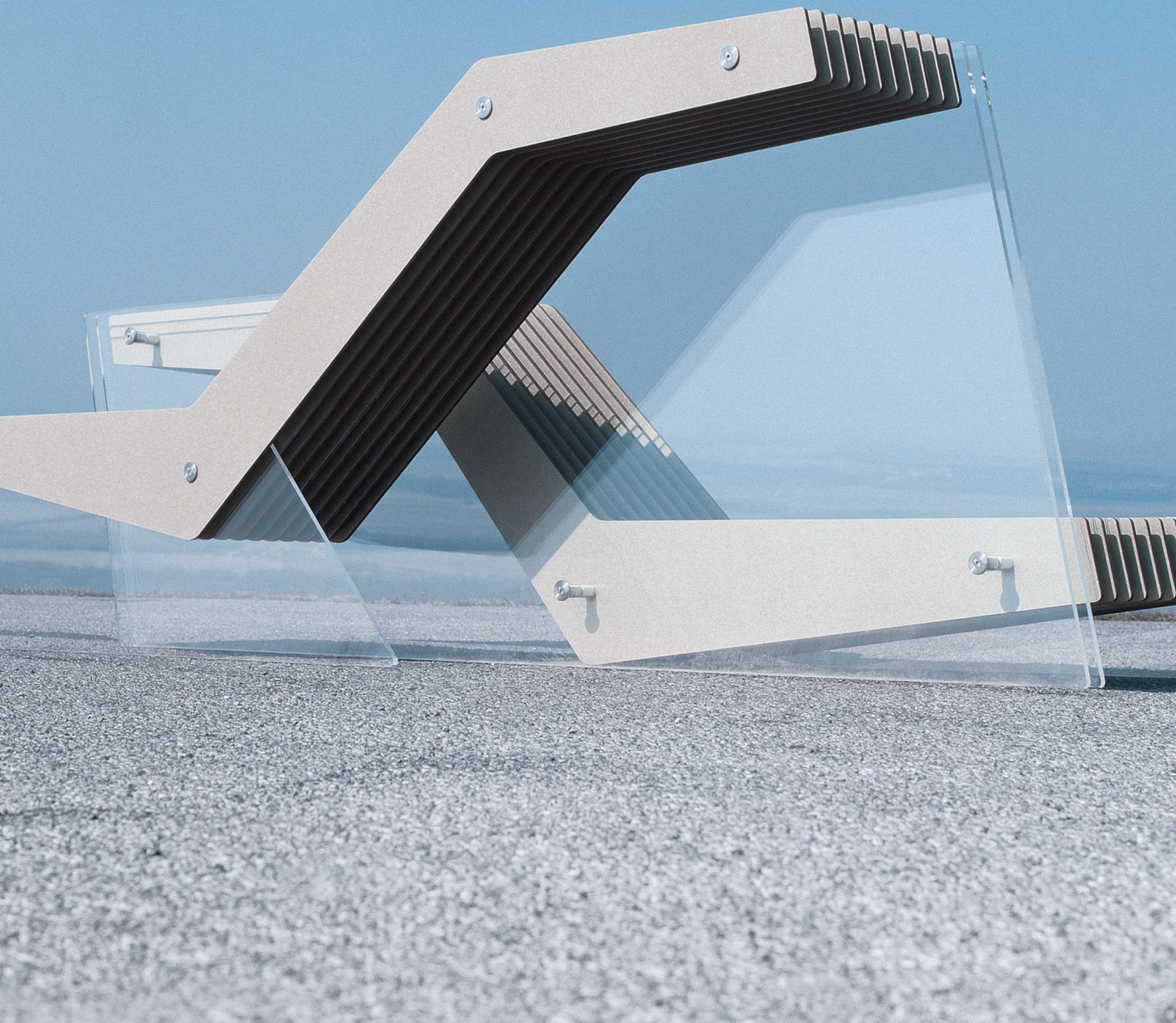

Recommendation for Manufacturing Outdoor Furniture

Application

Max Compact Exterior panels are suitable for use as table tops, benches, or other furniture for outdoor use.

Resistance

The panels have non-porous surfaces, good chemical resistance (easy to clean), and are highly resistant to scratches, abrasion, and impacts.

Storage

Due to their weight, tables should not be stacked, nor should table tops be stored one on top of the other. Protect outdoor furniture from standing water in winter.

Panel Thickness

The panel thickness should be 12.0 mm, or a minimum of 10.0 mm, to provide sufficient depth for screws. The panel thickness, fastener spacing, and expected load capacity are directly linked and should be calculated accordingly.

Installation

Ensure that the installation is unrestricted. Fasten using screws or glue. Screws can be screwed either directly into the panel or via sleeves with external and internal threads (e.g., Rampa sleeves). For this, the panels must be drilled one size smaller to establish a thread. Panels are fastened using screws from the underside. Screws with a metric thread and a flat head are suitable—do not use countersunk screws. If necessary, washers can be used. Only use fasteners made out of non-corrosive materials. Create fastening points as sliding points.

Fastener Spacing

Max Compact Exterior

Thickness (mm)	Fastener spacing (mm)	Overhang (mm)
10.0	320.0	180.0
12.0	400.0	250.0

Sliding Points

Depending on the expansion clearance required, the diameter of the drill hole in the substructure should be larger than the diameter of the fasteners. The screw head should cover the drill hole. Position the fasteners so that the panel can move. The center of the hole in the substructure must match that of the hole in the Max Compact Exterior panel. Drill with a centering aid! Start fastening the panels at the center of the panel and work outward.

7 01

Sliding point

Sliding point

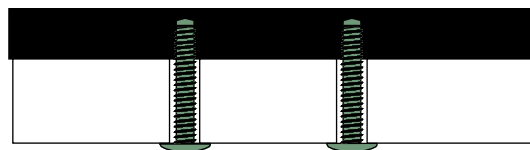

Examples when Using Max Compact Exterior Panels of 12.0 mm

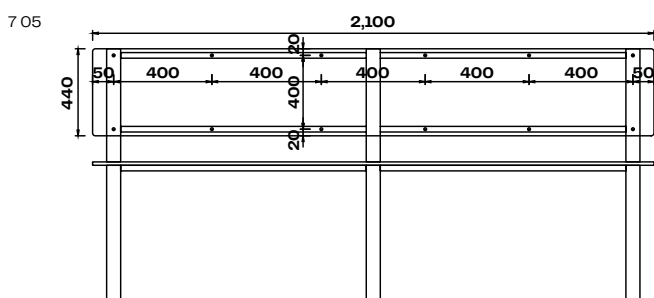
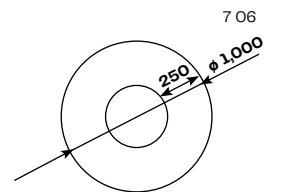
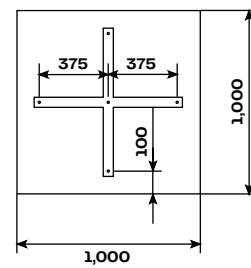
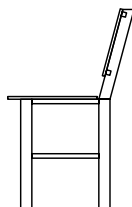
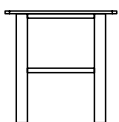
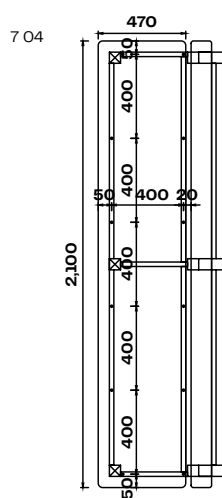
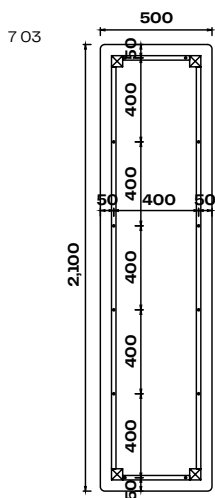
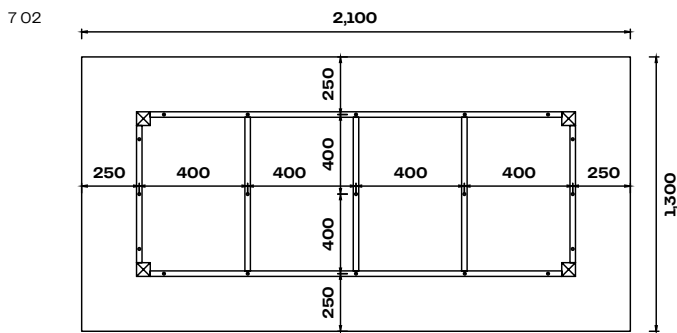

- 7 01 Sliding points
- 7 02 Table application
- 7 03 Bench
- 7 04 Bench with backrest
- 7 05 Bench with backrest
- 7 06 Table top overhangs

8 Balconies and Railings



**“Balconies are details.
But it’s the details that
make the design.”**

(Jonas G., contractor)



General

Max Compact Exterior panels can be fitted in a variety of versions as balcony and railing fillings or fences.

Basics

Protect the material from standing water (panels must be able to dry out). Bonded Max Compact Exterior panels should always be joined in the same running direction. Variations in flatness (see EN 438-6, 5.3) can be offset by stable, level construction of the substructure. All joints with other building elements or the subsurface should be securely closed. Avoid any flexible intermediate layers with the substructure structure and parts of the substructure that have a tolerance of more than ± 0.5 mm. Max Compact Exterior panels can be installed using rivets or screws. Form fixed and sliding points when installing panels (see Fig. 8 01 and Fig 8 02, page 83).

Technical Notes

Protect the substructure from corrosion. Be aware of preventing possible contact corrosion when selecting materials. Anchoring elements for affixing to brickwork/concrete or for installing panels must be specified in accordance with typical local wind loads and structural requirements. Evidence of this must be provided by the client. When installing panels, take into account the required expansion clearance according to manufacturer's recommendations.

Sliding Point

The diameter of the drill hole in the Max Compact Exterior panel must be larger than the diameter of the fastener, depending on the required expansion clearance. Shaft diameter of the fastener plus 2.0 mm per meter of cladding material starting from the fixed point. The fastener head must cover the drill hole. Set fasteners so that the panel can move. Position rivets centrally using a flexible mouthpiece. The spacing of the rivet heads on the surface of the panel (0.3 mm) allows for movement of the parts in the drill hole (see Fig. 8 01 and Fig. 8 02, page 83).

The center of the drill hole in the substructure should match the one on the Max Compact Exterior panel—use a drilling jig! Start fastening the panels at the center of the panel and work outward.

Fixed Point

Fixed points serve to evenly distribute (halve) changes in size. The diameter of the drill hole in the Max Compact Exterior panel should be the same size as the diameter of the fastener.

Panel Joints

To ensure that dimensional changes can be made without restriction, make sure joints are at least 8.0 mm wide (see Fig. 8 03, page 83).

Combining Decorative Finishes

For a consistently light design for balcony interiors, Max Compact Exterior panels can also be made with a white (reverse) side (O890 NT – Balcony White). The combination of different decorative laminates means the specified mounting distances should be reduced by at least 15%.

Balcony Corners

For renovations involving very uneven substructures in particular, it is important for the front panel to protrude about 10.0 mm in front of the side panel. That will cover the construction tolerances of the main visible sides (see Fig. 8 04).

8 01

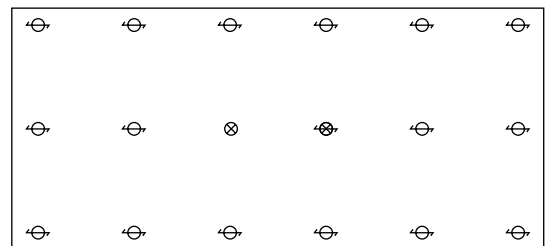

8 02

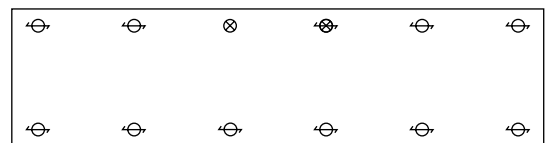

- ⊗ Fixed point
- ⊕ Sliding point
- ⊕ Expansion point

8 03

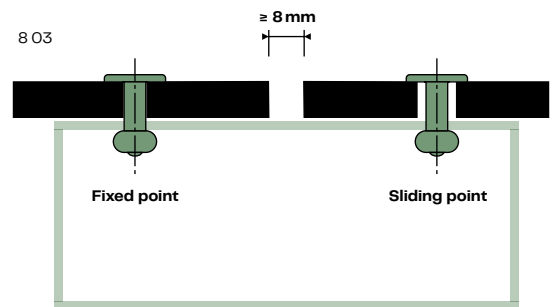

8 04

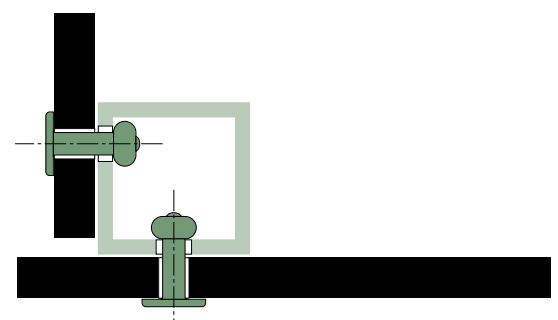

Balcony Fasteners

As a basic principle, only use fasteners made out of non-corrosive materials.

Fasteners: SFS TW S D13 (metal substructure)
 SFS TWS D12 (wood substructure)
 SFS AP16 Rivet (metal substructure)

Glass clamp holder:

Can also be used for installation. Apply one lock pin per panel element (protects against falling by easing the clamping on the panels).

Apply rivets using a flexible mouthpiece (0.3 mm allowance).

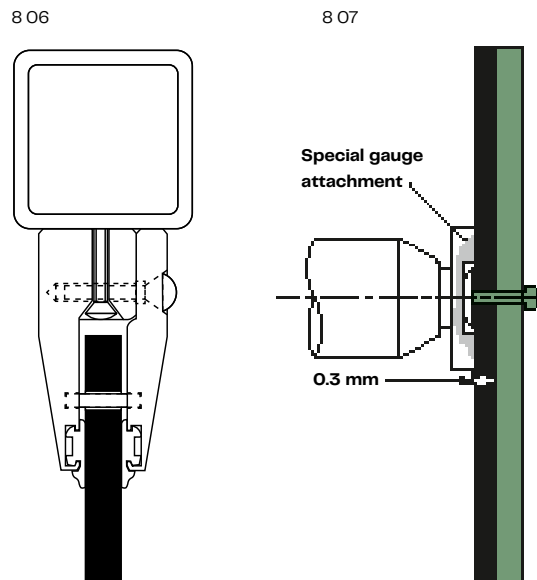
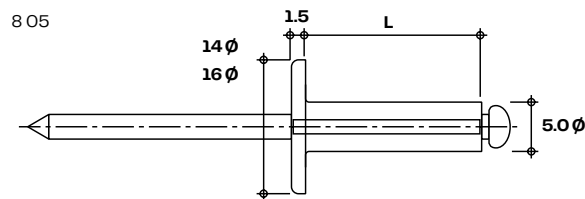

8 05 Blind rivet with large head
 8 06 Glass clamp holder



Simphonia WOA Beiramar in Brazil



The Lodnareal Passive Apartment Building in Austria



Smart Living Apartments in Vienna

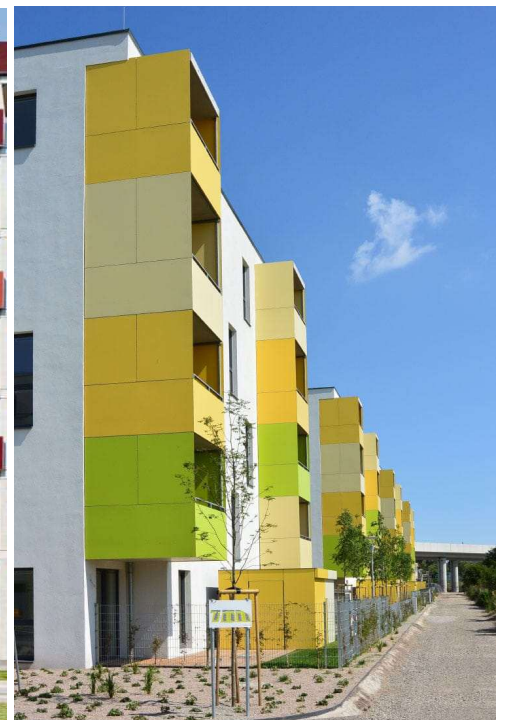

Passive Residential Neighborhood in Vienna

Fastening and Edge Distance Options

Riveted Max Compact Exterior Panel (Riveted Version)

The railing installation options shown here were tested by MPA Hannover in accordance with ETB guidelines for securing components against falls, July 1985 edition* and passed.

$F1 \leq 120.0 \text{ mm}$ (approx. 4 3/4")

$F2 \leq 40.0 \text{ mm}$ (approx. 1 5/8")

Clear overhangs E1:

- For 8.0 mm panels: 20.0 mm (approx. 3/4") $\leq E1 \leq 200.0 \text{ mm}$ (approx. 8")
- For 10.0 mm panels: 20.0 mm (approx. 3/4") $\leq E1 \leq 250.0 \text{ mm}$ (approx. 10")

Clear overhangs E2:

- For 8.0 to 10.0 mm panels: 20.0 mm (approx. 3/4") $\leq E2 \leq 80.0 \text{ mm}$ (approx. 3 1/4")

Panel thickness	Railing height* $H = 900.0 - 1,100.0 \text{ mm}$ (approx. 35 1/2" - 43 1/4") = max. fastener spacing
8.0 mm	A $\leq 350.0 \text{ mm}$ (approx. 13 3/4")
	L $\leq 950.0 \text{ mm}$ (approx. 37 3/8")
10.0 mm	A $\leq 400.0 \text{ mm}$ (approx. 16")
	L $\leq 1,000.0 \text{ mm}$ (approx. 39 1/2")

* Set railing height according to local building regulations, e.g., OIB guideline 4 – Safety in use and accessibility. High safety barrier: min. 100.0 cm, from a fall height of over 12.0 m (measured from the floor) min. 110.0 cm.



8 08

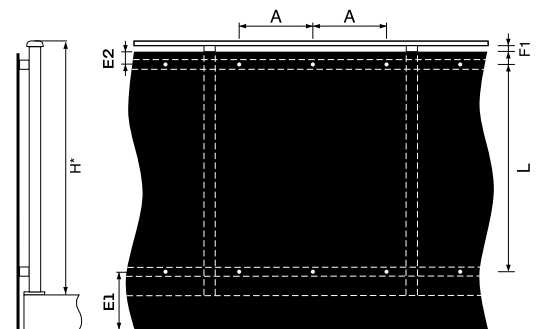

8 09

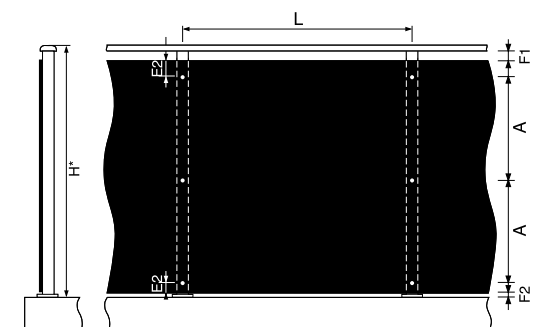

Screwed Max Compact Exterior Panel (Balcony Screw)

F1 ≤ 120.0 mm (approx. 4 3/4")

F2 ≤ 40.0 mm (approx. 1 5/8")

Clear overhangs E1:

- For 8.0 mm panels: 20.0 mm (approx. 3/4") ≤ E1 ≤ 200.0 mm (approx. 8")
- For 10.0 mm panels: 20.0 mm (approx. 3/4") ≤ E1 ≤ 250.0 mm (approx. 10")

Clear overhangs E2:

- For 8.0 to 10.0 mm panels: 20.0 mm (approx. 3/4") ≤ E2 ≤ 80.0 mm (approx. 3 1/4")



8 10

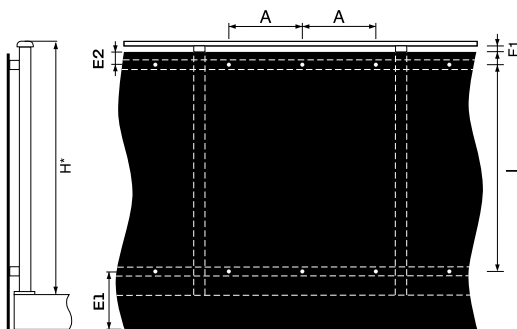

Panel thickness	Railing height*	
	H = 900.0–1,100.0 mm (approx. 35 1/2" – 43 1/4") = max. fastener spacing	
8.0 mm	A	≤ 500.0 mm (approx. 20")
	L	≤ 1,000.0 mm (approx. 39 1/2")
10.0 mm	A	≤ 550.0 mm (approx. 21 3/4")
	L	≤ 1,100.0 mm (approx. 43 1/4")

* Set railing height according to local building regulations, e.g. OIB guideline 4 – Safety in use and accessibility. High safety barrier: min. 100.0 cm, from a fall height of over 12.0 m (measured from the floor) min. 110.0 cm.

8 11

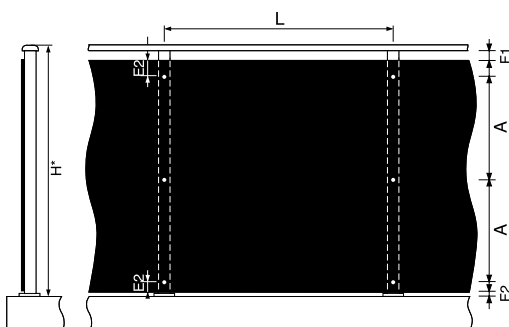

- 8 08 Horizontal rivet fastening
- 8 09 Vertical rivet fastening
- 8 10 Horizontal balcony screw fastening
- 8 11 Vertical balcony screw fastening

Max Compact Exterior Panels with Aluminum Frames—Attached, Dimensions According to Structural Requirements

- F1 ≤ 120.0 mm (approx. 4 3/4")
- F2 ≤ 40.0 mm (approx. 1 5/8")
- B ≥ 1,300.0 mm (approx. 1 5/8") = part length
- P ≥ 28.0 mm (approx. 1 1/8") internal profile depth
- D ≥ 8.0 mm (approx. 5/16") expansion leeway

Ensure the profiles can drain and prevent waterlogging.

Panel thickness	Railing height* H = 900.0–1,100.0 mm (approx. 35 1/2" – 43 1/4") = max. fastener spacing
8.0 mm	A ≤ 1,150.0 mm (approx. 45 1/4")

* Set railing height according to local building regulations, e.g., OIB guideline 4 – Safety in use and accessibility. High safety barrier: min. 100.0 cm, from a fall height of over 12.0 m (measured from the floor) min. 110.0 cm.



8 12

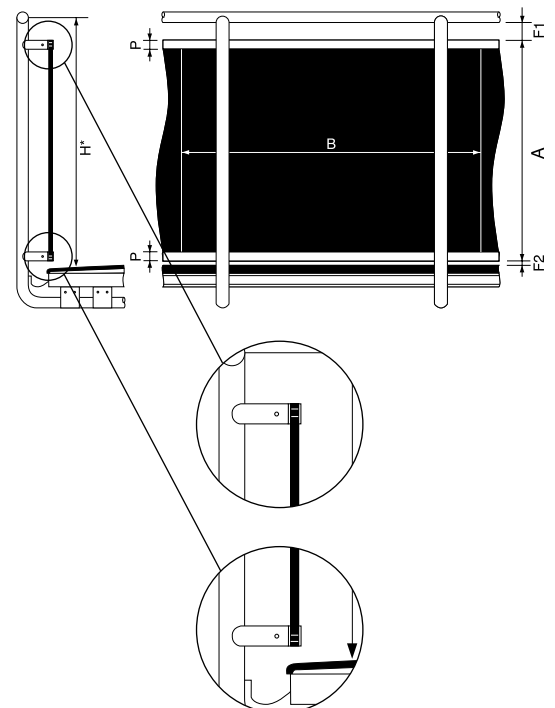

Perforated Max Compact Exterior Panels Exposed Fasteners

Arrange center distances in a square pitch (see Fig. 8 18).

F1 \leq 120.0 mm (approx. 4 3/4")

F2 \leq 40.0 mm (approx. 1 5/8")

Clear overhangs E1:

- For 10.0 mm panels: 20.0 mm (approx. 3/4") \leq E1 \leq 250.0 mm (approx. 10")

Clear overhangs E2:

- For 10.0 mm panels: 20.0 mm (approx. 3/4") \leq E2 \leq 80.0 mm (approx. 3 1/4")

Panel thickness	Railing height* H = 900.0–1,100.0 mm (approx. 35 1/2" – 43 1/4") = max. fastener spacing	
	10.0 mm	A \leq 350.0 mm (approx. 13 3/4")

* Set railing height according to local building regulations, e.g., OIB guideline 4 – Safety in use and accessibility. High safety barrier: min. 100.0 cm, from a fall height of over 12.0 m (measured from the floor) min. 110.0 cm.

Example hole pattern

D	Diameter	\leq 40.0 mm (approx. 1 5/8")
G	Hole spacing	min. 30.0 mm (approx. 1 1/4")
H	Hole center spacing	min. 70.0 mm (approx. 2 3/4")

8 13

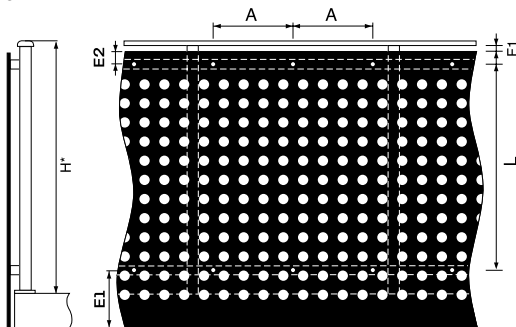

8 14

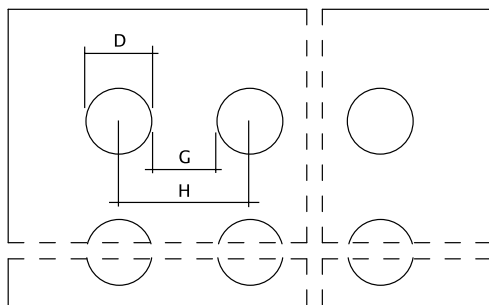

- 8 12 Fastening using frames
- 8 13 Fastening using rivets / perforated Max Compact Exterior panel
- 8 14 Recommended hole pattern

See perforation guidelines on page 92



Max Compact Exterior Panels Attached Using Clamping

Profiles (Glass Holders)

$F1 \leq 120.0$ mm (approx. 4 3/4")

$F2 \leq 40.0$ mm (approx. 1 5/8")

$G \leq 35.0$ mm (approx. 1 3/8")

Clear overhangs E1:

- For 8.0 mm panels: 20.0 mm (approx. 3/4") $\leq E1 \leq 160.0$ mm (approx. 6 1/4")

- For 10.0 mm panels: 20.0 mm (approx. 3/4") $\leq E1 \leq 200.0$ mm (approx. 8")

Clear overhangs E2:

- For 8.0 to 10.0 mm panels: 20.0 mm (approx. 3/4") $\leq E2 \leq 80.0$ mm (approx. 3 1/4")

Arrange min. three (3) fastening points per side. Apply one clamp holder with a lock pin per panel element.

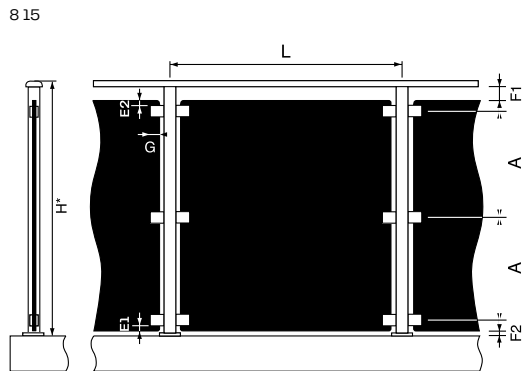

Panel thickness	Railing height* H = 900.0–1,100.0 mm (approx. 35 1/2" - 43 1/4") = max. fastener spacing	
	8.0 mm	A
L		≤ 950.0 mm (approx. 37 3/8")
10.0 mm	A	≤ 500.0 mm (approx. 20")
	L	$\leq 1,100.0$ mm (approx. 43 1/4")
13.0 mm	A	≤ 550.0 mm (approx. 21 3/4")
	L	$\leq 1,150.0$ mm (approx. 45 1/4")

* Set railing height according to local building regulations, e.g. OIB guideline 4 – Safety in use and accessibility. High safety barrier: min. 100.0 cm, from a fall height of over 12.0 m (measured from the floor) min. 110.0 cm.



Balcony with glass holders

Balcony Divider Panels

General

Max Compact Exterior divider panels are used to partition off individual sections of elongated balconies or passageways. The panels are placed perpendicular to the outer wall of the building and affixed in a variety of ways. Depending on the design of the outer edge of the balcony surface, the panels extend to the lower edge of the ceiling of the next story down in the building. Affix to continuous profiles or plates. Design the hollow substructure according to structural calculations and affix to the reinforced concrete slabs using approved anchor bolts or other mounting parts. Profiles must act as structurally load-bearing supports. Max Compact Exterior F panels should be fastened with the same fasteners as railing panels. Privacy screen elements must be attached via at least three (3) fastening points on each side.

Clear overhangs E:

- 10.0 mm panels: $20.0 \text{ mm (approx. } 3/4\text{")} \leq E \leq 80.0 \text{ mm (approx. } 3 \text{ } 1/4\text{")}$
- $F \geq 8.0 \text{ mm (approx. } 5/16\text{")}$
- $G: 20.0\text{--}30.0 \text{ mm (approx. } 3/4\text{ - } 1 \text{ } 1/4\text{")}$

Notes

Make sure you opt for different fastener spacings if the balcony divider panels are being used as a fall protection. You will find these in the "Balconies and Railings" section.

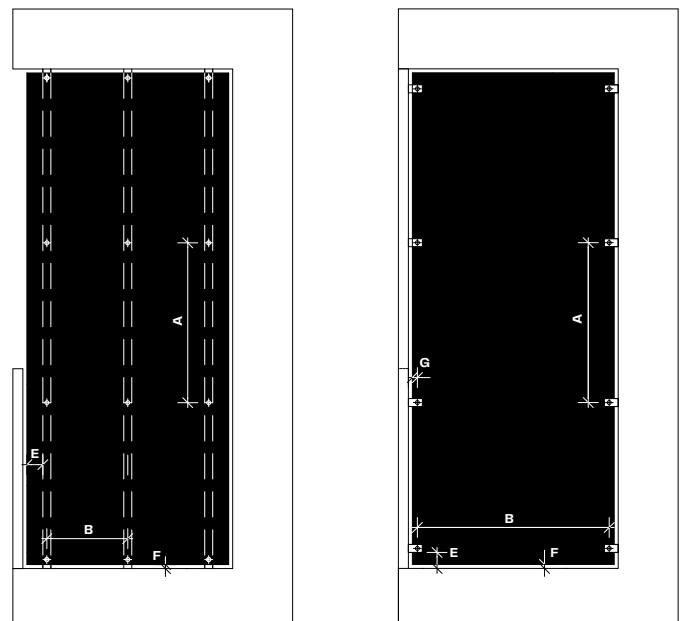

9 Perforation Guidelines



“Discovering Fundermax allowed us to do and design in ways that we didn’t think of before.”

(Chris Peterson, AIA,
D.C. Bilingual Project Architect)



Perforation Guidelines

Perforation Guidelines Max Exterior

Our general recommendations for perforating Fundermax Compact Panels:

- Distance from the edge to the panel to the first machined area minimum 60mm
- Distance between the perforations, minimum 30mm
- Spacing between holes should be at least 1.5X the diameter of the hole
- No 90 degree edges at any machined out areas A minimum radius of 5mm at every edge or corner
- Around the fixing points for rivets or screws you will need minimum a space of 40mm diameter without any material removed.
- All edges on perforations should have a chamfer of 1 or 2mm
- Over 20% perforation will decrease the stability of the panel and may require reduced fastening distances
- When possible, perforations should be kept to 30% or less open area
- All patterns must be approved by the Fundermax Machining Center
- All perforated Fundermax panels are subject to review and approval by the Project Engineer

We will gladly review your CAD drawings for any application when considering perforation. Our state of the art CNC Processing Center can make your vision into a reality!



Science and Engineering Wing at The Park School of Baltimore | Product: Max Compact Exterior | Decor: Amazon #0922 NT | Photo Credit: Hord Coplan Macht (HCM) | Architect: Hord Coplan Macht (HCM)

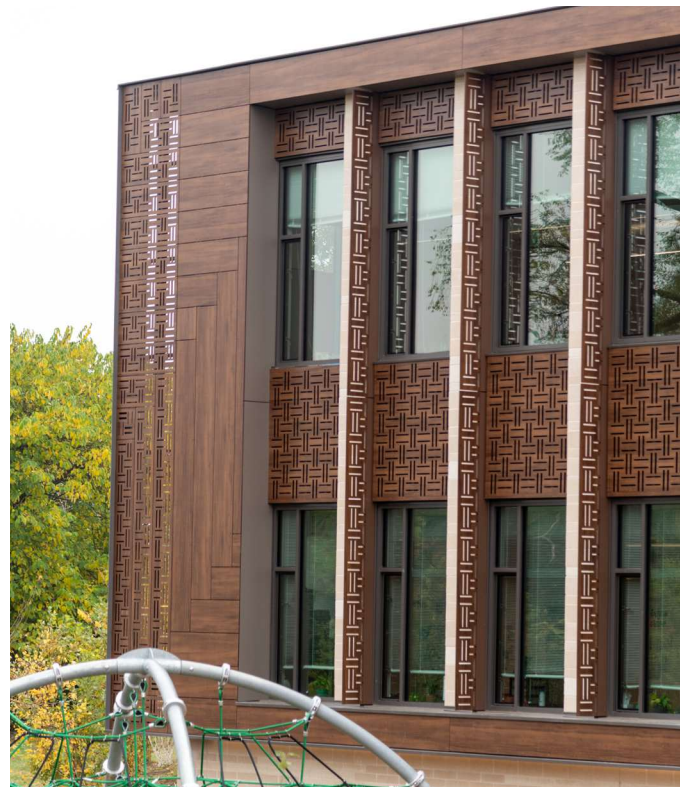

D.C. Bilingual Public Charter School | Product: Max Compact Exterior | Decor: Amazon #0922 NT | Photo Credit: PPSI | Architect: Hord Coplan Macht (HCM)



10 Podio Balcony Floor Panels





**“Quality is always
the best foundation.”**

(Patricia Z., practice manager)

Podio (Max Compact Exterior) Balcony Floor Panels

Description of Materials

This balcony floor panel is a high-quality construction product bearing the CE label and a non-slip hexagon surface, suitable for balconies, steps, and platforms.

Max Compact Exterior panels are thermoset high-pressure laminates (HPL) that meet the requirements of EN 438-6, type EDF, and offer effective weather protection thanks to double hardened acrylic polyurethane resin. They are produced in laminate compactors at a high temperature and pressure.

Surfaces

- Top: NH-Hexa
- Underside: NT

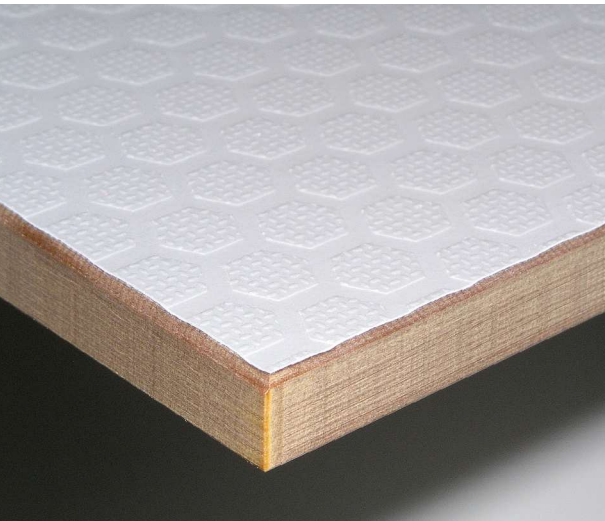

Decorative Laminates

Two-sided: See current Max Compact Exterior collection or www.fundermax.com

Anti-Slip Gradings

- R10 in accordance with DIN 51130
- Group C in accordance with DIN 51097

Fundermax Anti Slip Certification may be seen at <https://fundermax.us/code-compliance-and-testing/>

Sizes

- XL = 4,100 (approx. 161 3/8") x 1,854 mm (approx. 73") = 7.6 m² (approx. 81.82 ft²)
- X2 = 2,050 (approx. 80 11/16") x 1,854 mm (approx. 73") = 3.8 m² (approx. 40.9 ft²)
- GR = 2,800 (approx. 110 1/4") x 1,300 mm (approx. 51 3/16") = 3.64 m² (approx. 39.18 ft²)
- GR sizes = 2,800.0 x 1,300.0 mm = 3.64 m² and X2 = 2,050.0 x 1,854.0 mm = 3.8 m² are only available in 6 stock colors.
- Tolerances +10.0–0.0 mm (EN 438-6, 5.3)
- Panel sizes are standard sizes. For dimensional and angle accuracy, cutting all sides is recommended. Depending on the cut, the net measurement reduces by approx. 10.0 mm.

Core

- F-Quality, flame retardant, brown color

Thicknesses (According to Structural Requirements)

Thickness	Tolerance (EN 438-6, 5.3)
• 16.0 mm	± 0.7 mm
• 18.0 mm	± 0.7 mm
• 20.0 mm	± 0.7 mm

Local building regulations must be observed. For horizontal installation only.

Note: For full Podio information please visit the website at fundermax.us/ brochures

10 01

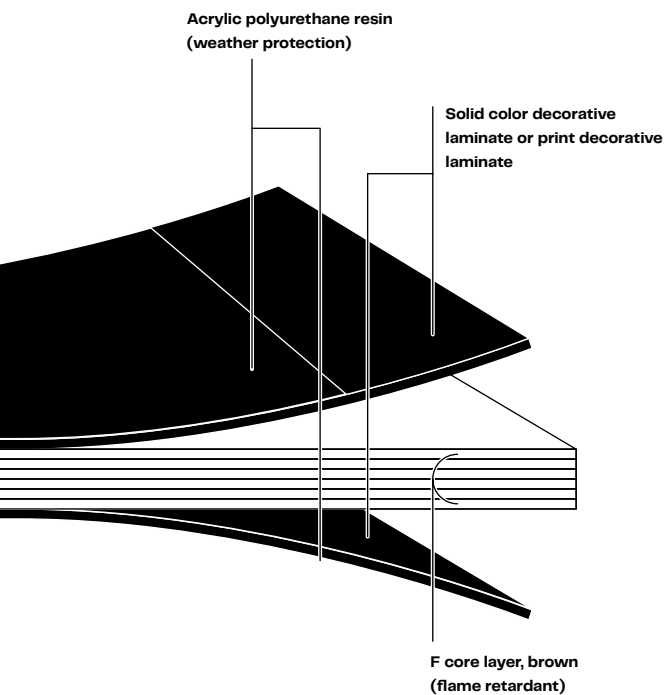

10 01 Composition of balcony floor panels
10 02 Vertical cross section—principle of rear ventilation and gradient

Basics of Handling

Podio balcony floor panels can be attached to suitable substructures in various ways, with gradients, using screws or adhesive. The subsurface and substructure need to be structurally capable of supporting sufficient load. Make sure there is rear ventilation with a minimum 1" gap above the subsurface. Moisture-retaining subsurfaces (grass, gravel, shingle, etc.) are unsuitable. Ensure there is enough drainage in the subsurface.

Protect material from standing water—panels must be able to dry out. In general, balconies should have a gradient of $\geq 2\%$. Ensure a suitable amount of expansion clearance. Panel joints must be a at least 8.0 mm. For substructures that run parallel to butt joints, arrange panel joints over the substructure and possibly keep them on the same level using suitable connections. Avoid any flexible intermediate layers with the substructure, and between the parts of the substructure that have a tolerance of more than ± 0.5 mm.

When affixing to substructure using screws, use fixed and sliding points (see Fig. 5 03 and Fig. 5 04 on page 36).

Make sure there is appropriate rear ventilation to condition the panels on both sides. Refrain from laying the full surface on the subsurface. Protect the substructure from corrosion.

10 02

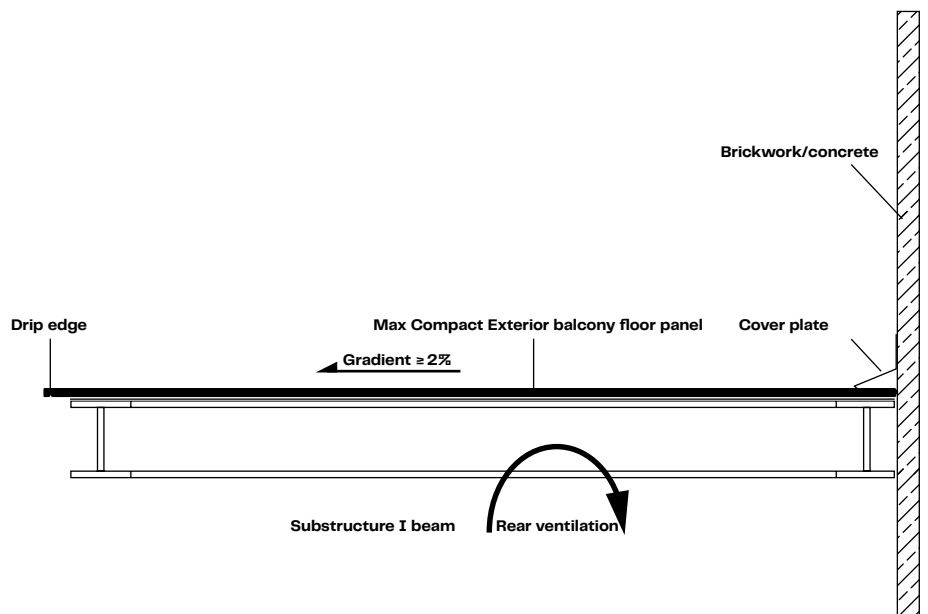
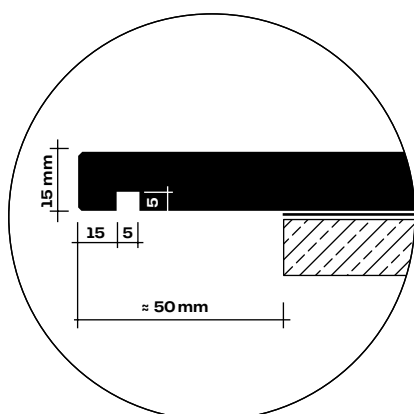

Installation Guidelines

Fastener Spacing

Substructure strips must have a width of ≥ 60.0 mm (approx. 2 3/8"), or ≥ 80.0 mm (approx. 3 1/4") around joints. For timber substructures, it should be ≥ 100.0 mm (approx. 3 1/4") around joints. Distance B should be \leq distance A (support/beam), but never greater than 600.0 mm (approx. 23 3/4").

Distance from Edge

When installing using screws, the distance from the edge should be 20.0 mm–100.0 mm (approx. 3/4" – 4").

Panel Joints and Forming Joints

To allow dimensional changes to occur without restriction, joints should be at least 8.0 mm (approx. 5/16") wide. Joints should be filled with a permanently flexible sealant. Place permanently flexible plastic tape under joints.

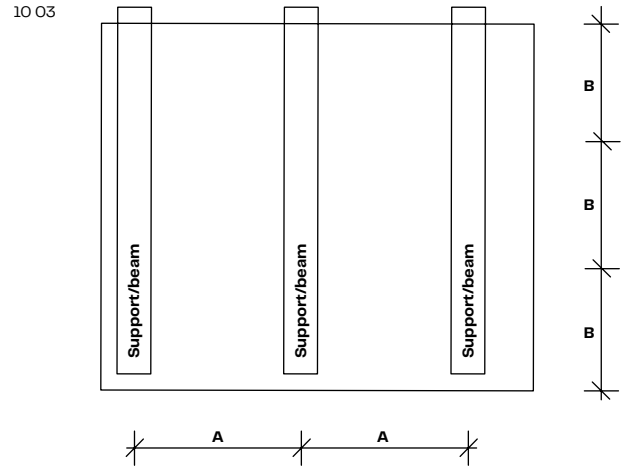

10 03 Substructure spacings

Live load (kN/m²)

max. permissible sag 1/300 kN/m ²	3.0	4.0	5.0
Panel thickness	Support distances in mm		
	A ≤ 500.0		
	Austria/Germany/Switzerland		
16.0 mm	X	X	X
18.0 mm	X	X	X
20.0 mm	X	X	X
	A ≤ 600.0		
	Austria/Germany/Switzerland		
16.0 mm	X	X	-
18.0 mm	X	X	X
20.0 mm	X	X	X
	A ≤ 800.0		
	Austria/Switzerland		
20.0 mm	X	X	-

x = permissible
For applications that are necessary for approval in Germany, maximum spacing of beams in accordance with general building regulation approval Z-50.4-377 should be observed. Find current approvals at www.fundermax.com.



Installing Podio Balcony Floor Panels— Invisible Mechanical Fastening

10 04

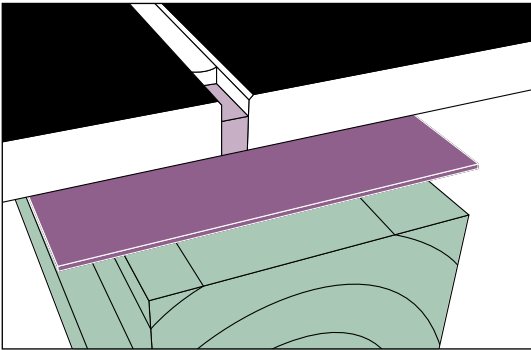

Fixed Point

Fixed points serve to evenly distribute (halve) changes in size. The drill hole diameter in Max Compact Exterior panels should be one channel depth smaller than the diameter of the screw.

Sliding Point

Based on the expansion clearance required, the diameter of the drill hole in the substructure should be larger than the diameter of the fasteners. Shaft diameter of the fastener plus 2 mm per meter of cladding material starting from the fixed point. Attach fasteners so the panel can move. Do not screw them in too tight. Do not use countersunk screws. The center of the hole in the substructure must match the center of the hole in the panels. Use a centering aid (drilling jig). Start fastening the panels at the center of the panel and work outward.

Notes

For timber substructures, please take note of the need for construction-related or chemical timber protection. Use an EPDM strip with a thickness of at least 1.2 mm.

For flawlessly sealed joints, using expansion joint filler is recommended.

10 05

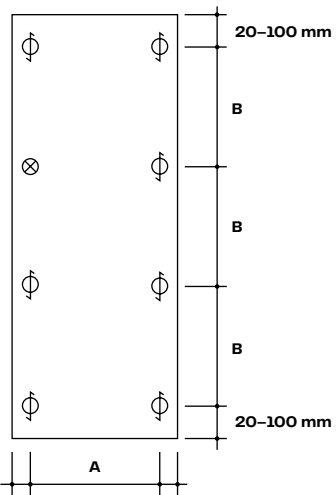

10 06

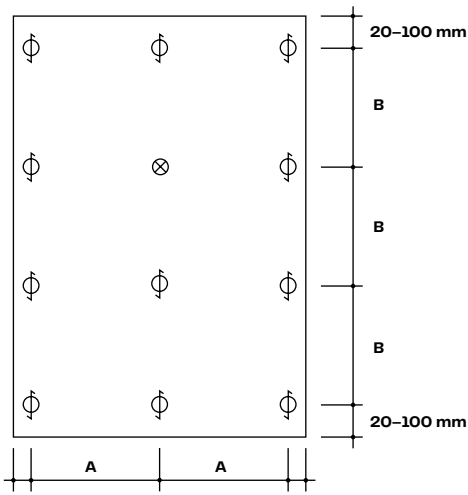

- ⊗ Fixed point
- ⊕ Sliding point
- A Support spacing
- B Fastener spacing

10 07



10 08



- 10 04 Balcony floor and wooden block
- 10 05 Single span panel
- 10 06 Double span panel
- 10 07 Balcony floor panel on wooden block with invisible fastening using Rampa sleeves (screwed)
- 10 08 Balcony floor panel on steel beams with invisible fastening using Rampa sleeves (screwed)

Installing Podio Balcony Floor Panels Using an Adhesive System

10 09

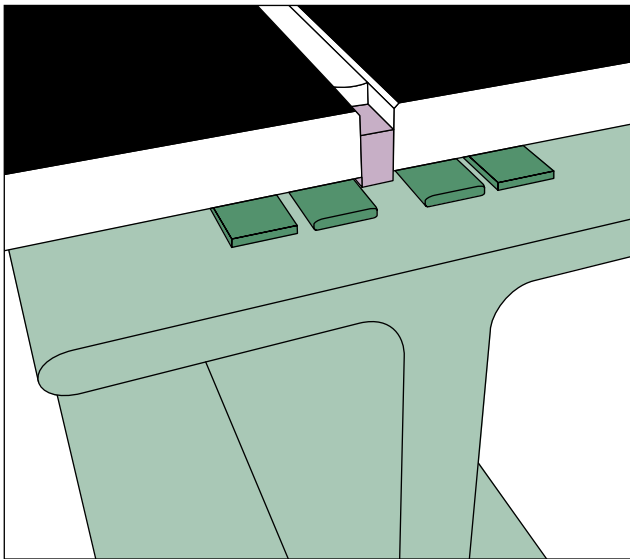

Gluing

Alternative to mechanical fastening: Gluing using specially designed adhesive systems from Pro Part or Innotec. These work on standard metal substructures.

Notes

Ensure fastening is unrestricted. Take into account the expansion and shrinkage behavior of Max Compact Exterior panels.

Please consult adhesive manufacturer for all relevant installation and surface preparation instructions.

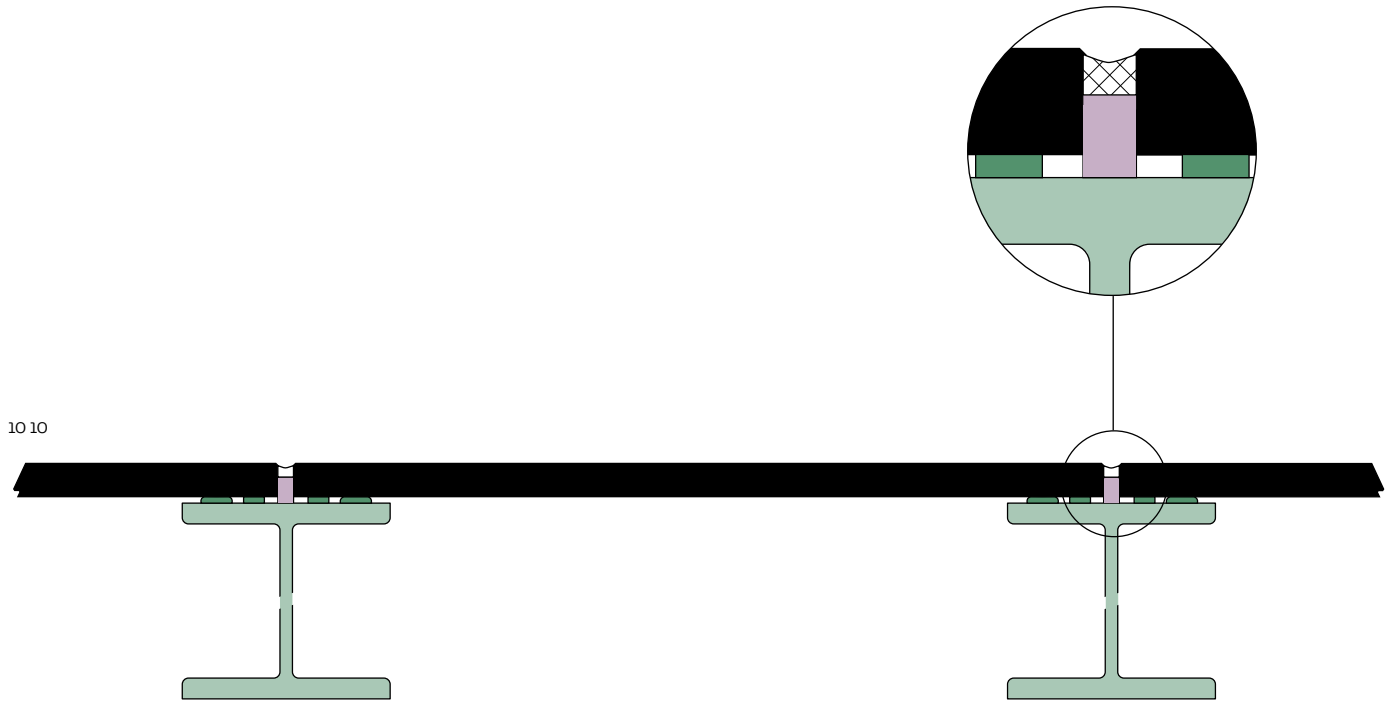

10 10

10 09 Balcony floor panel glued onto steel beams

10 10 Cross section of joints between balcony floor panels

11 Roof Coverings

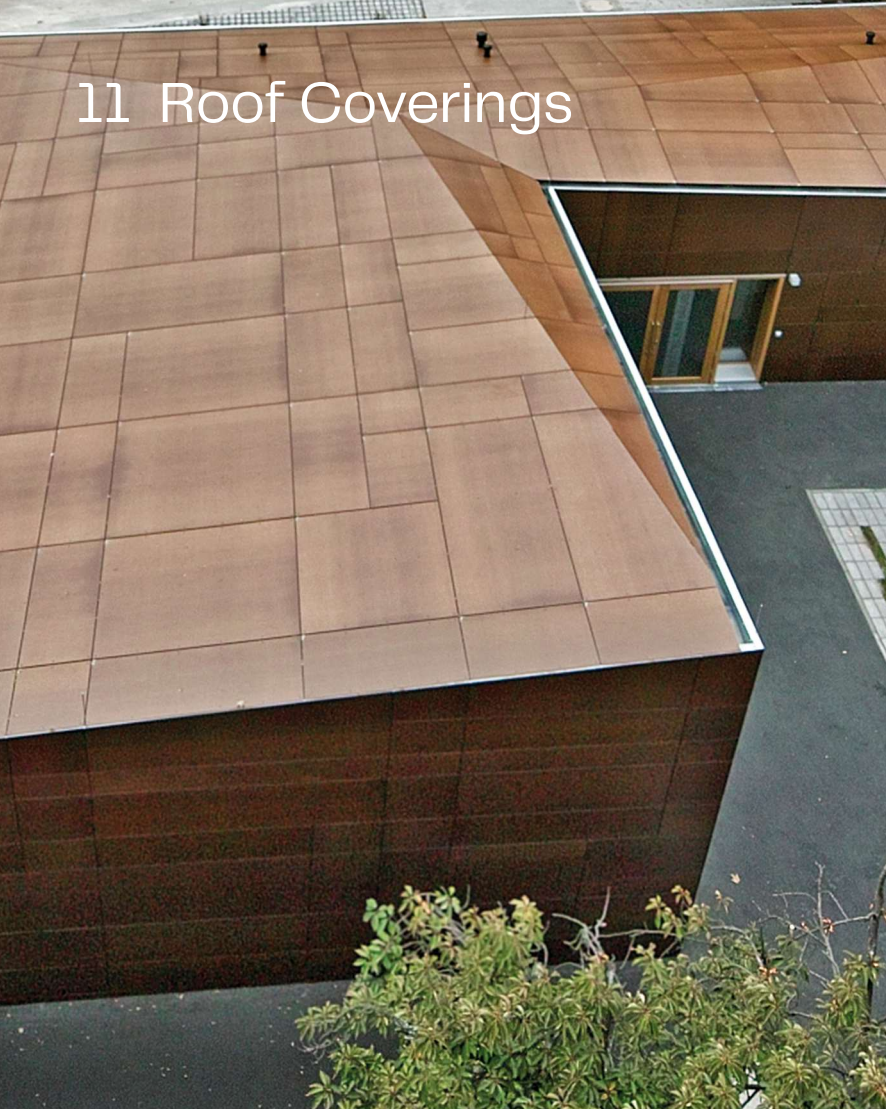

Fundermax





“The Max Compact Exterior panels helped us transform what was an uninviting, deteriorating masonry entryway of the school into a highly modern canopy that not only enhanced the exterior aesthetics but also allowed for natural daylighting to improve the interior environment.”

(Gian-Paul Piane., Sodus High School Project Architect)



General

A trend that is likely to gain ground in future is offering construction options that allow the use of a product both on the facade and as a roof covering. Design and planning should be carefully considered, especially in terms of detailed connections. Elements of the supporting structure, along with decorative panel materials, lend buildings character. By reducing the outer shell to essential visual areas, the observer's eye is drawn to shape and color. The advantages of a rainscreen facade also apply to roof coverings: design, technology, and cost-effectiveness.

Construction Design

Max Compact Exterior can be used for ventilated roof structures if the following requirement is taken into account: The roof pitch must be at least 6°.

Fire Requirements

Fire requirements must be complied with, taking into account regional building regulations, and determined on a project-by-project basis.

Max Exterior F Quality panels are Class A rated per ASTM E84.

Verification of Stability

Stability should be verified on a project-by-project basis for all applications on facades and roof coverings, taking into account regional building regulations.

Wind Load

Snow and wind loads should be taken into account for fasteners and spacing in the substructure.

Ventilation

The ventilation between the membrane and the covering (high degree of counterbattening) depends on the rafter length and roof pitch.

Membrane

The membrane should be installed as a seamless aquiferous layer for all roof pitches and construction options. Drainage occurs through the facade substructure.

Substructure

Depending on planning, the construction design consists of horizontal or vertical support frames and counterbattening attached to the supporting structure. Timber substructures cannot be used for roof applications.

Battens (Batten Profiles)

Vertical or horizontal metal support frames.
Single profiles as medium support and double profiles near joints (facilitates drainage).

Joints between Components

Manufacture skylights, air inlets and outlets, etc. with the appropriate sheet metal flashing.

Max Exterior minimum panel to panel joint or panel to any other material > 8mm

Panel Fastening

Attach roof cladding panels to support profiles using non-corrosive fasteners.
Determine fastener spacing based on the building concerned.

Fixed Point and Sliding Point

Attaching Max Compact Exterior panels to support frames requires sliding and fixed point installation.

Holes in Cladding Panels

Use a drill hole diameter of 6 mm for fixed points and 8.5 mm or as required for sliding points.
Centering tools must be used for fastener installation.

Holes in the Support Frame

Holes in the support frame should be positioned centrally in relation to the drill hole in the cladding material.

Fastening the Support Frames

Support frames are attached by means of suitable screws or rivets depending on the design of the counterbattening.

Staining

Avoid soiling caused during construction, higher roof surfaces, and separate drainage.

Details of Roof Construction with Max Compact Exterior Panels

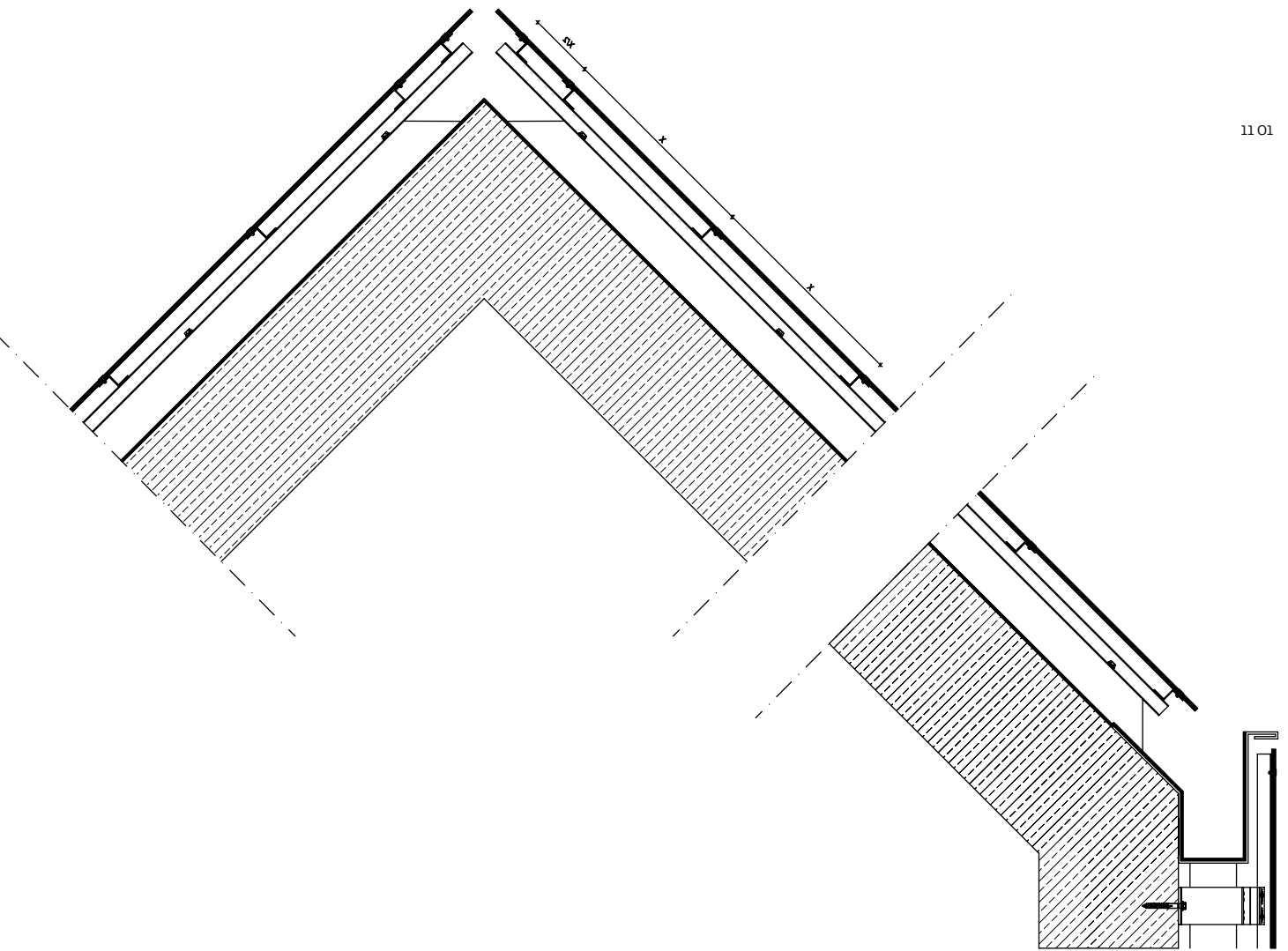

11 01

11 01 Vertical cross section: Ridge, roof construction

11 02 Vertical cross section: Roof construction

11 03 Vertical cross section: Verge

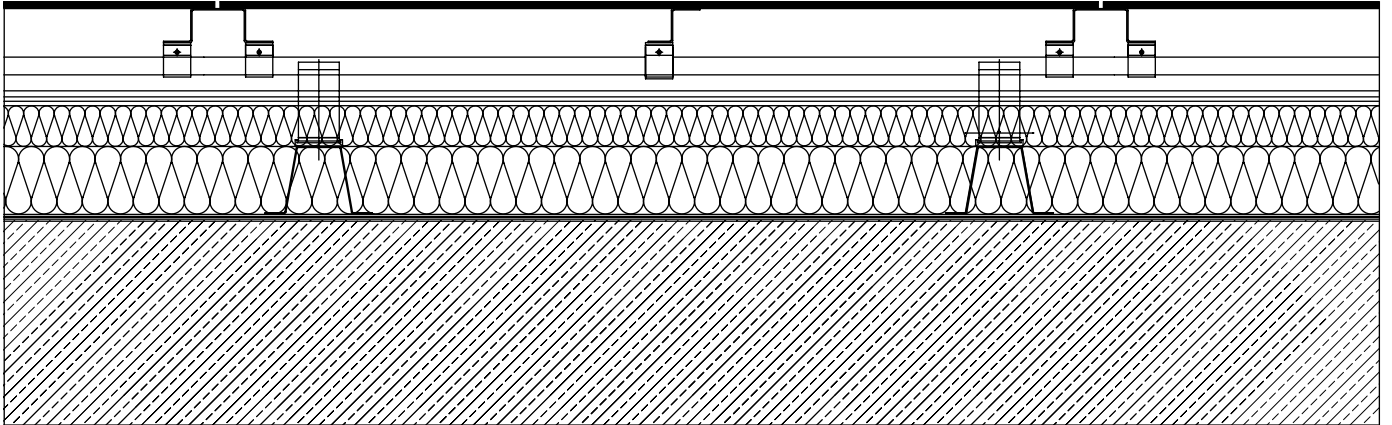

11 02

11 03

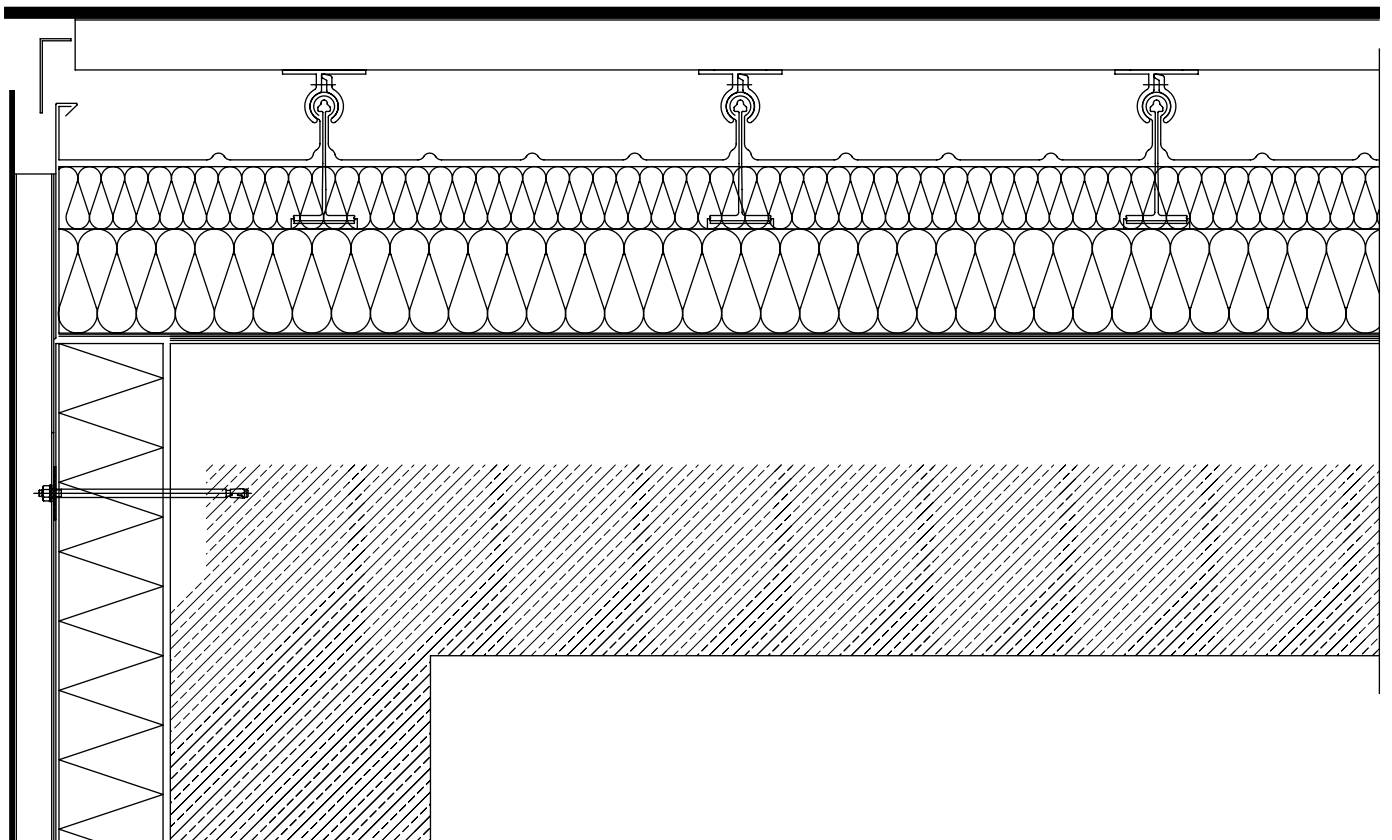

12 Sun Protection

“My dream house should throw everything else in the shade.”

(Bettina F., entrepreneur)



Exterior Fins with Max Exterior Panels

Parameters for design:

Thickness Max Exterior: 10mm, 13mm
Perforated Designs, Max Exterior 13mm

Sizes

Min Width: 4"

Max Length: 161 3/8"

Fasteners: Minimum 2 per clamp (by others)

Max Fastening distance from panel edges: 3 1/4"

Min. Fastening distance from panel edges: 3/4"

Must have fixed and floating points (Figures 156 & 157) Min. Expansion Joints: 1/4" (Figure 161 – on page 114)

Min. Joints Betweenpanels : 5/16"

One Fixed Point per panel, same diameter as fastener shaft. Balance of holes, oversized by 2mm/m as **Sliding Points**.



Exterior Fins with Max Exterior Panels

12" Maximum Panel Cantilever Past Clamp 48" OC Maximum Vertical Spacing of Clamps

Examples:

18" Deeps Fins

Minimum panel material inside clamp : 6"

Maximum panel cantilever past clamp : 12"

24" Fins

Minimum panel material inside clamp: 12"

Maximum panel cantilever past clamp: 12"

Panel clamps are typically custom fabricated by others. All details are custom, developed by others on a project specific basis, and must be approved by Fundermax Technical Department. All Engineering is by others and must be checked by the Project Engineer.

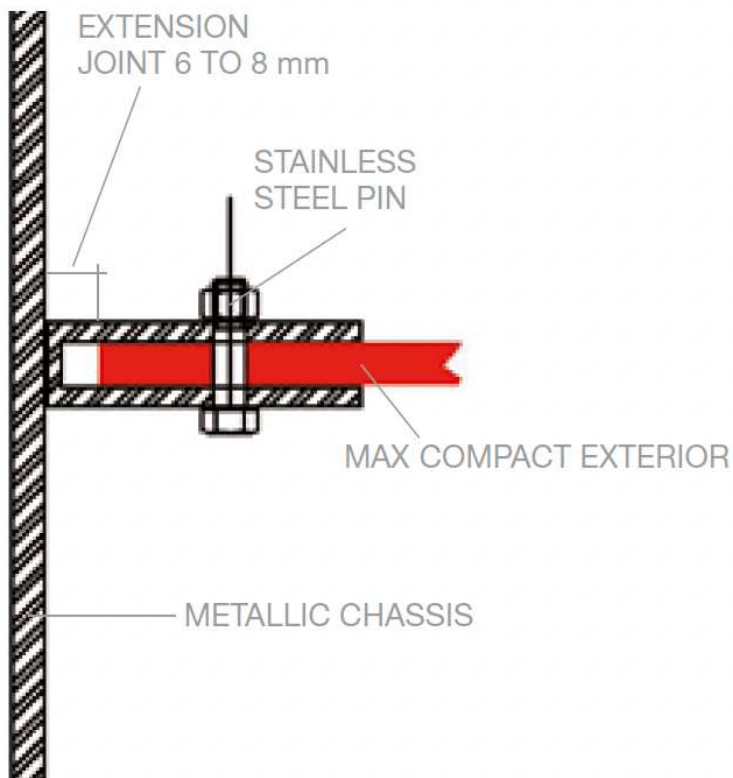

Fig. 161

Tubular Metal Frames may also be used with Face Fastened Fundermax panels on one or two sides.

Exterior Fins Project Examples



University of Canberra in Australia



CERI Office Building in the Netherlands



Casaideas Furniture Shopin Bolivia

13 Suppliers and Components

Touch Up Paint

Konig North America, LLC

2800 Black Lake Place, Unit D
Philadelphia, PA 19154
Phone: 215-426-6216 ext 312
Fax: 215-464-2144
brian@konigtouchup.com
www.konigtouchup.com

Fasteners

SFS Group USA, INC

1045 Spring Street
Wyomissing (USA) 19610
(610) 376-5751
<https://us.sfs.com/>

Subframing

NVelo

1045 Spring Street
Wyomissing (USA) 19610
(610) 376-5751
<https://us.sfs.com/nvelope>

EcoCladding

420 N. CEDROS AVE.
SUITE 103
SOLANA BEACH, CA 92075
888.730.8348
<https://www.ecocladding.com/contact>

Architectural Facade Systems Inc

2401 Worthington Drive, Suite 121
Denton TX 76207
(940) 323-2343
<https://www.afs-na.com/upp>

Monarch Metals

1700 Ocean Ave, Suite 2
Ronkonkoma NY 11779
(631) 868-5154
<https://www.monarchmetal.com/>

Knight Wall Systems

2401 East 6th Street
Deer Park WA 99006
1-855-KWS-WALL
<https://knightwallsystems.com/>

Allface Befestigungstechnologie GmbH

Ared Straße 29
2544 Leobersdorf
Austria
+43 2256 62518
<https://www.allface.com/>

Qvent

7631 E Greenway RD B2
Scottsdale, AZ 85260
<https://q-vent.com/>

Disclaimer

The information made available in this document is for general information purposes only. Not all of the systems mentioned and shown in this document are suitable or appropriate for all areas of application. All customers and third parties are obligated to inform themselves thoroughly about Fundermax products, including their suitability for certain purposes. Furthermore, we explicitly recommend that you and other users of this document seek out independent expert advice on compliance with local planning and use requirements, applicable laws, regulations, standards, guidelines, and testing standards.

Copyright

All texts, photos, diagrams, and audio and video files are subject to copyright and other laws protecting intellectual property and may not be duplicated, altered, or used on other websites for business purposes, etc.

Fundermax GmbH

Klagenfurter Straße 87-89, A-9300 St. Veit/Glan
T: +43 (0)5 9494-0
F: +43 (0)5 9494-4200
office@fundermax.at
www.fundermax.com

Fundermax Deutschland GmbH

Mundenheimer Weg 2
67117 Limburgerhof, Germany
infoGermany@fundermax.biz
www.fundermax.de

Fundermax France S.a.r.l.

3 Cours Albert Thomas
69003 Lyon, France
Tel: +33 (0)4 78682831
infoFrance@fundermax.biz
www.fundermax.fr

Fundermax India Pvt. Ltd.

Sy. No. 7, Honnenahalli, Doddballapur Road,
Yelahanka Hobli, Bangalore – 560064, India
officeIndia@fundermax.biz
www.fundermax.in

Fundermax Italia s.r.l.

Viale Venezia 22
33052 Cervignano del Friuli, Italy
infoItaly@fundermax.biz
www.fundermax.it

Fundermax Polska Sp. z o.o.

ul. Rybitwy 12
30-722 Kraków, Poland
Tel: +48 (0)12 6534528
infoPoland@fundermax.biz

Fundermax Swiss AG

Industriestrasse 38
5314 Kleindöttingen, Switzerland
Tel: +41 (0)56 2688311
infoSwiss@fundermax.biz
www.fundermax.ch

Fundermax Minimum Airflow Requirements

- 1) The free incoming and outgoing air gap must have a minimum of 50 cm²/m (3/8").
- 2) The air gap between panel and insulation or wall must have at all points a minimum of 20 mm (3/4").
- 3) Joints at corners and between panels, or panel to any other condition must be a minimum of 8 mm (5/16").
- 4) The installation of the panels must be done with one fixed point (nearest to the middle of the panel) and the balance of the holes must be sliding points.
- 5) Rivets and screws are set centered and straight in the drilling hole (Fig. 3).
- 6) Storage should be horizontal, with stable supports for panels.
- 7) If ventilation screens are used at the top and/or bottom of the cavity, they must be a minimum 40% perforation.

Please follow our **Max Compact Exterior Technical Details Brochure** at fundermax.us/brochures

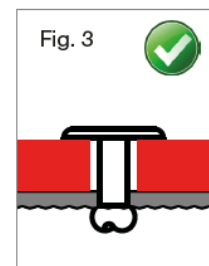
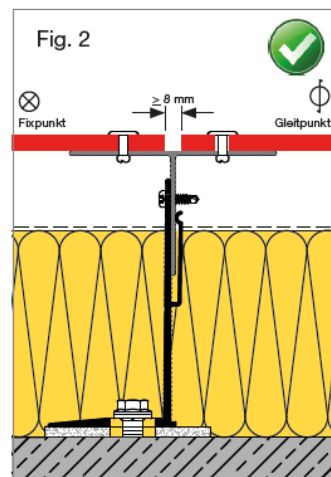
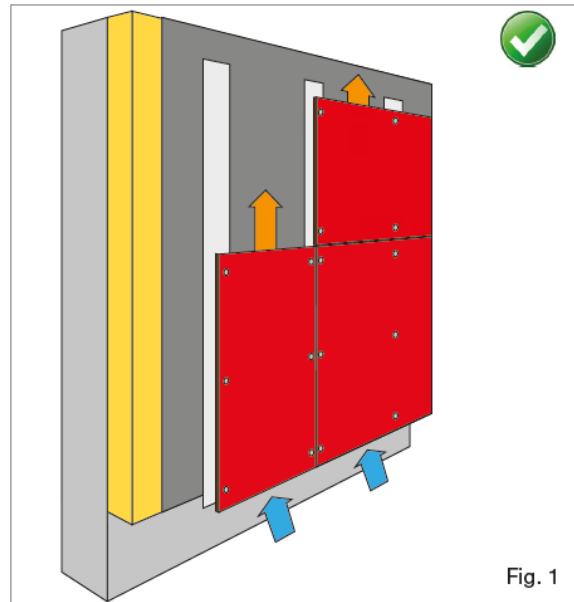

Fundermax North America, Inc.

9401-P Southern Pine Blvd.
 Charlotte, NC 28273, USA
 Tel: +1 (980) 299 0035
 Follow us: @fundermaxna
 contactfna@fundermax.biz
 www.fundermax.us



Order Exterior Samples